

BC SCHOOL SPORTS



2021-2022

HANDBOOK

PROPOSED POLICIES

100: GENERAL

DEFINITIONS

BC SCHOOL SPORTS – Throughout the Rules and Regulations, BC School Sports will be referred to as BCSS.

DATE OF TRANSFER – A transfer is deemed to have occurred on the date the student is physically present and taking courses at the receiving school.

ELIGIBILITY OFFICER – The Eligibility Officer is responsible for determination of student-athlete eligibility as defined in the BCSS policies and Rules and Regulations.

GRADE 8 ENTRY DATE - The date when a student-athlete enters grade eight (8) for the first time.

PLAYING DAY – A calendar day on which a member school team or student-athlete participates in competition of a BCSS activity, excluding playoffs, championships and fundraising or promotional games. Number of allowed playing days differs by sport, the number of allowable playing days is noted for each sport in (Section

PLAYOFF – Competition on the path to or at provincials following the conclusion of the regular season.

SCRIMMAGE – Any school or coach organized activity with student-athletes from multiple schools or teams present, participating in a BCSS activity against one another, under the guidance and/or supervision of coaches from their respective schools, where officials may or may not be present, or where a score may or may not be kept.

STARS – BC School Sports online student-athlete registration system.

STUDENT-ATHLETE – A student-athlete who is deemed eligible to compete for his/her school.

TIER - The threshold at which a BCSS member school will compete in each activity. The threshold is determined by grade 11 & 12 school populations as shown on the 1701 report from the Ministry of Education.

1701 MINISTRY OF EDUCATION REPORT - The report collects information about each school within the province for funding purposes, student movement, and enrollment trends. BCSS uses this report for school population purposes.

OPEN ACTIVITY – A BCSS activity that does not have a gender requirement to complete the team composition, the team may have any combination of student- athletes regardless of their gender identity.

CO-ED ACTIVITY – A BCSS official activity that has a gender requirement to complete the team composition, the team must have a specific number of student-athletes that identify as male and/or female to be eligible to compete.

BC SCHOOL SPORTS CHAMPIONSHIPS

BC School Sports has nineteen (19) active sport commissions within its organizational structure. The sport commissions of BC School Sports are responsible for organizing and conducting well qualifying events leading up to approved provincial championships as well as the sixty-five (65) approved provincial championships for the following sports:

AQUATICS	Boys	A, AA, AAA Team Championships	
	Girls	A, AA, AAA Team Championships	
BADMINTON	Coed	Combined Team Championships	
BASKETBALL	Boys	A, AA, AAA, AAAA Team Championships	
	Girls	A, AA, AAA, AAAA Team Championships	
CROSS COUNTRY	Junior	Boys	Team Championships
		Girls	Team Championships
	Senior	Boys	Team Championships
		Girls	Team Championships
CURLING	Boys	Team Championships	
	Girls	Team Championships	
FIELD HOCKEY	Girls	AA, AAA Team Championships	
FOOTBALL	Boys	AA, AAA Team Championships	
GOLF	Open	A, AA, AAA Open Team Championships	
GYMNASTICS	Coed	Boys and Girls Events Leading to a Combined Team Championship	
MOUNTAIN BIKING	Coed	Boys and Girls Events Leading to a Combined Team Championship	
RUGBY	Boys	AA, AAA, AAAA Team Championships	
SKIING	Boys	Team Championships	Combined Team Championships
	Girls	Team Championships	
SNOWBOARDING	Boys	Team Championships	Combined Team Championships
	Girls	Team Championships	
SOCCER	Boys	A, AA, AAA Team Championships	
	Girls	A, AA, AAA Team Championships	
TENNIS	Coed	AA, AAA Team Championships	
TRACK AND FIELD	Boys	AA, AAA Team Championships	Combined Team Championships
	Girls	AA, AAA Team Championships	
ULTIMATE	Coed	AA, AAA Team Championships	
VOLLEYBALL	Boys	A, AA, AAA Team Championships	
	Girls	A, AA, AAA, AAAA Team Championships	
WRESTLING	Boys	Weight Classes for Team Championship	Combined Team Championships
	Girls	Weight Classes for Team Championship	

200: CONSTITUTION & BYLAWS



CERTIFIED COPY
Of a document filed with the
Province of British Columbia
Registrar of Companies

A handwritten signature in black ink, appearing to read "Carol Prest".

CAROL PREST

CONSTITUTION

BC Society • Societies Act

NAME OF SOCIETY: **BC SCHOOL SPORTS**

Incorporation Number: S0009112
Business Number: 11880 1265 BC0001
Filed Date and Time: January 6, 2017 03:33 PM Pacific Time

The name of the Society is BC SCHOOL SPORTS

The purposes of the Society are:

The purpose of the Society shall be to provide leadership for and service to school sports in the Province of British Columbia by:

- (a) coordinating, advocating, promoting and protecting interschool athletics in and among Member Schools;
- (b) establishing, maintaining, and promoting among the Society's members, students, and others, an interest in athletics, physical recreation and sports;
- (c) fostering the growth and development of a coordinated athletic program in and between the schools of the province;
- (d) assisting in planning and coordinating interschool, interregional and provincial championship activities of Society members;
- (e) promoting the acquisition of athletic skills in the development of and appreciation of athletics through competition;
- (f) promoting fair play in all activities;
- (g) establishing and enforcing policies, rules and regulations for participants involved in interschool competition among Member Schools.



1. INTERPRETATION

1.1 Definitions

In these Bylaws and the Constitution of the Society, unless the context otherwise requires:

- (a) **“Act”** means the *Societies Act*, S.B.C. 2015, c. 18, as amended from time to time, and includes any successor legislation thereto;
- (b) **“Address of the Society”** means the address of the Society as filed from time to time with the Registrar;
- (c) **“Alter”** means amend, add to, delete or replace;
- (d) **“Appointing Entities”** means the following entities:
 - (i) BC Confederation of Parent Advisory Councils;
 - (ii) BC Principals and Vice Principals Association;
 - (iii) BC School Trustees’ Association;
 - (iv) BC School Superintendents’ Association;
 - (v) BC Teachers Federation;
 - (vi) Federation of Independent School Associations;
 - (vii) Indigenous Sport, Physical Activity and Recreation Council;
 - (viii) Ministry of Education; and
 - (ix) Ministry of Tourism, Arts, Culture & Sport;
- (e) **“Board”** means the Directors acting as authorized by Act, the Constitution and these Bylaws in managing or supervising the management of the affairs of the Society and exercising the powers of the Society;
- (f) **“Board Resolution”** means:
 - (i) a resolution passed by a simple majority of the votes cast in respect of the resolution by the Directors entitled to vote on such matter in person at a duly constituted meeting of the Board;
 - (ii) a resolution that has been submitted to all Directors and consented to in writing by 2/3 of the Directors who would have been entitled to vote on the resolution at a meeting of the Board, and a resolution so consented to is effective as though passed at a meeting of the Board;
- (g) **“Bylaws”** means the bylaws of the Society as filed with the Registrar;
- (h) **“Constitution”** means the constitution of the Society as filed with the Registrar;

- (i) **“Designated Representative”** of a Member School means the Person appointed in accordance section 2.12 to be the representative and contact for that Member School and to exercise the rights and obligations of membership on behalf of the Member School;
- (j) **“Directors”** means those Persons who are, or who subsequently become, directors in accordance with these Bylaws and have not ceased to be directors;
- (k) **“District Based Administrator”** means a Person who is the Superintendent, Assistant Superintendent, District Principal, Director of Instruction or other position with similar duties and responsibilities by whatever title they are known;
- (l) **“General Meeting”** means a meeting of the Members, and includes any annual general meeting and any special or extraordinary general meetings of the Society;
- (m) **“Income Tax Act”** means the *Income Tax Act*, R.S.C. 1985 (5th Supp.), c.1 as amended from time to time;
- (n) **“Legislative Assembly”** means the body of Legislative Assembly Members, assembled in a duly constituted General Meeting and acting as authorized by the Act and these Bylaws;
- (o) **“Local Athletic Association”** means an Organization (whether or not separately incorporated) usually of a single or small number of school districts, existing to coordinate local school sport competitions within a defined geographic boundary within the Province of British Columbia;
- (p) **“Members”** means those Persons and Schools that are, or that subsequently become, members of the Society in any class of membership in accordance with these Bylaws and that, in either case, have not ceased to be members of the Society;
- (q) **“Ministry of Education”** means the Ministry of Education of the Province of British Columbia, or its successor ministry;
- (r) **“Ordinary Resolution”** means:
 - (i) a resolution passed by a simple majority of the votes cast in respect of the resolution by those Members in good standing entitled to vote in person, at a duly constituted General Meeting; or
 - (ii) a resolution that has been submitted to the Members and consented to in writing by at least 2/3 of the voting Members who would have been entitled to vote on the resolution in person at a General Meeting,

and an Ordinary Resolution approved by any one or more of these methods is effective as though passed at a General Meeting of the Society;
- (s) **“Organization”** means an association, corporation or society;
- (t) **“Person”** means a natural person;
- (u) **“President”** means the Person elected to the office of president in accordance with these Bylaws;
- (v) **“Principal”** means a person who is the head administrator of a Member School by whatever title they are known;
- (w) **“Registered Address”** of a Member or Director means the address of that Person or Organization as recorded in the register of Members or the register of Directors;
- (x) **“Registrar”** means the Registrar of Companies of the Province of British Columbia;

- (y) **“School”** means:
 - (i) a school in British Columbia that is accredited by the Ministry of Education as an elementary-junior secondary school, elementary-secondary school, middle school, junior secondary school, senior secondary school, secondary school, distributed learning school, alternate school or independent school; or
 - (ii) a first nation school in British Columbia that is accredited by the government of Canada;
- (z) **“School Based Administrator”** means a Person who is the Principal, vice-principal, head administrator, assistant head administrator or other position with similar duties and responsibilities by whatever title they are known;
- (aa) **“Secretary”** means a Person elected to the office of secretary in accordance with these Bylaws;
- (bb) **“Society”** means “BC School Sports”;
- (cc) **“Special Resolution”** means:
 - (i) a resolution, of which the notice required by the Act and these Bylaws has been provided, passed by at least two-thirds (2/3) of the votes cast in respect of the resolution by those Members entitled to vote in person, at a duly constituted General Meeting; or
 - (ii) a resolution that has been submitted to the Members and consented to in writing by every Member that would have been entitled to vote on the resolution in Person at a General Meeting,

and a Special Resolution approved by any one or more of these methods is effective as though passed at a General Meeting;
- (dd) **“Treasurer”** means a Person elected to the office of treasurer in accordance with these Bylaws;
- (ee) **“Vice-President”** means a Person elected to the office of vice-chair in accordance with these Bylaws; and
- (ff) **“Zone”** or **“Designated Zone”** means those geographic regions set out in Schedule A, to facilitate representative structure for the Society, as amended from time to time by Ordinary Resolution.

1.2 Societies Act Definitions

Except as otherwise provided, the definitions in the Act on the date these Bylaws become effective apply to these Bylaws and the Constitution.

1.3 Plural and Singular Forms

In these Bylaws, a word defined in the plural form includes the singular and vice-versa.

1.4 Schedules

The schedules attached to these Bylaws do not form part of the Bylaws. Schedule A may be updated or altered by Board Resolution from time to time. Schedule B may be updated or altered by Ordinary Resolution from time to time.

2. MEMBERSHIP

2.1 Admission to Membership

Membership in the Society will be restricted to:

- (a) those Persons and Schools who transition as Members pursuant to Bylaw 2.14; and
- (b) those Persons and Schools who subsequently become Members in accordance with these Bylaws.

2.2 Classes of Membership

There will be one (1) class of voting membership, called the Legislative Assembly Members, and one (1) class of non-voting membership, called Member Schools.

2.3 Eligibility for Legislative Assembly Membership

Legislative Assembly membership is restricted to:

- (a) the Directors of the Society, in accordance with section 2.4;
- (b) the chair of certain committees, in accordance with section 2.5;
- (c) three (3) representatives appointed by each Zone, in accordance with section 2.6; and
- (d) one (1) representative appointed by each Appointing Entity, in accordance with section 2.7.

2.4 Directors are Legislative Assembly Members

Each Person who is a Director of the Society in accordance with these Bylaws, as amended from time to time, is automatically and without further action a Legislative Assembly Member, and will continue as a Legislative Assembly Member so long as that Person continues to be a Director.

2.5 Committee Chairs are Legislative Assembly Members

Each Person who is the chairperson of the:

- (a) Individual Sports Championships Committee;
- (b) Team Sports Championships Committee;
- (c) Fall Sports Rules Committee;
- (d) Winter Sports Rules Committee;
- (e) Spring Sports Rules Committee;
- (f) Eligibility Appeals Committee;
- (g) Competitive Fairness Committee; and
- (h) Sport Medicine and Athlete Safety Committee,

is automatically and without further action a Legislative Assembly Member, and will continue as a Legislative Assembly Member so long as that Person continues to be the chairperson of one of the above-listed committees.

2.6 Appointment by Zones

On or before June 30th of each calendar year each Zone may appoint three (3) Persons to be Legislative Assembly Members, including the following:

- (a) at least (1) School Based Administrator;
- (b) at least (1) Person who is male; and

(c) at least (1) Person who is female,

by delivering a notice of appointment in writing signed by an authorized signatory to the Address of the Society. Appointed Persons must be nineteen (19) years of age or older.

The Zone may appoint one (1) Person to be an alternate for each Legislative Assembly Member by delivering a notice of appointment in writing signed by an authorized signatory to the Address of the Society. The Persons appointed as alternate Legislative Assembly Members must have the same qualifications in paragraphs (a) to (c) as the Legislative Assembly Member for which they are serving as an alternate.

A Zone may revoke the appointment of a Legislative Assembly Member or an alternate Legislative Assembly Member it appointed by delivering a notice of revocation in writing signed by an authorized signatory to the Address of the Society.

2.7 Appointment by Appointing Entities

On or before June 30th of each calendar year each Appointing entity may appoint one (1) Person to be a Legislative Assembly Member and one (1) alternate appointee by delivering a notice of appointment in writing signed by an authorized signatory to the Address of the Society. Appointed Persons must be nineteen (19) years of age or older.

An Appointing Entity may revoke the appointment of a Legislative Assembly Member it appointed or their alternate by delivering a notice of revocation in writing signed by an authorized signatory to the Address of the Society.

2.8 Term of Appointed Legislative Assembly Members

The term of a Legislative Assembly Member appointed or their alternate in accordance with sections 2.6 and 2.7 will begin on August 1st of the year in which the Person is appointed and continue until July 31st of the next calendar year, unless he or she otherwise ceases to be a Legislative Assembly Member in accordance with these Bylaws. A Person may be appointed as a Legislative Assembly Member for consecutive terms without limit.

2.9 Eligibility for Member Schools

A School may be eligible to be accepted as a Member School if it:

- (a) meets the definition of a School as provided in paragraph 1.1(y); and
- (b) is a member in good standing of their Zone,

provided that the Board may, on application by a School, waive the requirements of paragraph (b) of this section if the School demonstrates a valid reason why it cannot be a member of the applicable Zone.

2.10 Application for Member Schools

A School may submit to the Society a written application, in such form as may be approved by the Society, to become a Member School.

An application for Member Schools must include:

- (a) all information required by the Society to process the application;
- (b) the name and contact information of a Person to be the Designated Representative of the School Member;
and
- (c) payment of applicable membership dues and fees.

2.11 Acceptance of Application for Membership

Following the receipt and review of its application, confirmation of eligibility and receipt of applicable membership dues or fees, the Board, or its designate, may accept a School as a Member School by entering the School into the register of Members.

The Board may, by Board Resolution postpone or refuse an application for membership for any reason which, in the Board's view, is necessary or prudent to protect the reputation and integrity of the Society.

2.12 Designation of Representative by Member School

A Member School may exercise the rights of membership through its Designated Representative, who will be the primary point of contact between the Society and the Member School. The Principal of a Member School will be the Designated Representative for that Member School, provided that the Principal may designate in writing another employee of the Member School as Designated Representative.

A Member School may have only one Designated Representative at a time and may change its Designated Representative by providing notice in writing to the Address of the Society.

2.13 Membership not Transferable

Membership is not transferable by a Member.

2.14 Transition of Membership

On the date these Bylaws come into force:

- (a) each School that is a member of the Society in good standing (as determined in accordance with these Bylaws) and who is eligible for membership under these Bylaws will continue as a Member in the appropriate class until ceasing in accordance with these Bylaws; and
- (b) each School that is not a member of the Society in good standing (as determined in accordance with these Bylaws) or who is not eligible for membership under these Bylaws will be deemed to have resigned from membership effective that date.

2.15 Cessation of Membership

A Person or School will immediately cease to be a Member:

- (a) in the case of a Legislative Assembly Member who is either a Director, in accordance with section 2.4, or the chairperson of a Policy Committee, in accordance with section 2.5, on the date he or she ceases to be a Director or chairperson of a Policy Committee, as the case may be;
- (b) in the case of a Legislative Assembly Member appointed in accordance with sections 2.6 or 2.7:
 - (i) upon the date such Member's nomination is revoked by the members' Zone or Appointing Entity; or
 - (ii) upon the expiry of his or her term;
- (c) in the case of a Member School, upon ceasing to be a School, or ceasing to be otherwise eligible for membership in accordance with section 2.9; or
- (d) in the case of any Member:

- (i) upon the date which is the later of the date of delivering his, her or its resignation in writing to the Secretary or to the Address of the Society and the effective date of the resignation stated thereon;
- (ii) upon the date which is sixty (60) days from the date on which such Member ceases to be in good standing for non-payment of an amount due and owing to the Society (if any);
- (iii) upon his, her or its expulsion; or
- (iv) upon his or her death, or in the case of an Organization, upon its dissolution.

3. MEMBERSHIP RIGHTS AND OBLIGATIONS

3.1 Rights of Membership

In addition to any rights conferred by the Act, a Member in good standing has the following rights and privileges of membership, by class:

Legislative Assembly Member:

- (a) to receive notice of, and to attend, all General Meetings;
- (b) to make or second motions at a General Meeting and to speak in debate on motions under consideration in accordance with such rules of order as may be adopted;
- (c) to exercise a vote on matters for determination at General Meetings; and
- (d) to nominate eligible Persons for election as a Director, in accordance with these Bylaws.

Member School:

- (e) to receive notice of, and to attend, all General Meetings;
- (f) to speak to motions under consideration in accordance with such rules of order as may be adopted;
- (g) Persons affiliated with a Member School may serve on committees of the Society, as invited;
- (h) may participate in the programs and initiatives of the Society, in accordance with such criteria as may be determined by the Board from time to time.

3.2 Member not in Good Standing

A Member that is not in good standing has the right to receive notice of, and to attend, all General Meetings, but is suspended from all of the other rights set out in section 3.1 for so long as he, she or it remains not in good standing.

3.3 Dues

All fees payable by Members to the Society, including annual fees and special levies and assessments, will be determined by the Board after considering the recommendations of the Legislative Assembly Members.

Annual membership fees are payable by every Member no later than fifteen (15) days after the fall team registration deadline each year. The Board may, by Board Resolution, make changes to the annual membership fees, which will take effect as determined by the Board.

3.4 Renewal and Reapplication of Member Schools

A Member School may renew its membership prior to its expiry by completing the renewal opt-in process and by paying applicable annual membership fees before the fall team registration deadline of each year, as outlined in the Society's policy.

A Member School whose membership has lapsed may reapply for membership after its expiry in accordance with section 2.10.

3.5 Standing of Members

All Members are deemed to be in good standing except:

- (a) a Member that has failed to pay such annual membership dues as are determined by the Board, if any, when due and owing and such Member is not in good standing so long as such amount remains unpaid; and
- (b) a Member that has been suspended by the Society.

3.6 Compliance with Constitution, Bylaws and Policies

Every Member will, at all times:

- (a) uphold the Constitution and comply with these Bylaws, the Regulations and the policies of the Society in effect from time to time;
- (b) abide by such codes of conduct and ethics adopted by the Society; and
- (c) further, the purposes, aims and objectives of the Society.

3.7 Suspension or Discipline of Members

A Member may be suspended or otherwise disciplined for breach of section 3.6 or for any conduct which the Board considers to be illegal, improper, unbecoming or likely to endanger the interests or reputation of the Society.

On receipt of a complaint, or of its own motion, the Board, or a committee thereof, may investigate, in accordance with such policies and procedures as the Board has established, the conduct of a Member with a view to determining whether discipline is appropriate. Where a Member is under investigation, the Board or its designate will promptly provide notice in writing to the Member of the nature of the investigation and the alleged wrongful conduct and provide the Member with an opportunity to submit a response, in writing or in person, as the Board or designate determines appropriate in the circumstances, prior to the close of the investigation.

Following an appropriate investigation, the Board or its delegate will issue a report of its findings and may suspend or otherwise discipline the Member under investigation, if discipline is determined to be warranted in the circumstances.

The Board may establish policies and procedures to administer and facilitate the process of Member discipline, provided that such policies and procedures are not contrary to the Act or these Bylaws.

3.8 Expulsion of Members

Following an appropriate investigation in accordance with section 3.7, a Member may be expelled by Board Resolution.

Notice of a Board Resolution to expel a Member will be accompanied by a brief statement of the reasons for the proposed expulsion and a copy of the notice will be provided to the Member in question.

The Member that is the subject of the proposed expulsion will be provided an opportunity to respond to the statement of reasons at or before the time the Board Resolution for expulsion is considered.

3.9 No Distribution of Income to Members

To operate without purpose of gain or profit to its members and any profits or other accretions to the Society shall be used in promoting its objects.

4. MEETINGS OF MEMBERS

4.1 Time and Place of General Meetings

The General Meetings of the Society will be held at such time and place, in accordance with the Act, as the Board decides.

4.2 Annual General Meeting

An annual general meeting will be held at least once every calendar year, in accordance with the Act.

4.3 Extraordinary General Meeting

Every General Meeting other than an annual general meeting is an extraordinary general meeting. The Board will normally call and hold an extraordinary general meeting to serve as an annual planning meeting at least once per year.

4.4 Calling of Extraordinary General Meeting

The Society will convene an extraordinary general meeting by providing notice in accordance with the Act and these Bylaws in any of the following circumstances:

- (a) at the call of the President;
- (b) when resolved by Board Resolution; or
- (c) when such a meeting is requisitioned by the Legislative Assembly Members in accordance with the Act.

4.5 Notice of General Meeting

The Society will provide notice of every General Meeting to each Member as follows:

- (a) by e-mail sent to the address provided by each Member who has provided the Society with an e-mail address not less than 21 days and not more than 60 days prior to the date of the General Meeting; and
- (b) by posting notice of the General Meeting on the Society's website for Members, for at least 21 days immediately prior to the date of the General Meeting.

If necessary in the Board's discretion, the Society may send notice of a General Meeting to one or more Members either personally, by delivery, courier or by mail posted to such Member's Registered Address, or, where the member has provided a fax number or e-mail address, by fax or e-mail, respectively.

4.6 Contents of Notice

Notice of a General Meeting will specify the place, the day and the time of the meeting and will include the text of every Special Resolution and Ordinary Resolution to be proposed or considered at that meeting.

4.7 Omission of Notice

The accidental omission to give notice of a General Meeting to a Member, or the non-receipt of notice by a Member, does not invalidate proceedings at that meeting.

5. PROCEEDINGS AT GENERAL MEETINGS

5.1 Business Required at Annual General Meeting

The following business is required to be conducted at each annual general meeting of the Society:

- (a) the adoption of an agenda;
- (b) the adoption of rules of order;
- (c) the approval of the minutes of the previous annual general meeting and any extraordinary general meetings held since the previous annual general meeting;
- (d) consideration of the report of the Directors;
- (e) consideration of the financial statements and the report of the auditor thereon, if any;
- (f) the consideration of any Members' proposals submitted in accordance with the Act;
- (g) the announcement of Directors.

The annual general meeting may include other business as determined by the Board in its discretion.

5.2 Attendance at General Meetings

Each Member, each Director and the Society's auditor, if any, are entitled to attend every General Meeting. In addition, the Board may also invite any other Person or Persons to attend a General Meeting as observers and guests. All observers and guests may only address the assembly at the invitation of the Person presiding as chairperson, or by Ordinary Resolution.

5.3 Electronic Participation in General Meetings

The Board may decide, in its discretion, to hold any General Meeting in whole or in part by Electronic Means.

When a General Meeting is to be conducted using Electronic Means, the Board must take reasonable steps to ensure that all participants are able to communicate and participate in the meeting adequately and, in particular, that remote participants are able to participate in a manner comparable to participants present in person, if any.

Persons participating by Electronic Means are deemed to be present at the General Meeting.

5.4 Quorum

Quorum for a General Meeting is one-third (1/3) of the total number of Legislative Assembly Members in good standing on the date of the General Meeting.

No business, other than the election of a Person to preside as chairperson at the meeting (if required) and the adjournment or termination of the meeting, will be conducted at a General Meeting at a time when a quorum is not present. If at any time during a General Meeting there ceases to be a quorum present, business then in progress will be suspended until there is a quorum present or until the meeting is adjourned or terminated.

5.5 Lack of Quorum

If within 30 minutes from the time appointed for a General Meeting a quorum is not present, the meeting, if convened on the requisition of Members, will be terminated, but in any other case it will stand adjourned to the next day, at the same time and

place, and if, at the adjourned meeting, a quorum is not present within 30 minutes from the time appointed for the meeting, the Legislative Assembly Members present will constitute a quorum and the meeting may proceed.

5.6 Chair of General Meeting

The President (or in the absence or inability of the President, the Vice-President) will, subject to a Board Resolution appointing another Person, preside as chairperson at all General Meetings; but if at any general meeting the President and Vice-President, or such alternate Person appointed by a Board Resolution (if any), is not present within 15 minutes after the time appointed for the meeting or requests that he or she not chair that meeting, the Directors present may appoint one of their number to preside as chairperson at that meeting. If the President and all other Directors present are unwilling to preside as chairperson, the Legislative Assembly Members present will chose one of their number to preside as chairperson.

5.7 Alternate Chair

If a Person presiding as chairperson of a General Meeting wishes to step down for all or part of that meeting, he or she may designate an alternate to chair such meeting or portion thereof, and upon such designated alternate receiving the consent of a majority of the Legislative Assembly Members present at such meeting, he or she may preside as chairperson.

5.8 Role of Chair

The Person presiding as chairperson of a General Meeting may not move or second a motion or resolution, but may speak in debate on, or answer questions related to, any motion or resolution without surrendering the chair.

5.9 Adjournment

A General Meeting may be adjourned from time to time and from place to place, but no business will be transacted at an adjourned meeting other than the business left unfinished at the meeting from which the adjournment took place.

5.10 Notice of Adjournment

It is not necessary to give notice of an adjournment or of the business to be transacted at an adjourned meeting except where a meeting is adjourned for more than fourteen (14) days, in which case notice of the adjourned meeting will be given as in the case of the original meeting.

5.11 Minutes of General Meetings

The Secretary or such other Person designated by the Board will ensure that minutes are taken for all General Meetings.

6. VOTING BY MEMBERS

6.1 Ordinary Resolution Sufficient

Unless the Act, these Bylaws or adopted rules of order provide otherwise, every issue for determination by a vote of the Members will be decided by an Ordinary Resolution.

6.2 Entitlement to Vote

Each Legislative Assembly Member in good standing is entitled to one (1) vote on matters for determination by the Members. No other Person or Organization is entitled to vote on a matter for determination by the Members, whether at a General Meeting or otherwise.

6.3 Voting Procedures

Voting by Legislative Assembly Members is limited to casting votes in person or by Electronic Means (where permitted) during a General Meeting.

Voting in person will be by show of hands or voting cards, except that, at the request of any five (5) Legislative Assembly Members present, a secret vote by written ballot will be required.

Voting by Electronic Means will be determined by the Board, provided that voting must occur at the same time as voting in person during a General Meeting in a way that only Legislative Assembly Members are able to cast votes.

6.4 Voting by Chair

If the Person presiding as chair of a General Meeting is a Legislative Assembly Member, then they may, in their sole discretion, cast a vote on any motion or resolution under consideration at the same time as voting occurs by all Legislative Assembly Members. A Person presiding as chair who is not a Legislative Assembly Member has no vote.

The Person presiding as chair of a General Meeting does not have a second or a casting vote in the event of a tie and a motion or resolution that is tied is defeated.

6.5 Voting by Proxy

If a Legislative Assembly Member appointed by a Zone in accordance with Bylaw 2.6 is unable to attend a General Meeting, the Person appointed as an alternate for that Legislative Assembly Member may attend the General Meeting in their place and may exercise the rights of membership on behalf of the Legislative Assembly Member.

Proxy voting is otherwise not permitted.

7. DIRECTORS

7.1 Management of Property and Affairs

The Board will have the authority and responsibility to manage, or supervise the management of, the property and the affairs of the Society.

7.2 Duties of Directors

Pursuant to the Act, every Director will:

- (a) act honestly and in good faith with a view to the best interests of the Society;
- (b) exercise the care, diligence and skill that a reasonably prudent individual would exercise in comparable circumstances;
- (c) act in accordance with Act and the regulations thereunder; and
- (d) subject to sections 7.2(a) to 7.2(c), act in accordance with these Bylaws.

Without limiting sections 7.2(a) to (d), a Director, when exercising the powers and performing the functions of a Director, must act with a view to the purposes of the Society.

7.3 Qualifications of Directors

Pursuant to the Act, a Person may not be nominated, elected or appointed to serve (or continue to serve) as a Director if he or she:

- (a) is less than 19 years of age;
- (b) has been found by any court, in Canada or elsewhere, to be incapable of managing his or her own affairs;
- (c) is an undischarged bankrupt; or
- (d) has been convicted of a prescribed offence within the prescribed period, for which no pardon has been granted, all in accordance with the Act.

In addition to the foregoing, a Person may not be nominated, elected or appointed to serve (or continue to serve) as a Director unless he or she:

- (e) is an athletic director or School Based Administrator of a Member School; or
- (f) is a district administrator or district athletic coordinator of a British Columbia school district; or
- (g) is a current or past president of a Zone or local association; and
- (h) is not suspended or on a significant leave of absence from his or her position in paragraphs (e) through 7.4(c)(i).

7.4 Composition of Board

The Board will be composed of up to nine (9) Directors, as follows:

- (a) the President;
- (b) the Vice-President or Past-President, whichever is currently holding office pursuant to Bylaw 9.7;
- (c) seven (7) Directors-at-large, including the following:
 - (i) at least one (1) representative from an A or AA School;
 - (ii) at least one (1) representative from an AAA or AAA School;
 - (iii) at least one (1) representative of a rural or semi-rural School, qualified in accordance with section 7.3;
 - (iv) at least one (1) representative of a School in either the Thompson-Okanagan Zone or the Vancouver Island Zone, qualified in accordance with section 7.3;
 - (v) at least one (1) representative of a School in either the Kootenay Zone, the North Central Zone or North West Zone, qualified in accordance with section 7.3; and
 - (vi) at least one (1) representative of a School in either the Vancouver Sea-to-Sky Zone, the Fraser North Zone, the South Fraser Zone or the Eastern Valley Zone, qualified in accordance with section 7.3.

As part of the above composition, at all times there must be at least two (2) female directors at least one (1) of whom must be a qualified representative holding a Director-at-large position pursuant to sub-paragraphs 7.4(c)(ii) to **Error! Reference source not found.**

Further, as part of the above composition, at all times there must be at least two (2) persons meeting the definition of a School Based Administrator or District Based Administrator. Whereas a District Based Administrator holds a Director-at-large position pursuant to **Error! Bookmark not defined.** 7.4(c)(i) or 7.4(c)(ii) the District the Director is an employee of must have at least one School in their District that meets the appropriate classification.

7.5 Invalidation of Acts

No act or proceeding of the Board is invalid by reason only of there being less than the required number of Directors in office.

7.6 Transition of Directors' Terms

Each Person who is a Director on the date these Bylaws become effective will continue as a Director for the term to which he or she was most recently elected.

Any previous terms served by Directors will be counted towards the term limits set out below.

7.7 Term of Directors-at-large

The term of office of Directors-at-large will normally be three (3) years. However, the Board may by Board Resolution determine that some or all vacant Director-at-large positions will have a term of less than three (3) years, the length of such term to be determined by the Directors in their discretion.

The term of office will commence fourteen (14) days after the date of the annual general meeting at which such Director-at-large was elected. If, however, the Director-at-large was elected other than at an annual general meeting his or her term of office will be deemed to have commenced fourteen (14) days after the next annual general meeting.

7.8 Consecutive Terms and Term Limits

Directors-at-large may be elected for up to two (2) consecutive full terms. A Person who has served six (6) consecutive years as a Director-at-large, by any combination of terms, may not be re-elected for at least one (1) year following the expiry of his or her latest term.

Notwithstanding the foregoing, if prior to the expiry of the second term of office of a Director-at-large, he or she is elected in accordance with these Bylaws to take office as the Vice-President, he or she may continue in office for the duration of his or her term as Vice-President, President and Past-President, or until he or she otherwise ceases to be a Director in accordance with these Bylaws.

7.9 Appointment to fill Vacancy

If a Director-at-Large ceases to hold office before the expiry of his or her term, the Board, by Board Resolution, may appoint a Person qualified in accordance with section 7.3 to fill the resulting vacancy.

The position occupied by an appointed replacement Director will become available for election at the next annual general meeting and each such appointed replacement Director will continue in office until the date that is fourteen (14) days after the next annual general meeting unless sooner ceasing to be a Director. The appointed replacement Director may run for the vacant position.

The period during which a Person serves as an appointed replacement Director does not count toward the term limits set out above.

7.10 Removal of Director

The Legislative Assembly Members may remove a Director before the expiration of such Director's term of office by Special Resolution and may elect a replacement Director by Ordinary Resolution to serve for the balance of the removed Director's term.

7.11 Ceasing to be a Director

A Person will immediately and automatically cease to be a Director:

- (a) upon the date which is the later of:
 - (i) the date of delivering his or her resignation in writing to the President or to the Address of the Society; and
 - (ii) the effective date of the resignation stated therein;
- (b) upon the expiry of his or her term, unless re-elected;
- (c) upon the date such Person is no longer qualified pursuant to section 7.3;
- (d) upon his or her removal; or
- (e) upon his or her death.

8. ELECTION OF DIRECTORS-AT-LARGE

8.1 Election of Directors-at-large

Directors-at-large will be elected by the Legislative Assembly Members at a General Meeting and will take office fourteen (14) days after the date of such meeting.

Elections for Directors-at-large may be conducted on a single ballot.

8.2 Election by Acclamation

In elections where the number of candidates is equal to or less than the number of vacant positions for Directors-at-large, the nominated candidates are deemed to be elected by acclamation, provided that if any two (2) Legislative Assembly Members so request, a vote will be required, to be conducted as determined appropriate by the Person presiding as chair of the meeting.

8.3 Election by Secret Ballot

In elections where there are more candidates than vacant positions for Directors-at-large, election will be by secret ballot with the name of each duly nominated candidate appearing individually on the ballot. Candidates will be deemed to be elected in order of those candidates receiving the most votes.

8.4 Voiding of Ballot

No Legislative Assembly Member will vote for more Directors-at-large than the number of vacant positions for Directors-at-large. Any ballot on which more names are voted for than there are vacant positions will be deemed to be void.

9. OFFICERS

9.1 Officers

The officers of the Society are the President, either the Vice-President or Past-President, the Secretary and the Treasurer, together with such other offices, if any, as the Board, in its discretion, may create. The President, Vice-President and Past-President are Directors by virtue of their election or succession to such office.

The Board may, by Board Resolution, create and remove such other offices of the Society as it deems necessary and determine the duties and responsibilities of all officers. Other officers need not be Directors.

9.2 Eligibility for Vice-President

A Person must serve at least one (1) term as a Director in order to be eligible for election as Vice-President.

9.3 Election of Vice-President

The Vice-President will be elected by the Legislative Assembly Members every two (2) years at the annual general meeting. The election of the Vice-President shall, in those years, be conducted prior to the election for Directors-at-large. Unsuccessful candidates for Vice-President (if any) may, if they wish and if qualified for available positions, be added to the ballot for as a Director-at-large.

In elections where there is only one candidate for election as Vice-President, that candidate is deemed to be elected by acclamation, provided that if any two (2) Legislative Assembly Members so request, a vote will be required, to be conducted as determined appropriate by the Person presiding as chair of the meeting.

In elections where there is more than one candidate for election as Vice-President, election will be by secret ballot with the name of each duly nominated candidate appearing individually on the ballot.

9.4 Term of Office of Vice-President

The term of office of the Vice-President will be one (1) year, commencing on the date that is fourteen (14) days after the annual general meeting at which he or she was elected, and continuing next Vice-President takes office approximately two (2) years later.

9.5 President

The Vice-President shall, if he or she consents, continue as President following the completion of his or her term as Vice-President.

The term of office of the President will be two (2) years, commencing on the date his or her term as Vice-President ends and continuing until a new President takes office approximately two (2) years later.

9.6 Past-President

The President shall, if he or she consents, continue as Past-President following the completion of his or her term as President.

The term of office of the Past-President will be one (1) year commencing on the date his or her term as President ends and continuing until anniversary of his or her taking office as Past-President.

9.7 Vice-President or Past-President

At any given time the officers of the Society will include either a Vice-President, or a Past-President, never both. During the year following an annual general meeting at which a Vice-President is elected, the officers will include a Vice-President and a President in the second year of his or her term. During the subsequent year, the officers will include a President in the first year of his or her term and a Past-President.

9.8 Appointment of Secretary and Treasurer

Each year at the first meeting of the Board following the annual general meeting the Board will appoint Persons to serve as the Secretary and the Treasurer. A Person need not be a Director in order to be appointed as Secretary or Treasurer.

9.9 Term of Office of Other Officers

The term of office for all other officers is two (2) years, commencing on the date the Director is appointed as an officer in accordance with these Bylaws and continuing until the first meeting of the Board held after the annual general meeting that is held two years later.

9.10 Consecutive Terms

Officers other than President, Vice-President and Past-President may be elected or appointed for consecutive terms. A Person who has served ten (10) consecutive years as any officer, by any combination of terms and in any offices, may not be re-elected or appointed for at least one (1) year following the expiry of his or her latest term.

9.11 Removal of Officers

A Person may be removed as an officer by Board Resolution.

9.12 Replacement

Should any officer for any reason be unable to complete his or her term, the Board will remove such officer from his or her office and will appoint a replacement without delay. In the case of the removal of the President, the Vice-President will, if willing, be appointed as President for the remainder of the vacant term, and any succeeding term. In the case of the removal of the Vice-President, the replacement appointed will hold office for the remainder of the vacant term, plus the succeeding terms as President and Past-President.

9.13 Duties of President

The President will supervise the other officers in the execution of their duties and will preside at all meetings of the Society and of the Board.

9.14 Duties of Vice-President

The Vice-President will assist the President in the performance of his or her duties and will perform those duties in the absence or inability of the President.

The Vice-President will perform such other duties as may be assigned by the Board.

9.15 Duties of Secretary

The Secretary will be responsible for making the necessary arrangements for:

- (a) the issuance of notices of meetings of the Society and the Board;
- (b) the keeping of minutes of all meetings of the Society and the Board;
- (c) the custody of all records and documents of the Society, except those required to be kept by the Treasurer;
- (d) the maintenance of the register of Member Schools; and

- (e) the conduct of the correspondence of the Society.

9.16 **Duties of Treasurer**

The Treasurer will be responsible for making the necessary arrangements for:

- (a) the keeping of such financial records, reports and returns, including books of account, as are necessary to comply with the Act and the *Income Tax Act*; and
- (b) the rendering of financial statements to the Directors, Member Schools and others, when required.

9.17 **Absence of Secretary at Meeting**

If the Secretary is absent from any General Meeting or meeting of the Board, the Directors present will appoint another Person to act as secretary at that meeting.

9.18 **Combination of Offices of Secretary and Treasurer**

The offices of Secretary and Treasurer may be held by one Person who will be known as the Secretary-Treasurer.

10. **POWERS AND RESPONSIBILITIES OF THE BOARD**

10.1 **Powers of Directors**

The Board may exercise all such powers and do all such acts and things as the Society may exercise and do, and which are not by these Bylaws or by statute or otherwise lawfully directed or required to be exercised or done by the Members in a General Meeting, but nevertheless subject to the provisions of:

- (a) all laws affecting the Society; and
- (b) these Bylaws and the Constitution.

Without limiting the generality of the foregoing, the Board will have the power to make expenditures, including grants, gifts and loans, whether or not secured or interest-bearing, in furtherance of the purposes of the Society. The Board will also have the power to enter into trust arrangements or contracts on behalf of the Society in furtherance of the purposes of the Society.

10.2 **Board Acts Valid**

No rule, decision or resolution of the Society invalidates a prior act of the Board that would have been valid if that rule, decision or resolution had not been made.

10.3 **Policies and Procedures**

The Legislative Assembly may establish such rules, regulations, policies and procedures relating to sport, fair play, athlete safety and competition as it deems expedient.

The Board may establish such rules, regulations, policies or procedures relating to all other aspects of the governance and operations of the Society as it deems expedient. Furthermore, the Board may establish rules, regulations, policies and procedures relating to sport, fair play, athlete safety and competition where there is either no policy in place, or where there is a significant risk to the Society. Rules, regulations, policies and procedures relating to sport, fair play, athlete safety or competition established by the Board will be in effect until the next General Meeting where they may either be ratified or defeated by the Legislative Assembly Members.

The Board may interpret and enforce the Society's rules, regulations, policies and procedures, including those established by the Legislative Assembly and those established by the Board.

No rule, regulation, policy or procedure is valid to the extent that it is inconsistent with the Act, the Constitution or these Bylaws.

10.4 Remuneration of Directors and Officers and Reimbursement of Expenses

Directors shall not be remunerated for serving in their capacity as a Director. Directors may be reimbursed for all expenses necessarily and reasonably incurred by him or her while engaged in the affairs of the Society, provided that all claims for reimbursement are in accordance with established policies.

10.5 Investment of Property and Standard of Care

If the Board is required to invest funds on behalf of the Society, the Board may invest the property of the Society in any form of property or security in which a prudent investor might invest. The standard of care required of the Directors is that they will exercise the care, skill, diligence and judgment that a prudent investor would exercise in making investments in light of the purposes and distribution requirements of the Society. The Board may establish further policies related to the investment of the Society's funds and property, provided that such policies are not contrary to the Act or these Bylaws.

10.6 Investment Advice

The Directors may obtain advice with respect to the investment of the property of the Society and may rely on such advice if a prudent investor would rely upon the advice in comparable circumstances.

10.7 Delegation of Investment Authority to Agent

The Directors may delegate to a stockbroker, investment dealer, or investment counsel the degree of authority with respect to the investment of the Society's property that a prudent investor might delegate in accordance with ordinary business practice.

11. PROCEEDINGS OF THE BOARD

11.1 Schedule and Place of Board Meetings

The Board will meet not less than twice each fiscal year, but may meet more often and may schedule meetings and otherwise regulate meetings of the Board as it sees fit.

Meetings of the Board may be held at any time and place determined by the Board, provided that notice is provided to every Director.

11.2 Calling of Meetings

The President may at any time call a meeting of the Board.

Any two (2) Directors may require a meeting of the Board be called as soon as possible by submitting a notice of meeting signed by two or more Directors to the Address of the Society.

11.3 Notice of Board Meetings

At least two (2) days' notice of a meeting of the Board will be sent to each Director. However, no formal notice will be necessary if all Directors were present at the preceding meeting when the time and place of the meeting was decided or are present at the meeting or waive notice thereof in writing or give a prior verbal waiver to the Secretary.

For the purposes of the first meeting of the Board held immediately following the election of a Director or Directors conducted at a General Meeting, or for the purposes of a meeting of the Board at which a Director is appointed to fill a vacancy in the Board, it is not necessary to give notice of the meeting to the newly elected or appointed Director or Directors for the meeting to be properly constituted.

11.4 Attendance at Board Meetings

Every Director is entitled to attend each meeting of the Board.

No other Person is entitled to attend meetings of the Board, but the Board may invite any Person or Persons to attend one or more meetings of the Board as advisors, observers or guests.

11.5 Quorum

Quorum for meetings of the Board will be a majority of the Directors currently in office.

11.6 Director Conflict of Interest

A Director who has a direct or indirect material interest in a contract or transaction (whether existing or proposed) with the Society, or a matter for consideration by the Directors:

- (a) will be counted in the quorum at a meeting of the Board at which the contract, transaction or matter is considered;
- (b) will disclose fully and promptly the nature and extent of his or her interest in the contract, transaction or matter;
- (c) is not entitled to vote on the contract, transaction or matter;
- (d) will absent him or herself from the meeting or portion thereof:
 - (i) at which the contract, transaction or matter is discussed, unless requested by the Board to remain to provide relevant information; and
 - (ii) in any case, during the vote on the contract, transaction or matter; and
- (e) refrain from any action intended to influence the discussion or vote.

The Board may establish further policies governing conflicts of interest of Directors and others, provided that such policies must not contradict the Act or these Bylaws.

11.7 Chair of Meetings

The President (or, in the absence or inability of the President, the Vice-President (if any)) will, subject to a Board Resolution appointing another Person, preside as chair at all meetings of the Board.

If at any meeting of the Board the President, the Vice-President and such alternate Person appointed by a Board Resolution, if any, are not present within 15 minutes after the time appointed for the meeting or requests that he or she not chair that meeting, the Directors present may choose one of their number to chair that meeting.

11.8 Alternate Chair

If the Person presiding as chair of a meeting of the Board wishes to step down as chair for all or part of that meeting, he or she may designate an alternate to chair such meeting or portion thereof, and upon such designated alternate receiving the consent of a majority of the Directors present at such meeting, he or she may preside as chair.

11.9 Role of Chair

The Person presiding as chair of a meeting of the Board may, if the Person is a Director, move, second and speak in debate on any motion or resolution at the meeting.

In the event of any doubt, dispute or ambiguity in relation to procedural matters or parliamentary process at a meeting of the Board, the person presiding as chair will have the authority to interpret and apply such rules of order as the meeting has adopted and determine matters in accordance with those rules, as well as the Act and these Bylaws.

11.10 Minutes of Board Meetings

The Secretary or such other Person designated by the Board will ensure that minutes are taken for all meetings of the Board.

12. DECISION MAKING AT BOARD MEETINGS

12.1 Passing Resolutions and Motions

Any issue at a meeting of the Board which is not required by the Act, these Bylaws or such rules of order as may apply to be decided by a resolution requiring more than a simple majority will be decided by Board Resolution.

12.2 Resolution in Writing

A Board Resolution may be in two or more counterparts which together will be deemed to constitute one resolution in writing. Such resolution will be filed with minutes of the proceedings of the Board and will be deemed to be passed on the date stated therein or, in the absence of such a date being stated, on the latest date stated on any counterpart.

12.3 Entitlement to Vote

Subject to section 11.6, each Director is entitled to one (1) vote on all matters at a meeting of Board. No other Person is entitled to a vote at a meeting of the Board.

12.4 Procedure for Voting

Except where expressly provided for in these Bylaws, voting on matters at a meeting of the Board may occur by any one or more of the following mechanisms, in the discretion of the chair:

- (a) by show of hands;
- (b) by written ballot; or
- (c) by roll-call vote or poll.

On the request of any one (1) or more Directors, a vote will be conducted by written ballot or other means whereby the tallied votes can be presented anonymously, in such a way that it is impossible for the assembly to discern how a given Director voted.

13. INDEMNIFICATION

13.1 Indemnification of Directors and Eligible Parties

To the extent permitted by the Act, each Director and eligible party (as defined by the Act) will be indemnified by the Society against all costs, charges and expenses, including legal and other fees, actually and reasonably incurred in connection with any legal proceeding or investigative action, whether current, threatened, pending or completed, to which that Person by reason of his or her holding or having held authority within the Society:

- (a) is or may be joined as a party to such legal proceeding or investigative action; or
- (b) is or may be liable for or in respect of a judgment, penalty or fine awarded or imposed in, or an amount paid in settlement of, such legal proceeding or investigative action.

13.2 Purchase of Insurance

The Society may purchase and maintain insurance for the benefit of any or all Directors, officers, employees or agents against personal liability incurred by any such Person as a Director, officer, employee or agent.

14. COMMITTEES

14.1 Creation and Delegation to Committees

The Legislative Assembly Members may create such standing policy committees as may from time to time be required by Ordinary Resolution. The Board may create such standing committees, special committees, working groups or task forces as may from time to time be required by Board Resolution. Any such committee will limit its activities to the purpose or purposes for which it is appointed and will have no powers except those specifically conferred by an Ordinary Resolution or Board Resolution, as the case may be.

The Board may delegate any, but not all, of its powers to committees which may be in whole or in part composed of Directors as it thinks fit.

14.2 Standing and Special Committees

Unless specifically designated as a standing committee, a committee is deemed to be a special committee and any special committee so created must be created for a specified time period only.

A special committee will automatically be dissolved upon the earlier of the following:

- (a) the completion of the specified time period; or
- (b) the completion of the task for which it was created.

A list of the current committees of the Society is appended as Schedule A to these Bylaws, which schedule may be amended by the Board to reflect changes to committees from time to time.

14.3 Terms of Reference and Rules

In the event the Legislative Assembly Members decide to create a committee, the Legislative Assembly Members must establish Terms of Reference for such committee. A committee, in the exercise of the powers delegated to it, will conform to any rules that may from time to time be imposed by the Legislative Assembly Members, in the Terms of Reference or otherwise, and will

report every act or thing done in the exercise of those powers at the next General Meeting held after it has been done, or at such time or times as the Legislative Assembly Members may determine.

In the event the Board decide to create a committee, the Board must establish Terms of Reference for such committee. A committee, in the exercise of the powers delegated to it, will conform to any rules that may from time to time be imposed by the Board in the Terms of Reference or otherwise, and will report every act or thing done in the exercise of those powers at the next Board meeting held after it has been done, or at such time or times as the Board may determine.

14.4 Meetings

The members of a committee may meet and adjourn as they think proper and meetings of the committees will be governed by the rules set out in these Bylaws governing proceedings of the Board, with such necessary changes having been made to ensure that the language makes sense in the context.

15. ZONES

15.1 General

There shall be nine (9) Zones that may choose whether or not to incorporate but must have written legislation governing its operations.

Zones will be comprised of the Schools, regardless of their Ministry of Education designation of public, independent or otherwise, that physically reside in the geographic boundaries of the Districts as listed below:

1. **Kootenay Zone;** school districts number 5, 6, 8, 10, 20 and 50.
2. **Thompson-Okanagan Zone;** school districts number 19, 22, 23, 53, 58, 67, 73, 74 and 83.
3. **North Central Zone;** school districts number 27, 28, 49, 57, 59, 60, 81 and 91.
4. **North West Zone;** school districts number 50, 52, 54, 82, 87, 92.
5. **Vancouver Island Zone;** school districts number 47, 61, 62, 63, 64, 68, 69, 70, 71, 72, 79, 84 and 85.
6. **Vancouver Sea-to-Sky Zone;** school districts number 39, 44, 45, 46 and 48.
7. **Fraser North Zone;** school districts number 40, 41, 42 and 43.
8. **South Fraser Zone;** school districts number 36, 37 and 38.
9. **Eastern Valley Zone;** school districts number 33, 34, 35, 75 and 78

Note: SD 93 (francophone) schools will belong to and compete in the zone that their school physically resides in.

15.2 Compliance with the Bylaws and Policies

Each Zone must comply with these Bylaws and the regulations and policies of the Society in effect from time to time. A Zone may create policies that are more restrictive than these Bylaws and the regulations and policies of the Society, however a Zone may not create or follow policies that are less restrictive than these Bylaws or the regulations and policies of the Society.

15.3 Zone President and Secretary

Each Zone must appoint a Person to act as Zone president and another Person to act as Zone secretary.

16. EXECUTION OF INSTRUMENTS

16.1 No Seal

The Society may have a corporate seal but will not use the seal for the purpose of executing documents.

16.2 Execution of Instruments

Contracts, documents or instruments in writing requiring the signature of the Society may be signed as follows:

- (a) for any contract, instrument or document relating to the receipt, payment or obligation for an amount greater than or equal to \$10,000, by any two (2) Directors, or by any one (1) Director and one (1) senior management employee; and
- (b) for contract, instrument or document relating to the receipt, payment or obligation for an amount less than \$10,000, by any two (2) employees, including at least one (1) management employee.

All contracts, documents and instruments in writing so signed will be binding upon the Society without any further authorization or formality.

The Board will have power from time to time by Board Resolution to appoint any officer or officers, or any Person or Persons, on behalf of the Society either to sign contracts, documents and instruments in writing generally or to sign specific contracts, documents or instruments in writing.

17. FINANCIAL MATTERS AND REPORTING

17.1 Fiscal Year

The fiscal year of the Society may be determined by the Board from time to time.

17.2 Accounting Records

The Society will maintain such financial and accounting records and books of account as are required by the Act and applicable laws.

17.3 Borrowing Powers

In order to carry out the purposes of the Society, the Board may, on behalf of and in the name of the Society, raise or secure the payment or repayment of money in any manner it decides, including the granting of guarantees, and in particular, but without limiting the foregoing, by the issue of debentures.

17.4 Restrictions on Borrowing Powers

The Legislative Assembly Members may by Ordinary Resolution restrict the borrowing powers of the Board.

17.5 When Audit Required

The Society is not required to be audited. However, the Society will conduct an audit or review of its annual financial statements if:

- (a) the Directors determine to conduct an audit or review engagement by Board Resolution; or
- (b) the Legislative Assembly Members require the appointment of an auditor by Ordinary Resolution,

in which case the Society will appoint an auditor qualified in accordance with, and will comply with all relevant provisions of, Part 9 of the Act and these Bylaws.

17.6 Appointment of Auditor at Annual General Meeting

If the Society determines to conduct an audit or review engagement, an auditor will be appointed at an annual general meeting, to hold office until such auditor is reappointed at a subsequent annual general meeting or a successor is appointed in accordance with the procedures set out in the Act or until the Society no longer wishes to appoint an auditor.

17.7 Vacancy in Auditor

Except as provided in section 17.8, the Board will fill any vacancy occurring in the office of auditor and an auditor so appointed will hold office until the next annual general meeting.

17.8 Removal of Auditor

An auditor may be removed and replaced by Ordinary Resolution in accordance with the procedures set out in the Act.

17.9 Notice of Appointment

An auditor will be promptly informed in writing of such appointment or removal.

17.10 Restrictions on Appointment

A Person who is not independent of the Society in accordance with section 113 of the Act must not be appointed or act as the auditor for the Society.

17.11 Auditor's Report

The auditor, if any, must prepare a report on the financial statements of the Society in accordance with the requirements of the Act and applicable law.

17.12 Participation in General Meetings

The auditor, if any, is entitled in respect of a General Meeting to:

- (a) receive every notice relating to the meeting to which a Member is entitled;
- (b) attend the meeting; and
- (c) to be heard at the meeting on any part of the business of the meeting that deals with the auditor's duties or function.

An auditor who is present at a General Meeting at which the financial statements are considered must answer questions concerning those financial statements, the auditor's report, if any, and any other matter relating to the auditor's duties or function.

18. NOTICE GENERALLY

18.1 Entitlement to Notice

Notices of a General Meeting will be given to:

- (a) every Legislative Assembly Member on the register of Members on the day the notice is given;

- (b) the Designated Representative for every Member School shown on the register of Members on the day the notice is given; and
- (c) the auditor, if any is appointed.

18.2 Method of Giving Notice

Except as otherwise provided in these Bylaws, a notice may be given to a Member either personally, by delivery, courier or by mail posted to such Member's Registered Address, or, where the Member has provided a fax number or electronic mail address, by fax or electronic mail, respectively.

18.3 When Notice Deemed to have been Received

A notice sent by mail will be deemed to have been given on the day following that on which the notice was posted. In proving that notice has been given, it is sufficient to prove the notice was properly addressed and put in a Canadian Government post office receptacle with adequate postage affixed, provided that if, between the time of posting and the deemed giving of the notice, a mail strike or other labour dispute which might reasonably be expected to delay the delivery of such notice by the mails occurs, then such notice will only be effective when actually received.

Any notice delivered personally, by delivery or courier, facsimile, or electronic mail will be deemed to have been given on the day it was so delivered or sent.

18.4 Days to be Counted in Notice

If a number of days' notice or a notice extending over any other period is required to be given, the day the notice is given or deemed to have been given and the day on which the event for which notice is given will not be counted in the number of days required.

19. MISCELLANEOUS

19.1 Dissolution

On the winding up or dissolution of the Society, the assets of the Society shall not be distributed among the Members or any of them, unless such recipient Member or Members are charitable institutions in existence solely for charitable purposes. After all debts have been paid, or provision for their payment has been made, the assets remaining shall be paid, transferred and delivered to one or more charitable institutions in existence solely for charitable purposes, which shall be chosen by resolution of the members of the Society, or failing such resolution, by resolution of the directors of the society.

19.2 Inspection of Documents and Records

The documents and records of the Society, including the financial and accounting records and the minutes of General Meetings, committee meetings and meetings of the Board, will be open to the inspection of any Director at reasonable times and on reasonable notice.

A Member in good standing is entitled, upon providing not less than fourteen (14) days' notice in writing to the Society, to examine any of the following documents and records of the Society at the Address of the Society during the Society's normal business hours:

- (a) the Constitution and these Bylaws, and any amendments thereto;
- (b) the statement of directors and registered office of the Society;

- (c) minutes of any General Meeting, including the text of each resolution passed at the meeting;
- (d) resolutions of the Members in writing, if any;
- (e) annual financial statements relating to a past fiscal year that have been received by the Members in a General Meeting;
- (f) the register of Directors;
- (g) the register of Members;
- (h) the Society's certificate of incorporation, and any other certificates, confirmations or records furnished to the Society by the Registrar;
- (i) copies of orders made by a court, tribunal or government body in respect of the Society;
- (j) the written consents of Directors to act as such and the written resignations of Directors; and
- (k) the disclosure of a Director regarding a conflict of interest.

Except as expressly provided by statute or at law, a Member will not be entitled or have the right to examine or inspect any other document or record of the Society. However, subject to such policies as the Board may establish, a Member in good standing may request, in writing delivered to the Address of the Society, to examine any other document or record of the Society and the Board may allow the Member to examine the document or a copy thereof, in whole or in part and subject to such redaction as the Board deems necessary, all in the Board's sole discretion.

Copies of documents which a Member is allowed to examine may be provided on request by such Person for a fee to be determined by the Board.

19.3 Right to become Member of other Society

The Society will have the right to subscribe to, become a member of, and cooperate with any other society, corporation or association whose purposes or objectives are in whole or in part similar to the Society's purposes.

20. BYLAWS

20.1 Entitlement of Members to copy of Constitution and Bylaws

On being admitted to membership, each Member is entitled to, and upon request the Society will provide him or her with, access to a copy of the Constitution and these Bylaws.

20.2 Special Resolution required to Alter Bylaws

These Bylaws will not be altered except by Special Resolution.

20.3 Effective Date of Alteration

Any alteration to the Bylaws or Constitution will take effect on the date the alteration application is filed with the Registrar in accordance with the Act.

300: MEMBERSHIP

310.0 MEMBERSHIP PROCESS

311.0 CRITERIA FOR MEMBERSHIP

As per BC School Sports Bylaw 2.2 {Classes of Membership}, BC School Sports has two (2) classes of membership:

- 311.1 School: A school in British Columbia that is accredited by the Ministry of Education as an elementary-junior secondary, elementary-secondary, middle school, junior secondary, senior secondary, distributed learning school, alternate school or non-public school in funding group classifications 1, 2 or 3, and includes full-time students in any or all of grades eight (8) through twelve (12), and fulfills the requirements of membership in BC School Sports.
- 311.2 Legislative Assembly Member; A representative elected or appointed through a process as approved in the BCSS Bylaws to act and vote on behalf of the BC School Sports Membership. Legislative Assembly Members are comprised of four groups: The Board of Directors, Chairs of the BCSS Policy Committees, Zone Representatives, and Partner Organizations.

320.0 SCHOOL MEMBERS

321.0 APPLICATION

- 321.1 Applications for new school membership are due no later than second Friday after Labor Day. Schools that fulfill the membership requirements must complete and submit a new member application. Upon approval schools will be invoiced directly for the annual membership fee.

322.0 MEMBER SCHOOL RENEWAL

The membership year will run from August 1 to July 31. Administrators at members schools that wish to renew their BC School Sports membership must complete the "renewal opt-in" in the BCSS STARS database, no later than the Fall Team Registration Deadline. Once BC School Sports receives the renewal opt-in, the member school will receive an invoice for annual membership fees.

323.0 EXPECTATIONS OF A MEMBER SCHOOL

Member schools of BCSS must comply with the rules as stipulated in the BCSS Constitution, Bylaws, and Policies relating to interscholastic programs. Failure to adhere to the above are grounds for discipline at the discretion of the Board of Directors. The rules shall not be waived by agreement or otherwise. All member schools are expected to:

- 323.1 Ensure that all school programs that are official BCSS activities, operate as such and operate under the jurisdiction of BCSS.
- 323.2 Ensure all BCSS official activities contribute towards the improvement of the health, fitness and general welfare of all individuals taking part in the program.
- 323.3 Ensure safety and welfare of students is a priority. Adequate protective equipment, safety precautions, and risk management policies are to be utilized for all practices and interscholastic competitions.
- 323.4 Be diligent in monitoring interscholastic competition, knowing that a member school may only participate against other BCSS member schools in official BCSS activities unless out of province sanctioning is approved or an exception is granted in writing by the Executive Director.
- 323.5 Ensure student-athletes are accompanied by a teacher-coach, teacher-sponsor, administrator or responsible adult approved by the administrator, and in accordance with the applicable school and/or school district policy in all official BCSS activities. The school administrator must ensure that the supervisor adheres to all BC School Sport policies, including the Coach's Code of Ethics as outlined in the BCSS handbook (Section 400). The school administrator should notify the competition coordinator of who the adult supervisor is, should that supervisor be different than the coach. The supervisor must be in attendance for the duration of the competition.
- 323.6 Be responsible for ensuring all coaches, including community coaches, have been properly vetted in accordance with school and/or district policy. Schools are responsible to ensure coaches are educated on BCSS policy, including but not limited to Codes of Ethics (Section 400) and Recruiting, Undue Influence (Section 430.0) and rules regarding the activity in question. It is also strongly recommended that the school ensures coaches are aware of emergency protocols, supervision requirements, competition schedule and deadlines, accountability for equipment, jurisdictional boundaries and any paper work that is needed prior to commencing coaching duties.
- 323.7 Ensure all members of a coaching staff (including but not limited to Head Coaches, Assistant Coaches, Coordinators, Teacher Sponsors, Student-Managers), must complete the Concussion Awareness Training Tool

(www.cattonline.com) and provide their certificate of completion to their Athletic Director prior to engaging in any duties with student-athletes in a practice or game setting.

323.7.1 Athletic Directors are not required to submit the certificates but must be able to produce them if requested by BCSS or the member school's zone.

323.7.2 BCSS will recognize the Concussion Awareness Training Tool Certificate of completion for a period of two (2) calendar years from the date of completion before having to be completed again.

323.8 Member schools should monitor their compliance with BCSS bylaws and policies. Schools are responsible to educate student-athletes, coaches, and other appropriate persons to ensure compliance.

323.9 Provide full disclosure of information in all BCSS matters. This includes verbal communication, documentation and an expectation that relevant information will not be omitted or altered. BCSS reserves the right to investigate and/or follow up to ensure the accuracy of information presented during any BCSS matter.

323.10 Maintain appropriate crowd control, as per the Spectator Code of Conduct (Section 400), at all interscholastic contests and events.

324.0 ROLE OF THE ADMINISTRATOR

The administrator of a member school shall be the representative of the member school and is responsible for all official BCSS activities in which the school partakes. The administrator is expected to:

324.1 Complete the annual Membership Renewal Process (opt-in) by the applicable deadline.

324.3 Ensure all member school expectations are upheld.

324.4 Appoint and support the school Athletic Directors with daily inter-scholastic athletic operations.

330.0 MEMBER SCHOOL CLASSIFICATIONS

BC School Sports will use the following school classifications for the purposes of governance and administration:

School population will be calculated as all enrolled students in Grades 8-12, including students designated as Secondary Ungraded (SU). Each BCSS Sport will use its own specific tiering as found in Section 667.0

- **Class A:** 1 – 165
- **Class AA:** 166-475
- **Class AAA:** 476-950
- **Class AAAA:** 951+

As per the BCSS Bylaws, for the purposes of governance and administration, BCSS will use the following definition to identify schools as Urban, Semi-Rural or Rural.

- **Urban:** School is in a municipal population of 30,000 or greater, or a population less than 30,000 but within 85km of the nearest school within a municipality of greater than 30,000 people
- **Semi-Rural:** School is in a municipal population of 15,000 – 29,999 and more than 85km from the nearest school within an urban municipality
- **Rural:** School is in a municipal population of fewer than 15,000 and more than 125km from the nearest school in an urban municipality.

340.0 FEE SCHEDULE

341.0 MEMBER FEES

Fees for member schools are charged on an annual basis. Schools receive invoices upon completion of the membership renewal process and payment is due within 15 days of invoice. The school populations will be calculated from the Ministry of Education Headcount Reports for the previous school year, which was submitted by each school to the Ministry of Education. This information is provided to BCSS directly from the Ministry of Education.

Included in the headcount are all full-time students in grades eight (8) through twelve (12), plus the ungraded students at the secondary level. Membership fees per school population category are:

2021-2022 Membership Fees						
Class	Category	School Population	Senior	Middle/Junior	DL	Alt
A	1	1-75	\$ 450.00	\$250.00	\$250.00	\$200.00
	2	76-165	\$625.00	\$300.00	\$300.00	\$250.00
AA	3	166-299	\$ 850.00	\$350.00	\$350.00	\$300.00
	4	300-475	\$1,200.00	\$400.00	\$400.00	\$350.00
AAA	5	476-675	\$1,650.00	\$450.00	\$450.00	\$400.00
	6	676-950	\$ 2,150.00	\$550.00	\$550.00	\$450.00
AAAA	7	951-1350	\$2,550.00	\$600.00	\$600.00	\$500.00
	8	1351+	\$2,850.00	\$650.00	\$650.00	\$550.00

342.0 SETTING MEMBERSHIP FEES

Member Fees are established by the BC School Sports Board of Directors in June, after the BC School Sports Annual General Meeting. An increase in membership fees of greater than 12% can only be made with the approval of the Legislative Assembly.

343.0 ADJUSTMENT OF MEMBER SCHOOL FEES

Significant changes to a school population due to an addition or deletion of a grade, or the re-designation of a school may be adjusted on an individual member school basis by the Executive Director at the request of the member school.

344.0 LEGAL CONTINGENCY FUND

The Board of Directors, consistent with their responsibility to set dues for the membership, will apply a legal fund surcharge ('Legal Levy') as required to maintain a Legal Contingency Fund specifically to handle the prevention or response to legal action taken against the organization. The target balance of this contingency is \$50,000. A levy in the amount greater than \$100.00 per school will require Legislative Assembly approval.

345.0 CIAAA ATHLETIC DIRECTOR MEMBERSHIP FEE

Member schools, except for those that are Distributed Learning or Alternate Schools, will pay a \$50.00 fee annually known as the CIAAA Athletic Director Membership Fee, which will provide CIAAA membership for the AD of record in STARS.

350.0 GENERAL MEMBERSHIP POLICIES

351.0 RESPONSE TO PROVINCIAL JOB ACTION

BCSS believes that student-athletes and their participation in extracurricular activities should be free from political interference; however, the reality is that the majority of teacher-coaches are members of the BCTF and are bound by their professional obligations. In the event of a province-wide strike or job action, the BCSS Board of Directors will make a determination on whether or not league competition and championship play will continue and communicate this decision in a timely fashion. Safety of athletes and competitive balance will be guiding factors in the decision. Superintendents, Sport Advisory Committees and other stakeholders will be consulted. If it is determined that the safety of student-athletes or the competitive integrity of league competition or championship play will be affected, the Board of Directors shall suspend all competition. Public school teams that continue to practice or play during this period of suspension will not be supported by BCSS.

352.0 MARKETING

352.1 BC School Sports will only entertain marketing partnerships and ventures if they are beneficial to the goals and objectives of the association. Such partnership or ventures could be in the form of cash, product or contract.

352.2 BC School Sports will not enter into any sponsorship agreement with a company that is directly involved in the manufacture, distribution or sales of any product related to alcohol or tobacco.

352.3 BC School Sports will consider industrial exclusivity as part of a marketing agreement.

353.0 COMMERCIAL LOGOS

A member school is permitted the use of a maximum of two (2) credit card size commercial logos on any team uniform. A school uniform consists of the top and bottom or clothing usually worn during competition.

360.0 ATHLETIC ASSOCIATIONS

361.0 LOCAL ATHLETIC ASSOCIATIONS

Local Athletic Associations play an integral role in interscholastic sport and are designed to facilitate local play within a school district or a collection of districts in close proximity. They should enhance the student-athlete experience and generally, they determine the teams competing at a zone level from their association.

BC School Sports recognizes the importance of local athletic associations and will formally affiliate Local Associations where the association has:

- 361.1 Stated purposes that are aligned with the purposes of BCSS;
- 361.2 Adopted the competitive policies of BCSS, for activities sanctioned by both BCSS and the local athletic association;
- 361.3 Required membership in BCSS for all local athletic association member schools;
- 361.4 Be recognized by the school district(s) located within the geographic boundaries of the local athletic association as the organizing body of school sports and athletics;
- 361.5 Have written documents governing the actions of the associations, including the designation of a committee responsible for discipline, with defined processes and procedures;
- 361.6 Have a President who is employed by a school district or a BCSS member school

362.0 SCOPE OF THE RESPONSIBILITY

Local athletic associations are responsible for the following:

- 362.1 Applying the Bylaws and policies of BCSS within its geographic region;
- 362.2 Organizing league competitions within its geographic region;
- 362.3 Supporting the objectives and activities of BCSS within its geographic region;
- 362.4 Promoting the purposes and values of BCSS within its geographic region

363.0 DISAFFILIATION

A local athletic association may be disaffiliated by the BCSS Board of Directors.

370.0 ZONES

371. As per the BCSS Bylaws, BCSS will have 9 zones. In addition to the responsibilities as stated in the Bylaws, zones will

- Appoint 3 persons (and 3 alternates) to the Legislative Assembly, in accordance with the Bylaws
- Create and follow rules and regulations for zone procedures and determinations
- Coordinate Zone Championships for qualifying teams and individuals to BCSS Provincial Championships
- Represent the voices of the schools in the zone, and bring forth motions when appropriate
- Appoint the Zone Representatives to each of the Sport Advisory Committee's

380.0 BCSS CALENDAR

The BCSS activity calendar run Monday to Sunday and will begin with the Civic Day Holiday each August as found in Appendix 1

390.0 DISCIPLINARY JURISDICTION

BC School Sports, as the governing body for secondary school sport in British Columbia has the jurisdiction over disciplinary matters as stated in the BC School Sports Bylaws and Policies

- 390.1** Any disciplinary action taken by a member school, BC School Sports, or a recognized athletic association, against a participant will be recognized by all member schools and athletic associations. This includes membership-wide

adherence to any disciplinary action taken involving a probationary period, a suspension or a warning.

- 390.2** The disciplinary jurisdiction of BC School Sports is limited to the disciplined student-athlete, coach, or spectator's current, continued or future participation or involvement in activities, programs or services of BC School Sports.
- 390.3** Disciplinary action taken by a member school against its students, coaches, volunteers and/or any other participant, including spectators, that is over and above any disciplinary action taken by BC School Sports will be recognized by BC School Sports and all local associations.

400: CODE OF ETHICS & DISCIPLINE

410.0 CODES OF ETHICS

BC School Sports is committed to a safe and positive environment within its programs, activities and events, by making all individuals aware that there is at all times an expectation of appropriate behavior that is consistent with the values of BC School Sports.

411.0 ATHLETE CODE OF ETHICS

BC School Sports, school districts and your school consider it to be a privilege to represent your school in an athletic competition. Therefore, certain behavioral expectations come with this selection. Student-athletes are expected to uphold the following standards:

- 411.1 Treat all participants fairly regardless of gender, race, sexual orientation, religion, physical or mental abilities, political belief or economic status.
- 411.2 Embrace the highest ideals of sportsmanship, ethical conduct and fair play. Be modest in victory and gracious in defeat.
- 411.3 Show respect and give courtesy to opponents, officials, volunteers, teammates, spectators and coaches at all times.
- 411.4 Uphold the rules of the sport, spirit of such rules and encourage other athletes to do the same.
- 411.5 Represent yourself, your parents, your school and your community with proper conduct at all times on or off the playing field.
- 411.6 Respect other athletes' dignity and acknowledge that verbal or physical behaviour that constitutes harassment or abuse are unacceptable.
- 411.7 Participate in a manner that ensures the safety of fans, athletes, coaches and officials.
- 411.8 Accept decisions of officials without dispute.
- 411.9 Shall not use the media, social media or networking forums to criticize or threaten other student-athletes, coaches, officials, school teams, spectators or BCSS.
- 411.10 Demonstrate that it is a privilege to represent your school.

412.0 COACHES CODE OF ETHICS

The coach/student-athlete relationship is a privileged one. Coaches play a critical role in the personal and athletic development of student-athletes. Therefore, coaches are expected to model the fundamentally positive aspects of school sport. Coaches, including community coaches, are expected to uphold the following standards:

- 412.1 Recognize that school sport is an extension of the classroom, and shall conduct themselves accordingly when performing coaching duties;
- 412.2 Observe the Bylaws and Policies of BCSS and those of their local athletic association;
- 412.3 Observe the rules of the sport, the spirit of the rules of the sport, and shall encourage student-athletes to do the same;
- 412.4 Fulfill all competition, invitational, playoff and championship competitive and event obligations;
- 412.5 Treat all participants fairly regardless of gender, race, sexual orientation, religion, physical or mental abilities, political belief or economic status.

- 412.6 Respect the rulings of officials without gesture or argument, and shall require student-athletes to do the same;
- 412.7 Shall not use foul, profane, harassing or offensive language or gestures in the conduct of coaching duties;
- 412.8 Shall not use the media, social media or networking forums to criticize or threaten student-athletes, coaches, officials, school teams, spectators or BCSS.
- 412.9 Shall not use physical force of any kind in the conduct of coaching duties;
- 412.10 Shall not, under any circumstances, endorse, recommend, or suggest the use of performance-enhancing drugs or supplements by any student-athlete;
- 412.11 Shall not use tobacco products and alcohol while in the presence of student-athletes, and shall discourage their use by student-athletes;
- 412.12 Shall not, under any circumstances, require, suggest or imply that a student-athlete must be involved in any summer program or club program as part of their responsibilities as a school team member;
- 412.13 Shall not, under any circumstances, require, suggest or imply that a student-athlete cannot or should not participate in any BCSS-approved sport in the season preceding or following the coach's season of play; and
- 412.14 Shall not, under any circumstances, start pre-season tryouts or practices to the detriment of any in-season sport.

413.0 SPECTATORS CODE OF ETHICS

BC School Sports is committed to ensuring that all student-athletes, coaches and other individuals involved in BCSS activities have the opportunity to participate in a safe and enjoyable environment. Attendance at any BCSS event entitles you to enjoy an exhibition of skills developed by athletes in an educational setting. Spectators are expected to conduct themselves in a manner which supports the values of BC School Sports, and encourages the development of all student-athletes. Spectators are expected to uphold the following standards:

- 413.1 Show respect to all individuals including, student-athletes, coaches, officials, volunteers and fellow spectators.
- 413.2 Shall not use foul, profane, harassing or offensive language or gestures while in attendance at any BCSS event.
- 413.3 Abstain from consuming any unlicensed alcohol or illegal substances during any BCSS events.
- 413.4 Remain in designated spectators zones at event locations.
- 413.5 Shall not use the media, social media or networking forums to criticize or threaten student-athletes, coaches, officials, school teams, other spectators or BCSS.

414.0 PROCEDURE FOR COMPLAINTS REGARDING CODE OF ETHICS

- 414.1 Anyone may submit a Code of Ethics complaint to BCSS within 90 days of the incident occurring
- 414.2 All complaints alleging a violation of the Code of Ethics must be submitted in written form via the Code of Ethics Complaint form found on the BCSS website.
- 414.3 As per section 415.0, all complaints alleging a violation of the Code of Ethics by a coach, athlete or spectator shall be submitted to BCSS.
- 414.4 If the alleged violation has occurred in any event prior to Zone Championships, the complaint will be entrusted to the local association for any necessary investigation or action.
- 414.5 At any point during the process if a local association does not have the resources to appropriately deal with the matter, they may request BCSS to assist or take over the investigation.
- 414.6 If the alleged violation has occurred in any event during Zone or Provincial Championships, the complaint will be processed by BCSS.
- 414.7 There is no appeal of a decision of a local athletic association or BCSS.

414.8 Both BCSS and the respective local association are required to report any findings and rulings to one another after the investigation is concluded.

414.9 BCSS reserves the right to disclose Code of Ethics disciplines to any respective provincial sport organization.

415.0 CHANNELS OF COMMUNICATION FOR CODE OF ETHICS COMPLAINT

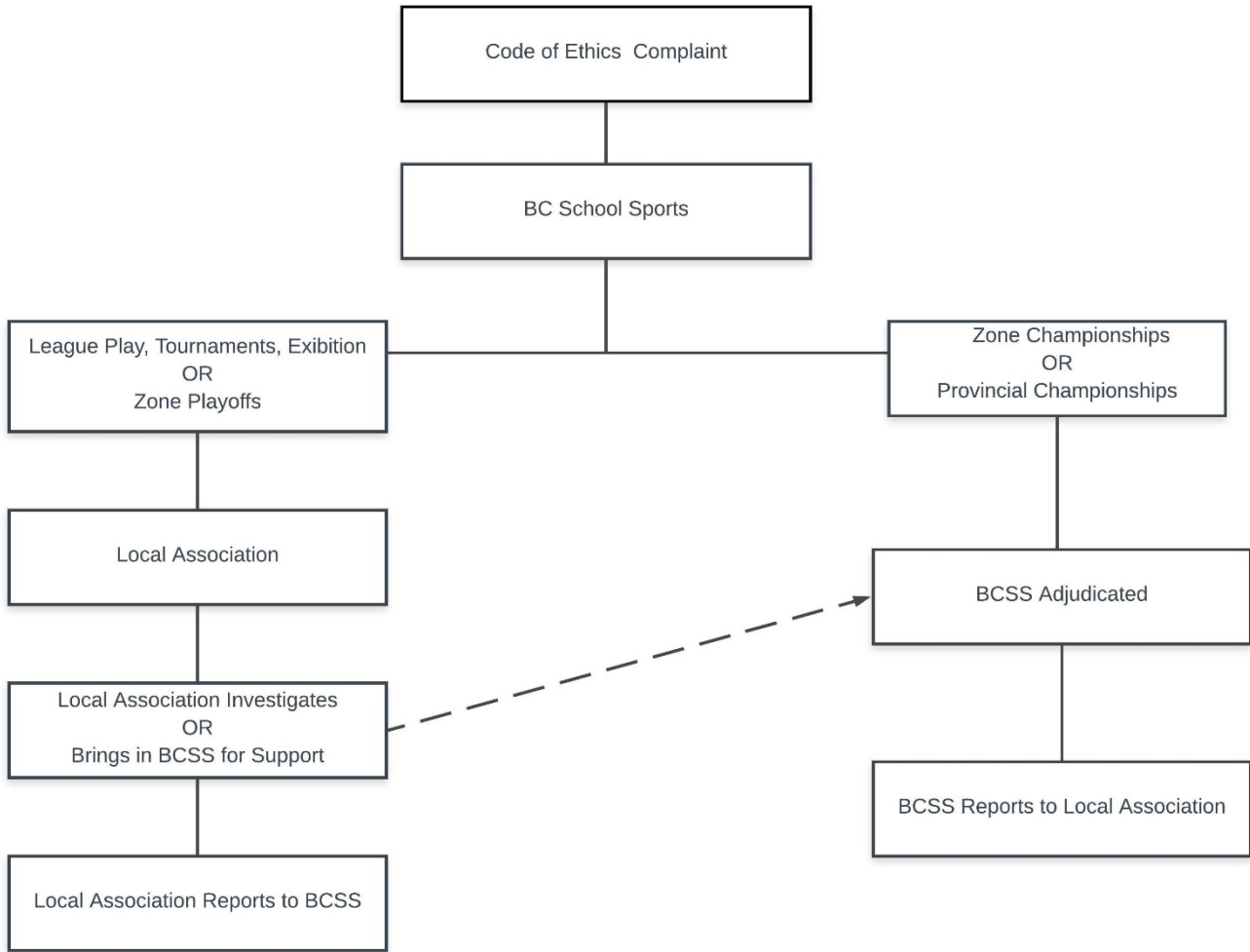

420.0 RECRUITMENT AND UNDUE INFLUENCE

A policy clearly prohibiting recruiting serves the interest of the organization by prioritizing academics over athletics; protecting young students from exploitation; ensuring an even playing field among competing schools; providing for equitable competition; discouraging adults from jeopardizing student's eligibility; and preventing misuse of athletic programs.

421.0 RECRUITING

BCSS prohibits the recruiting or inducement of student-athletes. Athletic recruitment undermines the priority of academic education for the student and promotes values that are inconsistent with those of BCSS. Stakeholders have a required duty to discourage an athletically motivated transfer. Failure to discourage a transfer that is athletically motivated constitutes recruitment. The fact that transfer eligibility has been approved in no way excuses recruitment.

- 421.1 Despite compliance with the other eligibility and/or transfer rules of BCSS, any student who attends a member school as a result of recruitment or undue influence is ineligible for a minimum of one-year. Violations under the policy may also result in sanctions to the school, athletic program, team or coach of the team.
- 421.2 Undue influence for the purposes of this rule is the attempt by any school related person (including but not limited to, coaches, teachers, administrators, students, alumni or parents) to induce a student through in-person contact, phone, text, social media, email, or the like, to attend a member school.
- 421.3 There are a broad range of behaviours that when considered alone, or in part are deemed to be recruitment. The facts of each allegation will be considered on a case by case basis. The following may indicate that a student has been recruited, but other actions not listed may still be considered:
- Initiating contact with any student who does not attend their school, or a school that as per School District procedures directly feeds into their school, in order to suggest, encourage or explain a transfer.
 - Encouraging any other person, including past and present players or parents of past or present players, to contact any student or their parents to suggest, encourage or explain a transfer to a different school.
 - Permitting a student who is not currently enrolled at a school to participate in team practices, participate in scheduled team activities (including travel to games, events, team meetings, or trips), attend "open gym", out- of-season practices, and camps specifically designated for enrolled students.
 - Engaging a student-athlete or parent when they inquire about the school's sports teams or athletic program. These inquiries must be directed to the school administration.
 - Offering or accepting financial assistance (including free or reduced tuition/fees) on the basis of a student's athletic potential or participation in a BCSS activity.
 - Offering or promising employment or other financial benefit to the student or any member of the student's family.
 - Offering or accepting transportation assistance to a student, parent or guardian.
 - Offering or accepting school privileges or considerations not normally granted to other students.
 - Offering or accepting assistance in securing a post-secondary athletic scholarship.
 - Suggestion or inducement of parents, guardians or students to change their location of residence for athletic reasons.
 - Facilitating a change of guardianship for the purpose of changing the location of a student athlete's residence so that they can transfer schools is recruitment unless there are other compelling reasons for the change of guardianship (e.g. to protect the student from physical or emotional abuse).
 - Discussion by a school related person in a club, community, or provincial team environment about their school, athletic program or team.

- 421.4 Any of the above listed or similar actions by a school related person are prohibited when targeted at any students, including those who have not established a home school, as per BCSS policy.
- 421.5 If a person has knowledge of recruitment, as defined herein, he or she shall provide written notice of the allegation to the BCSS Executive Director.
- 421.6 BCSS recognizes that schools may need to attract students. Schools may advertise their athletics program offerings in a generic manner, no different than they would any other academic or co-curricular program. The advertising must be limited to the programs offered and not highlight the success of the program, qualifications of a coach or any other identifier that would increase the chance of enrollment from a prospective student. School advertising, where athletics are included, must not be targeted in any way towards potential students who may display athletic potential.

422.0 PROCEDURE FOR COMPLAINTS REGARDING RECRUITING

- 422.1 Recruiting or undue influence complaints shall be submitted to the BCSS Executive Director in writing. Complaints submitted through any other submission method will not be accepted. The enrollment of a student at a school due to recruiting or undue influence must have happened while the student in question still held eligible status with BCSS (section 519.0). The complaint must include:
- The name of the school and, if applicable, person(s) allegedly having contravened the recruiting and undue influence policy;
 - The name of the student(s) who have been targeted by the recruiting action;
 - Some form of evidence to support the complaint. Evidence may come in the form of knowledge of or participation in a conversation, written documentation, or other forms of verifiable information. Hearsay, conjecture, rumour and the like will not be accepted.
- 422.2 The person making the complaint must disclose their name, and affiliation to a school (ie. admin, coach, student etc.) to BCSS. However, they may choose whether their name shall be attached to the complaint publicly, or if they wish to remain anonymous.
- 422.3 The Executive Director will review the complaint and determine whether the complaint warrants an investigation. The Executive Director may at his or her sole discretion, dismiss a complaint that:
- Is frivolous or made in bad faith;
 - Does not contain the relevant required information to substantiate the complaint;
 - Does not fall within the jurisdiction of BCSS.
- 422.4 Where the Executive Director dismisses the complaint, he/she will inform the complainant that the matter has been dismissed.
- 422.5 Where the Executive Director determines the allegation is worthy of investigation, he/she will inform the Principal of the respondent school that a complaint has been received, and a BCSS investigation is commencing.
- 422.6 Where BCSS discovers information through their normal course of business that indicates recruiting, the Executive Director, upon review of the information, may initiate an investigation without a complaint being submitted.
- 422.7 The Executive Director will conduct the investigation, and may make inquiries of any relevant party, including but not limited to, administrators, coaches, teachers, students, or parents.
- 422.8 Where the respondent fails to respond to the inquiries of the investigation, or chooses not to respond in ten (10) business days to these inquiries, the Executive Director may proceed on the basis the complaint has been proven.
- 422.9 Any information that is obtained that is not provided by the respondent school inquiries, shall be provided to the respondent school for review and response.

423.0 DISCIPLINE FOR RECRUITING

423.1 Upon completion of the investigation, the Executive Director will provide a ruling to the Principal of the respondent school, summarizing the findings of the investigation and if applicable, any sanctions. Sanctions will be determined by the Executive Director and may include part, or all, but shall not be limited to:

- An official letter of reprimand
- A sanction or combination of sanctions, that may include, but are not limited to,
 - The student-athlete in question
 - Period of ineligibility (minimum 1-year)
 - The member school
 - Suspension or Expulsion from BCSS Membership
 - Fine to a Maximum of \$3000
 - The member school athletic program
 - Suspension from zone or provincial play (team/sport specific, or school wide)
 - Mandatory Training for the AD or Administration
 - The specific team
 - Team ineligibility /Suspension of team
 - Forfeiture of games
 - Ban from post-season play
 - Reduction in maximum playing days in a season of play
 - The coach
 - Suspension from all coaching duties
 - Mandatory training

423.2 Once the ruling has been provided to the Administrator, the school will have ten (10) business days to appeal the ruling. The appeal must be made in writing and be addressed to the Executive Director. The appeal will be heard by a minimum of three (3) members of the Board of Directors. The appeal will be heard by video-conference or in person, at the discretion of the President or their designate.

423.3 At the conclusion of the appeal, in their discretion, the Board may choose to:

- remove all sanctions;
- reduce or add sanctions;
- take no action, leaving, the Executive Director's ruling to stand.

423.4 The decision of the Board of Directors is final and binding on the parties and shall not be questioned or reviewed in any court or tribunal, and no order shall be made or process entered or proceeding taken in any court or tribunal whether by way of injunction, declaration, prohibition or otherwise to question, review, prohibit or restrain the proceedings. It is the intention of BCSS and its members that, to the extent permitted by law, all matters concerning its Competitive Rules and Regulations be private matters not subject to any form of adjudication by any court or tribunal.

423.5 Where the Executive Director is unable to act under this section, his/her powers and duties may be exercised by a substitute as appointed by the President

430.0 HARASSMENT AND ABUSE

BC School Sports does not condone any form of harassment or abusive behavior on the part of any participant in BC School Sports programs, services and/or activities. BC School Sports is committed to providing an environment in which all individuals are treated with respect and dignity. Participants shall include any member school student-athlete, member school team coach, member school team manager, member school volunteer, recognized athletic association volunteer, BC School Sports volunteer, BC School Sports staff, spectator, official or event volunteer.

431.0 THE ROLE OF BC SCHOOL SPORTS

BCSS is committed to creating and maintaining a sport environment that is free from all forms of harassment and abuse for its members. BCSS will:

- 431.1 Discourage and prevent harassment within BCSS.
- 431.2 Provide assistance and guidance to individuals who experience harassment and pass the information into the appropriate organizations (Schools, School Districts or local police).
- 431.3 Ensure all members and employees of BCSS are aware of the negative impacts of harassment and abuse and educate them of the procedures contained in this policy.
- 431.5 Regularly review the terms of this policy to ensure that it meets BCSS's objectives and legal obligations.

432.0 DEFINITIONS

432.1 Harassment is defined as behavior including comments, conduct or gestures which are insulting, intimidating, humiliating, hurtful, malicious, degrading or otherwise offensive to an individual or group of individuals or which creates an uncomfortable environment, or which might reasonably be expected to cause embarrassment, insecurity, discomfort, offense, or humiliation to another person or group, including but not limited to:

- Written or verbal abuse or threats;
- Physical assault;
- Unwelcome remarks, jokes, innuendos or taunting about a person's body, sexual orientation, attire, age, marital status, ethnic or racial origin or religion;
- Displaying of sexually explicit, racist or other offensive or derogatory material, sexual, racial, ethnic or religious graffiti;
- Practical jokes which cause awkwardness or embarrassment, endangering a person's safety or negatively affecting performance;
- Hazing or initiation rites;
- Leering or other suggestive or obscene gestures;
- Intimidation;
- Condescension, paternalism or patronizing behavior which undermines self-respect or adversely affects performance or working conditions;
- Conduct, comments, gestures or contact of a sexual nature that is likely to cause offense or humiliation or that might, on reasonable grounds, be perceived as placing a condition of a sexual nature on employment or any opportunity for selection, training or advancement; and
- False accusations of harassment motivated by malice or mischief and meant to cause other harm, is considered harassment.

432.2 Sexual harassment is defined as behavior involving one (1) or more incidents of unwelcome sexual advances, requests for sexual favors or other verbal conduct of a sexual nature:

- When such conduct might reasonably be expected to cause embarrassment, insecurity, discomfort, offense or humiliation to another person or group;
- When submission to such conduct is made either implicitly or explicitly as a basis for making decisions which affect the individual;
- When submission to such conduct is made either implicitly or explicitly as a condition of employment;

- When submission to or rejection of such conduct is used as a basis for any decision of authority (including but not limited to matters of promotion, raise in salary, job security or benefits, and or participation or inclusion on a team); and
- When such conduct has the purpose or the effect of interfering with an individual's performance or creating an intimidating, hostile or offensive work or participation environment.

432.3 Abuse and neglect are defined as behavior involving one (1) or more incidents of physical, emotional, or sexual mistreatment or lack of care which causes physical injury or emotional damage to a participant:

- When such conduct might reasonably be expected to cause harm, distress or injury to another person or group;
- When submission to such conduct is made either implicitly or explicitly as a basis for making decisions which affect the individual;
- When such conduct creates a culture of fear among student-athletes, coaches, parents, volunteers or staff;
- When such conduct encourages or forces a participant to engage in destructive or harmful activities

433.0 ACCUSATIONS OF HARASSMENT

433.1 BC School Sports encourages any individual who is subjected to any form of harassment to report such harassment to the appropriate public school district, public school, independent school, BC School Sports or provincial sport organization, as designated below (volunteer is defined as an individual acting in their capacity of an event organizer, committee member, officer, director or other BC School Sports-assigned task):

- 433.1.1 Any incident of harassment or abuse, or accusation of harassment or abuse involving a student shall be referred to the applicable school district as per the particular school district's policy, or independent school as per the particular non-public school policy;
- 433.1.2 Any incident of harassment or abuse, or accusation of harassment or abuse involving an employee of a school district or independent school, when the employee is acting as a team coach, team sponsor, team chaperone, competition official or director of a local or regional athletic association, shall be referred to the applicable school district or independent school as per the particular school district's or non-public school's policy;
- 433.1.3 Any incident of harassment or abuse, or accusation of harassment or abuse involving an individual who is acting in their capacity as a director of BC School Sports, an employee of BC School Sports, a director of a BC School Sports sport commission or a volunteer organizer or worker of a BC School Sports sanctioned event, shall be dealt with as per the BC School Sports harassment policy;
- 433.1.4 Any incident of harassment or abuse, or accusation of harassment or abuse involving an individual who is a competition official at a BC School Sports sanctioned event shall also be referred to the provincial sport organization with whom the official is affiliated;
- 433.1.5 In the event of an incident of harassment or abuse, or accusation of harassment or abuse where there is duplicate jurisdiction between a school district or independent school and BC School Sports, or a provincial sport organization and BC School Sports, the disciplinary jurisdiction of BC School Sports is limited to an individual's involvement in BC School Sports programs and projects, including competitive involvement under the authority of a BC School Sports recognized athletic association or BC School Sports sport commission; and
- 433.1.6 BC School Sports shall name one (1) female and one (1) male BC School Sports Harassment Advisor who may be contacted for advice regarding any incident of harassment or accusation of harassment.

434.0 PROCEDURES FOR ACCUSATIONS OF HARASSMENT AND/OR ABUSE

434.1 An individual who thinks that they have been subjected to conduct which constitutes harassment (see 432) is encouraged to make it known to the person responsible for this conduct that the behaviour is not welcome and is contrary to this policy.

Any inquiry received by a BC School Sports Harassment Advisor will be dealt with as follows:

- 434.1.1 If the Harassment Advisor and complainant agree that the conduct does not constitute harassment, then the Harassment Advisor will take no further action.
- 434.1.2 Informal Resolution – The individuals involved will be invited to attempt an informal resolution with the BC School Sports Harassment Advisor mediating the meeting (i.e. conversation, conference call, meeting).
- 434.1.3 A confidential written summary report of the resolution telephone call or meeting will be sent to the administrator of the member school(s) involved, as well as to the complainant and respondent.

434.1.4 Rights of the Complainant – If an informal resolution is not possible, the Harassment Advisor shall inform the complainant of:

- a) The right to make a formal written complaint,
- b) The availability of counseling and other resources,
- c) The right to be represented by another designated individual at any stage in the complaint process. Any costs incurred by the complainant due to their decision to be represented by another individual will be the responsibility of the complainant,
- d) Other avenues of recourse, including the right to file a complaint to the BC Human Right Tribunal, or, where appropriate, to contact the police where the conduct may have been offensive pursuant to the Criminal Code.
- e) The referral of a formal harassment complaint received by BC School Sports to a Harassment Officer, as designated by Sport BC, for arms-length investigation.

434.2 FILING A FORMAL COMPLAINT

If the complainant wishes to file a formal complaint, the following steps will be followed:

- 434.2.1 A written complaint will be filed with a Harassment Advisor, with a copy going to the respondent and the administrator of the member school(s) involved.
- 434.2.2 The Harassment Advisor will provide the respondent with a written copy of the BC School Sports Harassment Policy, including a request for a written response to the complaint within ten (10) school days of receiving the information, and the right to be represented at any stage of the process by a designated individual. Any costs incurred by the respondent due to their decision to be represented by another individual will be the responsibility of the respondent.
- 434.2.3 Within sixty (60) days of receiving the initial written complaint, the Harassment Advisor shall conduct an investigation and prepare a written report. The investigation will follow the process of natural justice.
- 434.2.4 The investigative report from the Harassment Advisor will be submitted to the BC School Sports Executive Director, who shall:
 - a) Make a determination as to whether the respondent has engaged in conduct constituting harassment; and
 - b) If such determination is made, order such disciplinary action to be taken as is appropriate in the circumstances.

435.0 DISCIPLINE FOR HARASSMENT

435.1 EXECUTIVE DIRECTOR DECISION

The decision of the Executive Director will be made within ten (10) school days of receiving the report from the Harassment Officer, and will be sent to the complainant, the respondent and to the administrator of the member school(s) involved. BC School Sports will also inform the BCTF and the Teacher Regulation Branch if the respondent is a member.

435.2 APPEALING THE DECISION

The decision of the Executive Director may be appealed, in writing, by either the complainant or the respondent, within fifteen (15) school days of the original decision being rendered. The written appeal shall be directed to the BC School Sports Board of Directors

435.2.1 The Board of Directors will meet within ten (10) school days of receiving the written appeal.

435.2.2 The Board of Directors shall review all of the information compiled in the investigation, and meet with both the complainant and the respondent regarding the reasons that the appeal was filed. Meetings may be by conference call.

435.2.3 The decision of the Board of Directors may be to:

- a) Overturn the decision of the Executive Director by eliminating any penalty;
- b) Overturn the decision of the Executive Director by establishing a penalty;
- c) Overturn the decision of the Executive Director by increasing the penalty;
- d) Overturn the decision of the Executive Director by reducing the penalty; or
- e) Uphold the decision of the Executive Director.

435.2.4 The decision of the Board of Directors will be provided to the appellant within ten (10) days of completing their investigation. A copy of the decision will be sent to the complainant, the respondent and to the administrator of the member school(s) involved. BC School Sports will also inform the BCTF and the Teacher Regulation Branch if the

respondent is a member.

- 435.3 **BINDING DECISION**
The decision of the Board of Directors is final and binding on all parties.

440.0 MEDIA AND SOCIAL MEDIA

The BCSS Media and Social Media Policy identifies the standards of behavior which is expected of all BCSS members and participants including but not limited to; student-athletes, parents, guardians, coaches, officials, volunteers, spectators, teachers, BCSS staff and administrators involved in BCSS activities and events.

BCSS is committed to providing an environment in which all individuals are treated with respect. It is understood that many schools, teams and individuals may have websites or social media accounts and may have access to media outlets. Social media accounts can include but are not limited to; Twitter, Instagram, Facebook, Snapchat, TikTok, YouTube, blogs, etc.

Social media is a public domain which may be used to enhance opportunities in life and sport. The positive use of social media is acceptable and encouraged by BCSS. The following policies outline the BCSS Social Media Guidelines;

441.0 IMAGE

- 441.1 Content on social media shall portray a positive image of the participant, team, association and school.
- 441.2 All participants who have or moderate a social media account must conduct themselves in a positive manner that reflects as a healthy influence in their community.

442.0 COMMUNICATION

- 442.1 Social media may be used to promote BCSS activities or events (eg. Practices, games, tournaments etc.).
- 442.2 Inappropriate comments, pictures, racial slurs, threats against teammates, officials or opposing teams are prohibited. Social media may not be used to bully, harass or promote negative influences or criminal behavior.
- 442.3 The posting of personal or confidential information about a student-athlete, coach, official, staff member or volunteer is prohibited.

443.0 BEST PRACTICES

- Ensure consent has been provided for any individuals appearing in content intended for public domain.
- Include positive images and videos when possible.
- Provide shareable, relevant, value-driven content that supports the success and participation of teams, coaches, student-athletes and officials.
- Remember that sharing content online is permanent and is almost impossible to permanently remove from public domain.

444.0 VIOLATIONS

Should a violation(s) of the outlined guidelines occur they should be reported to BC School Sports and will be subject to an investigation. If a violation is found to have occurred, the participant(s) will be subject to disciplinary action under BCSS Bylaws.

500: COMMITTEES & MEETINGS

510.0 ANNUAL GENERAL MEETING

- 511.0** The Annual General Meeting (AGM) shall be held between February 1 and the final day of school.
- 512.0** Motions passed at the Annual General Meeting will come into effect on August 1st of that calendar year, unless otherwise stated in the motion. Eligibility related submissions for the next school year cannot be ruled on until new policies come into effect.
- 513.0** Legislative Assembly Members will be reimbursed for eligible expenses in accordance with the following:
513.1 Board of Directors; will be reimbursed for meals, travel, accommodation, and TOC costs where required;
513.2 Committee Chairs; will be reimbursed for meals, travel, accommodation, and TOC costs where required
513.3 Zone Representatives; provided accommodation
513.4 Partner Organizations; will be provided accommodation;
- Meals that are provided as normal course of the meetings will be provided to all attendees. Those meals are ineligible for reimbursement.

520.0 ANNUAL PLANNING MEETING

- 521.0** The BCSS Board of Directors will call an extraordinary meeting every fall to be known as the Annual Planning Meeting and shall be held between the first day of school and winter break
- 522.0** Any motions passed at the Annual Planning Meeting will come into effect on August 1st of that year, unless otherwise stated in the motion. Eligibility Applications for the next school year cannot be ruled on until new policies come into effect.
- 523.0** Legislative Assembly Members will be reimbursed for eligible expenses in accordance with section 533.0
523.4 Board of Directors; reimbursed for meals, travel, accommodation, and TOC costs where required;
523.1 Committee Chairs; reimbursed for meals, travel, accommodation, and TOC costs where required
523.2 Zone Representatives; provided accommodation
523.3 Partner Organizations; provided accommodation;
- Meals that are provided as normal course of the meetings will be provided to all attendees. Those meals are ineligible for reimbursement.

530.0 CONFLICT OF INTEREST AND CONFIDENTIALITY

Declaring affiliations provides the opportunity for members of a committee or legislative body to share their relationships, which may contribute or may be perceived to contribute to their opinions or positions. This ensures that members of the group are aware of other members' affiliations.

531.0 CONFLICT OF INTEREST

All members of the BCSS Board, Legislative Assembly and Committees are required to disclose any personal, professional and close familial connections or associations within education, sport or related sectors. By acknowledging one's affiliations, they are recognizing that while one may use the experience gained from these affiliations in your contributions, but that the participation and opinions shared are those of the group/seat one represents in the applicable BCSS Bylaws and Policies, or appropriate Committee Terms of Reference, and not sector affiliations you may hold.

Beyond the required standard disclosure required, a member of the Board of Directors, Legislative Assembly or BCSS committee will declare themselves to be in conflict of interest when discussing or deliberating any topic in which there may be the perception that a relationship or benefit may be impacting the deliberations or decision-making process, and specifically, but not limited to where:

- 531.1 there is the potential for a personal benefit, financial or otherwise to be gained
- 531.2 there is a close personal relationship between a member and someone or entity involved in the topic

532.0 CONFIDENTIALITY

The discussions, topics, deliberations and decisions made by any BCSS committee are considered confidential in nature, and shall not be discussed, disclosed nor referred to outside of the meeting setting unless permitted by the BCSS President, BCSS Executive Director, or applicable BCSS Committee Chair.

540.0 BCSS COMMITTEES

The Bylaws permit the BCSS Board of Directors or Legislative Assembly to create committees as required to perform the functions required of the organization. Committees may be policy committees, operating committees, or ad-hoc committees. As per the Bylaws, committees approved by the Legislative Assembly must have a Terms of Reference.

The BCSS President and Executive Director shall sit as ex-officio members of all committees, unless otherwise noted specifically in the Terms of Reference.

POLICY COMMITTEES

Policy committees are part of the governing process. The Chair of each Policy Committee receives a seat on the Legislative Assembly and the role of the committee is to make recommendations to the Legislative Assembly about changes to policy relative to their scope and

mandate.

541.0 COMPETITIVE FAIRNESS COMMITTEE

Committee Type: Policy – Standing

Committee Ownership: Board of Directors

541.1 PURPOSE

To make policy recommendations to the Legislative Assembly on all issues related to BC School Sports as it pertains to the goal of the maintaining competitive fairness and equity in an effort to provide equitable opportunity for success amongst all member schools.

541.2 MANDATE

The Competitive Fairness Committee shall solicit feedback, engage in research and discussion with internal and external stakeholders with the goal of making informed recommendations to the membership. Areas of focus should include, but are not limited to:

- The differences of rural versus urban schools
- Independent schools versus public schools
- The effect of international students or boarding students on competitive balance
- BCSS tiering structures and philosophy
- Any other policy or absence of a policy that has an impact on the ability for all schools to have an equitable opportunity to succeed

541.3 COMPOSITION & TERM OF APPOINTMENT

The Competitive Fairness Committee will consist of fourteen (14) members as appointed by the Board of Directors on the recommendation of the Executive Director. With the exception of those appointed by way of their position, all members will serve terms of 3-years. Members may serve up to two consecutive terms.

- Chairperson
- BCSS Board Member
- BCSS Executive Director*
- ISABC Executive Director*
- School District Administrator
- Head/Deputy Head from ISABC Member School
- Public School Administrator
- Athletic Director from non-ISABC Independent School
- Athletic Director from ISABC Independent School
- Athletic Director from a A/AA Public School
- Athletic Director from a AAA/AAA Public School
- Team Sport SAC Chair
- Individual Sport SAC Chair
- District Athletic Coordinator

*designates are appointed to the committee by way of their position

541.4 COMMITTEE MEETINGS:

The CFC meetings will be held a minimum of four times per year. Additional meetings can be called at the discretion of the Chair. Meeting will be held by video conference. The Chair, with approval from the Executive Director, may request an in-person meeting for the members of the committee. Quorum for meetings is the majority of the committee members as appointed.

The Chair, with support from the BCSS Staff Liaison shall distribute an Agenda prior to the meeting. Minutes shall be recorded and provided to the BCSS office for review and publication.

Where the Chair is unable to lead a meeting, the members may select a representative from the committee to chair the meeting.

BCSS will provide a staff liaison to work with the chair and committee membership.

541.5 AUTHORITY

The Competitive Fairness committee, by way of a simple majority vote, can bring motions for consideration by the Legislative Assembly.

A majority vote of the committee in favour does not change BCSS policy.

541.6 REMUNERATION

Committee members shall receive no remuneration for serving as committee members, but are entitled, to be reimbursed for all reasonable expenses incurred during the exercise of their duties as approved by the Board of Directors.

542.0 ELIGIBILITY APPEALS COMMITTEE

Committee Type: Policy – Standing

Committee Ownership: Board of Directors

542.1 PURPOSE

To adjudicate the appeals of the decisions of the Eligibility Officer(s) concerning a student-athlete's eligibility in accordance with eligibility and transfer rules.

542.2 MANDATE

The EAC shall read, understand, discuss and evaluate each appeal on an individual basis. The committee shall then consider the information in the application and shall approve or deny the appeal, having regard to the purposes, bylaws, and policies of BC School Sports.

The committee is granted the authority to grant exceptions to the policies of the organization as it pertains to student-athlete eligibility, generally, but not limited to, on the grounds of extraordinary and/or compassionate grounds.

The Committee shall issue a ruling to the applicant school either approving or denying the appeal and containing a brief summary of the reasons for their decisions. The decisions of the EAC are final and binding and shall not be questioned or reviewed in any court or tribunal.

542.3 COMPOSITION & TERM OF APPOINTMENT

The EAC chairperson will be appointed by the board and must be a school or district administrator. The Chair is a voting member of the Legislative Assembly, but generally will be used as a tie-breaking vote when required. Should the EAC Chair be unable to attend a meeting or declares a conflict of interest with a particular appeal, the Chair may designate another member of the EAC to chair the meeting or portion thereof. The individual assuming the position of chairperson assumes the tie-breaking voting role while in the chair. The designated Chair does not need to be an administrator.

The EAC will consist of seven (7) members as appointed by the Board of Directors, each for a four-year term, which can be renewed once consecutively. All members must be employed by a member school or school district. A minimum of two (2) committee members must be school or district administrators.

542.4 COMMITTEE MEETINGS

The EAC will meet as set by the BCSS Board of Directors in the BCSS calendar; up to a maximum of 10 meetings per year. The EAC may meet by conference call or video conferencing if warranted by time and expense. The manner in which the EAC will meet is the decision of the chairperson of the EAC.

A minimum of 50% of all appointed members of the EAC must be in attendance in order that appeals can be heard.

Meeting minutes will be recorded to provide a record of the decisions of the EAC including their rationale and context for their decisions. These minutes will be provided to BCSS.

Unless requested specifically by the Chair, neither the President nor the Executive Director will not attend the EAC meetings.

The committee will note other policy or procedures as noted in the applicable eligibility section of the BCSS handbook.

542.5. AUTHORITY

The EAC will by majority vote, determine the outcome of Eligibility appeals. These decisions are final and binding. The EAC, at their discretion, may make exceptions to BCSS Eligibility policies on the basis of extraordinary or compassionate grounds.

542.6. REMUNERATION

Committee members shall receive no remuneration for serving as committee members, but are entitled, to be reimbursed for all reasonable expenses incurred during the exercise of their duties as approved by the Board of Directors.

543.0 SPORTS CHAMPIONSHIP COMMITTEE

Committee Type: Policy – Standing

Committee Ownership: Board of Directors

These terms of reference apply to the following two (2) separate committees:

- Team Sports Championship Committee
- Individual Sports Championship Committee

543.1. PURPOSE

Through comprehensive research and discussion, examine policy related to BCSS Championships, and make recommendations to the Legislative Assembly ensuring a common review process and shared multi-sport philosophy amongst championships.

543.2. MANDATE

- Evaluate BCSS policy related to championships such as, but not limited to:
 - Size of Championships (Number of participating teams and/or athletes)

- Structure of Championships (Round Robin, Power Pools, Crossover, Double Elimination etc.)
- Berthing (Process for awarding championship berths)
- Seeding and Ranking Process and Procedures (process for determining Championship seeding)
- Discipline and Appeal Policies for Zone and Provincial Championship contests
- Host Rotations and Responsibilities

543.3. COMPOSITION & TERM OF APPOINTMENT

Each Championship Committee will be chaired by a person who is elected by the Legislative Assembly. The chair must be an Athletic Director or Administrator at a Member School or School District; a current or past BCSS Zone President; a current or past Local Association President; or a District Athletic Coordinator. The Term of the Chair is 3 years. The Chair, by virtue of their election is also a member of the Legislative Assembly.

Each sport in the appropriate committee will be represented by one individual who is appointed by the Sport Advisory Committee for their sport. The term for the SAC Appointed Members is 2 years. The SAC appointee must be employed by a member school or school district.

NOTE: Basketball and Volleyball will have one each for boys and girls, until the SAC's merge in 2023-2024

The sports represented in each committee are as follows:

- Individual Sport Committee: Aquatics, Cross-Country, Gymnastics, Mountain Biking, Snowboarding, Track & Field, Wrestling
- Team Sport Championship Committee: Badminton, Basketball, Curling, Field Hockey, Football, Golf, Rugby, Soccer, Tennis, Ultimate, Volleyball

543.4. COMMITTEE MEETINGS

Each Committee will meet at minimum three times per year. Additional meetings can be called at the discretion of the Chair. Meetings will be held by video conference. The Chair, with approval from the Executive Director, may request an in-person meeting for the members of the committee.

The Chair, with support from the BCSS Staff Liaison shall distribute an Agenda prior to the meeting. Minutes shall be recorded, and provided to the BCSS office for review and publication.

The committee will require a minimum of 50% of appointed members to constitute quorum.

Where the Chair is unable to lead a meeting, the members may select a representative from the committee to chair the meeting.

BCSS will provide a staff liaison to work with the chair and committee membership.

543.5. AUTHORITY

The Championship committee, by way of a simple majority vote, can bring motions for consideration by the Legislative Assembly. A majority vote in favour does not change BCSS policy.

543.6. REMUNERATION

Committee members shall receive no remuneration for serving as committee members, but are entitled, to be reimbursed for all reasonable expenses incurred during the exercise of their duties as approved by the Board of Directors.

544.0 SPORT MEDICINE AND ATHLETE SAFETY COMMITTEE

Committee Type: Policy – Standing

Committee Ownership: Board of Directors

544.1 PURPOSE

To examine all issues related to athlete safety of participants in school sports and make policy recommendations to the legislative assembly accordingly.

544.2 MANDATE

The Sport Medicine & Athlete Safety Committee (SMASC) is a committee appointed by and responsible to the Board of Directors that shall solicit feedback, engage in research and discussion with internal and external stakeholders with the goal of making informed recommendations to the Legislative Assembly. Areas of focus should include, but are not limited to:

- Safety standards and risk management for school sport events
- Concussion education and return to education and return to play protocols
- Injury statistics and trend identification
- Research opportunities, best practices education related to overuse, sport specialization, and any other policy or absence of a policy that has the ability to increase student-athlete safety and well being

544.3 COMPOSITION & TERM OF APPOINTMENT

The Sport Medicine & Athlete Safety Committee will consist of 9 members as appointed by the Board of Directors on the recommendation of the Executive Director with thought towards achieving the appropriate diversity and knowledge on the committee. Members will be serve two-year terms as follows:

- Committee Chair
- Football SAC – Safety and Coach Education Coordinator
- Athletic Association President
- Member School Principal

- Member School Athletic Director
- BCSS Board of Director
- External – Athletic Therapist
- External – Sport Medicine Physician
- External – Concussion Expert

544.4. COMMITTEE MEETINGS

The Sport Medicine and Athlete Safety committee meetings will meet a minimum of three times per year. Additional meetings can be called at the discretion of the Chair. Meetings will be held by video conference. The Chair, with approval from the Executive Director, may request an in-person meeting for the members of the committee.

The Chair, with support from the BCSS Staff Liaison shall distribute an Agenda prior to the meeting. Minutes shall be recorded, and provided to the BCSS office for review and publication.

The committee will require a minimum of 50% of appointed members to constitute quorum.

Where the Chair is unable to lead a meeting, the members may select a representative from the committee to chair the meeting. BCSS will provide a staff liaison to work with the chair and committee membership.

Ad-Hoc or Sub-Committee:

The SMASC can at the discretion of the chair, form a sub- or ad-hoc committee to address issues requiring specific expertise and may recruit members from the school sport or medical/safety community at large, if necessary. There must be at least two committee members appointed to a sub- or ad-hoc committee. The committee should be task-specific, time-limited and is dissolved once the recommendations are moved forward.

544.5 AUTHORITY

The Sport Medicine and Athlete Safety Committee, by way of a simple majority vote, can bring motions for consideration by the Legislative Assembly. A majority vote in favour does not change BCSS policy.

544.6 REMUNERATION

Committee members shall receive no remuneration for serving as committee members, but are entitled, to be reimbursed for all reasonable expenses incurred during the exercise of their duties as approved by the Board of Directors.

545.0 SPORTS RULES COMMITTEE

Committee Type: Policy – Standing

Committee Ownership: Board of Directors

These terms of reference apply to the following three (3) separate committees:

- Fall Sports Rules Committee
- Winter Sports Rules Committee
- Spring Sports Rules Committee

545.1 PURPOSE

To examine all issues related to athlete rules for the sports within their season of play and make policy recommendations to the Legislative Assembly accordingly.

545.2 MANDATE

Each committee is focused on the rules of play for the sports in their season of play including:

- Technical Rules and Game Protocols
- Field of Play Specifications/Requirements
- Uniforms
- Equipment
- Officials/Scoring

545.3 COMPOSITION & TERM OF APPOINTMENT

Each Sport Rules Committee will be chaired by a person who is elected by the Legislative Assembly. The chair must be an Athletic Director or Administrator at a Member School or School District; a current or past BCSS Zone President; a current or past Local Association President; or a District Athletic Coordinator. The Term of the Chair is 3 years. The Chair, by virtue of their election is also a member of the Legislative Assembly.

Each Sports Rules Committee will have one female and one male expert from each sport that are appointed by the Sport Advisory Committee (SAC). The term for the Sports Rules Committee is 2 years. The SRC appointee must be employed by a member school or school district.

545.4. COMMITTEE MEETINGS

Each Committee will meet at minimum two times per year. Additional meetings can be called at the discretion of the Chair. Meetings will be held by video conference. The Chair, with approval from the Executive Director, may request an in-person meeting for the members of the committee.

The Chair, with support from the BCSS Staff Liaison shall distribute an Agenda prior to the meeting. Minutes shall be recorded, and provided to the BCSS office for review and publication.

The committee will require a minimum of 50% of appointed members to constitute quorum.

Where the Chair is unable to lead a meeting, the members may select a representative from the committee to chair the meeting. BCSS will provide a staff liaison to work with the chair and committee membership.

545.5 REMUNERATION

Committee members shall receive no remuneration for serving as committee members, but are entitled, to be reimbursed for all reasonable expenses incurred during the exercise of their duties as approved by the Board of Directors.

546.0 TIERING & SPORT EVALUATION COMMITTEE

Committee Type: Policy – Standing

Committee Ownership: Board of Directors

546.1 PURPOSE

To thoroughly research and make recommendations to the Legislative Assembly related to issues of Tiering and Sport Evaluation.

546.2 MANDATE

The Tiering and Sport Evaluation (TSE) Committee will make recommendations to the Legislative Assembly on tiering thresholds, structures and timelines. This committee is responsible to make recommendations for the addition and removal of sports based on established criteria and data. The committee will create and evaluate the application process for adding new sports.

546.3 COMPOSITION & TERM OF APPOINTMENT

The TSE membership will consist of the following members:

- BCSS Board of Directors Member (Chair)
- Team Sport Championship Committee Member
- Individual Sport Championship Committee Member
- BC Schools Superintendent Association Representative
- BC Principals and Vice Principals Association Representative
- BCSS Executive Director

The Chair will be appointed from the Board of Directors for a period. While one representative from each of the Team Sport and Individual Sport Championship Committees will also be appointed by the Board. Each of these members will serve a 2-year term, renewable no more than 3 consecutive terms. The BCSSAA and BCPVPA representative will be appointed as a result of their organization's appointment to the Legislative Assembly and their term will be for the duration of the appointment to the BCSS Legislative Assembly.

546.4 COMMITTEE MEETINGS

The TSE will meet a minimum of two times per year. Additional meetings can be called at the discretion of the Chair. Meetings will be conducted by video conference. The Chair, with approval from the Executive Director, may request an in-person meeting for the members of the committee.

The Chair, with support from the BCSS Staff Liaison shall distribute an Agenda prior to the meeting. Minutes shall be recorded, and provided to the BCSS office for review and publication.

The committee will require a minimum of 50% of appointed members to constitute quorum.

Where the Chair is unable to lead a meeting, the members may select a representative from the committee to chair the meeting. BCSS will provide a staff liaison to work with the chair and committee membership.

546.5 AUTHORITY

The Tiering & Sport Evaluation committee, by way of a simple majority vote, can bring motions for consideration by the Legislative Assembly. A majority vote in favour does not change BCSS policy.

546.6 REMUNERATION

Committee members shall receive no remuneration for serving as committee members, but are entitled, to be reimbursed for all reasonable expenses incurred during the exercise of their duties as approved by the Board of Directors.

OPERATING COMMITTEES

Operating committees are created to assist the staff in providing a critical service, program or deliverable to the membership. They are not part of the legislative process, but may provide feedback relevant to policy changes were required.

547.0 CHAMPIONSHIP HOST COMMITTEES

Committee Type: Operational

Committee Ownership: Board of Directors

547.1. PURPOSE

To lead in the planning and delivery of BCSS Championships consistent with BCSS policy to create quality and memorable events for student-athletes. There will be 25-35 host committees each year for each BCSS championship event.

547.2 MANDATE

Each BCSS Championship is slightly different in nature, however, generally speaking every championship will have a committee responsible for the following:

Planning and Delivering the BCSS Provincial Championships in a manner consistent with BCSS policy

- Developing the Championship Schedule
- Liaising and providing appropriate services for officials
- Working with technical officials and BCSS office staff
- Facilitate livestreaming (where applicable)
- Program design and printing (where applicable)
- Ticket sales, crowd control and safety measures
- Communication with and hospitality of coaches and VIP's
- Obtaining local sponsorship
- Sourcing and providing the required volunteers
- Facility Planning
- Emergency Action Plan
- Support Apparel Sales (where applicable)
- Post Event Report

547.3 COMPOSITION & TERM OF APPOINTMENT

Composition will vary based on the requirements of each event. Some championships may only have a committee of 5-7, while others may have a committee of 15-20.

In general, each championship will have a person or persons responsible for these key areas, but may more areas they assign to committee members:

- Tournament Chair (or co-chairs)
- Media and Communications
- Officials/Minor Officials
- Sponsorship
- Accreditation, Logistics and Hospitality

The term is for the duration of the period leading up to and during the event. After the final report is submitted, the committee is dissolved. There is no requirement for committee members or the chair to be an employee of a member school or district.

547.4 AUTHORITY

The championship host committees do not have a legislative function but are essential in hosting provincial championship and providing feedback and ideas to the appropriate legislative committees.

547.5 REMUNERATION

Committee members shall receive no remuneration for serving as committee members, but are entitled, to be reimbursed for all reasonable expenses incurred during the exercise of their duties as approved by the Board of Directors.

548.0 HISTORY & ARCHIVES COMMITTEE

Committee Type: Operational - Standing

Committee Ownership: Board of Directors

548.1 PURPOSE

To ensure that BCSS events of historical significance, sport, organizational, and individual, are documented, preserved and archived in an appropriate way so that they can be found and appropriately celebrated.

548.2 MANDATE

- Provide a framework, system and method for tracking and archiving championship history such as tournament results, tournament locations, team and individual records
- Provide a framework, system and method to document and archive organizational history and decisions or periods of significance such as major changes to organizational structure or philosophy, the addition or removal of sports, key

volunteers, government relations, donors, logos and other visual representations of the organization, or any other item the committee feels is of historical significance.

- Provide a framework, system and method for capturing and archiving useful data captured by BCSS for historical comparisons.
- Assist staff in developing, and maintaining record books and other useful documents or projects to celebrate the history and achievements of member schools and individuals

548.3 COMPOSITION & TERM OF APPOINTMENT

The committee will have a chair as appointed by the Board of Directors, at the recommendation of the Executive Director. The committee will consist of 6-15 members. This committee is open to anyone interested and may be of particular interest to retired teachers or coaches. Terms shall be 3 years in length, with no cap on the number of terms served by any individual. The committee will have a staff liaison to assist its work.

548.4 COMMITTEE MEETINGS

The committee will meet a minimum of two times per year and may do so more at the discretion of the Chair. Meetings will be held by video conference. The committee, with approval from the Executive Director, may request an in-person meeting for the members of the committee.

548.5 REMUNERATION

Committee members shall receive no remuneration for serving as committee members, but are entitled, to be reimbursed for all reasonable expenses incurred during the exercise of their duties as approved by the Board of Directors.

549.0 RANKING COMMITTEE

Committee Type: Operational

Committee Ownership: Board of Directors

These terms of reference apply to the sports that currently use rankings (Football, Boys Volleyball, Girls Volleyball, Boys Basketball and Girls Basketball) and will also apply to any sports that subsequently add a ranking process

549.1 PURPOSE

In the sports that use weekly or bi-weekly rankings as a way to generate interest in the season as well as create a small foundation for which eventual Championship Seeding can be based.

549.2 MANDATE

Each committee would execute the ranking process which would be stewarded by BCSS staff on a weekly or biweekly basis, with the coaches on the committee submitting their rankings in an approved method to be consolidated by BCSS for publication.

549.3 COMPOSITION & TERM OF APPOINTMENT

Each committee will have a chair which will be appointed by the Board of Directors based on an expression of interest. Ranking committees would consist of an active coach from each BCSS Zone. There is no requirement that the coach is an employee of a member school or district. Where reasonable there may be subcommittees for the different tiers within a sport.

549.4 COMMITTEE MEETINGS

Each committee will meet virtually on a need to basis leading up to provincial championships.

549.5 AUTHORITY

The committee has no legislative function but is essential in providing feedback and ideas to the appropriate legislative committee.

549.6 REMUNERATION

Committee members shall receive no remuneration for serving as committee members, but are entitled, to be reimbursed for all reasonable expenses incurred during the exercise of their duties as approved by the Board of Directors.

550.0 SCHOLARSHIP COMMITTEE

Committee Type: Operational - Standing

Committee Ownership: Board of Directors

550.1 PURPOSE

Responsible for reviewing and selecting all BCSS Scholarship recipients against the set criteria.

550.2 MANDATE

The Scholarship Committee shall read, discuss and evaluate each scholarship application and select the most worthy candidates based on the pre-determined criteria set by the BCSS staff and/or donor/sponsor.

550.3 COMPOSITION & TERM OF APPOINTMENT

The committee is made up of 5 individuals who are all employed by a member school or school district and will be appointed by the Board of Directors at the recommendation of the Executive Director. Each committee member will serve a two-year term which can be reviewed up to three times.

The committee chair will be one of the five appointees.

BCSS will provide a staff liaison to work with the chair and committee membership.

550.4 COMMITTEE MEETINGS

The committee will meet virtually on a need to basis.

550.5 REMUNERATION

Committee members shall receive no remuneration for serving as committee members, but are entitled, to be reimbursed for all reasonable expenses incurred during the exercise of their duties as approved by the Board of Directors.

551.0 SPORT ADVISORY COMMITTEE

Committee Type: Operational

Committee Ownership: Board of Director

Each BCSS Sport will have a Sport Advisory Committee. For the sake of supporting this transition, basketball and volleyball who currently have gender specific commissions, will have a period of two years where they can have a gendered Sport Advisory Committee, before they become a single non-generated SAC for each volleyball and basketball. Due to the nature of Football not being contested at the zone level the committee composition will not be derived from the zones.

These terms of reference apply to all sports with the exception of those that have alternative Terms of Reference specific to their sport.

551.1 PURPOSE

To provide a forum for sport specific dialogue and providing support for the continued growth and development of our coaches and sports

551.2 MANDATE

- Appointing the two (2) representatives for their sport to the appropriate rules committee
- Appointing the one (1) representative for their sport to the appropriate championship committee
- Providing sport specific feedback on championships, rules, and other sport specific matters of importance to the coaches and student-athletes
- Working with BCSS staff to coordinate and deliver workshops, courses, and other development and networking opportunities for coaches around the province
- Assist the BCSS staff with the securing and requesting of officials

551.3 COMPOSITION & TERM OF APPOINTMENT

Each BCSS zone will then appoint one person for each of the BCSS Sport Advisory Committees. Each committee will then consist of ten people. Each SAC chair will be appointed by the Board of Directors upon the submission of an expression of interest. Each BCSS zone will be required to annually appoint one representative from their zone for each sport. There is not a limit to the number of terms a representative can serve. Zone reps do not have to be educators but should be active coaches that are appointed by each BCSS zone.

551.4 COMMITTEE MEETINGS

Each Committee will meet a least once per year. Additional meetings can be called at the discretion of the Chair. Meetings will be held by video conference. The Chair, with approval from the Executive Director, may request an in-person meeting for the members of the committee

551.5 AUTHORITY

The committee has no legislative function but is essential in providing feedback and ideas to the appropriate legislative committee.

551.6 REMUNERATION

Committee members shall receive no remuneration for serving as committee members, but are entitled, to be reimbursed for all reasonable expenses incurred during the exercise of their duties as approved by the Board of Directors.

552.0 BOYS BASKETBALL SPORT ADVISORY COMMITTEE

Committee Type: Operational

Committee Ownership: Board of Director

For the sake of supporting the governance transition, boys basketball operate a gendered Sport Advisory Committee with a slightly altered Terms of Reference, before they become a single non-generated SAC for basketball for the 2023-2024 season in alignment with the other sport SAC's. The boys basketball sport advisory committee section will automatically be removed for the 2023-2024 section.

552.1 PURPOSE

To provide a forum for sport specific dialogue and providing support for the continued growth and development of our coaches and sports.

552.2 MANDATE

- Appointing the two (2) representatives for their sport to the appropriate rules committee
- Appointing the one (1) representative for their sport to the appropriate championship committee
- Providing sport specific feedback on championships, rules, and other sport specific matters of importance to the coaches and student-athletes
- Working with BCSS staff to coordinate and deliver workshops, courses, and other development and networking opportunities for coaches around the province

- Assist the BCSS staff with the securing and requesting of officials

552.3 COMPOSITION & TERM OF APPOINTMENT

Each BCSS zone will appoint one person to the Boys Basketball Sport Advisory Committee. In addition to the nine (9) zone representative there will also be up to three (3) members-at-large who will be appointed by the Board of Directors based on recommendations from the SAC Chair and the Executive Director.

The SAC chair will be appointed by the Board of Directors upon the submission of an expression of interest. Each BCSS zone will be required to annually appoint one representative from their zone for this committee. There is not a limit to the number of terms a representative can serve. Zone reps do not have to be educators but should be active coaches that are appointed by each BCSS zone.

552.4 COMMITTEE MEETINGS

The Committee will meet a least once per year. Additional meetings can be called at the discretion of the Chair. Meetings will be held by video conference. The Chair, with approval from the Executive Director, may request an in-person meeting for the members of the committee.

552.5 AUTHORITY

The committee has no legislative function but is essential in providing feedback and ideas to the appropriate legislative committee.

552.6 REMUNERATION

Committee members shall receive no remuneration for serving as committee members, but are entitled, to be reimbursed for all reasonable expenses incurred during the exercise of their duties as approved by the Board of Directors.

553.0 FOOTBALL SPORT ADVISORY COMMITTEE

Committee Type: Operational - Standing

Committee Owner: Board of Directors

553.1 PURPOSE

As football is run provincially and does not follow the zone model as all other BCSS sports do, the Football SAC provides operational expertise to deliver the football season from the regular season through to the Championship. Additionally, it provides a forum for Football specific dialogue and providing support for the continued growth and development of our coaches and the sport.

553.2 MANDATE

- Working in collaboration with the BCSS Staff, operationalize the Football season, for things such as, but not limited to, scheduling, officials' coordination, event sponsorship, coach training, safety certifications, HUDL, website etc.
- Appoint the two (2) football representatives to the Fall Sports Rules Committee
- Appoint the one (1) football representative to the Team Sports Championship Committee
- Solicit sport-specific feedback from coaches and other stakeholders on championships, rules, and other sport-specific matters as a conduit to BCSS, the Board of Directors, policy committees and Legislative Assembly.
- Work in collaboration with BCSS staff to coordinate and deliver workshops, courses, and other development and networking opportunities for coaches around the province

553.3 COMPOSITION & TERM OF APPOINTMENT

The Football SAC chair will be appointed by the Board of Directors, upon the submission of an expression of interest. All other committee members will be named by the Board of Directors at the recommendation of the Chairperson and the Executive Director. Committee members are NOT required to be employed by a school or school district.

- Chairperson
- AAA Conference Coordinator
- AA Conference Coordinator
- Junior Football Coordinator
- Grade 8 Football Coordinator
- Interior Representative
- Northern Representative
- Island Representative
- Hudl Coordinator
- Discipline Coordinator
- Communications Coordinator
- Championship Director
- Safety Coordinator
- Coach Education & Development Coordinator

553.4. COMMITTEE MEETINGS

Due to the operational nature of this committee, the committee will meet monthly leading up to and during the season of play, and then as required,

at the discretion of the Chair during the rest of the year.

553.5 AUTHORITY

The committee has no legislative function and may not change BCSS policy but will work in tandem with BCSS staff to solve operational issues that arise. Additionally, they will provide sport-specific guidance and feedback to the legislative process regarding their sport.

553.6 REMUNERATION

Committee members shall receive no remuneration for serving as committee members but are entitled, to be reimbursed for all reasonable expenses incurred during the exercise of their duties as approved by the Board of Directors.

Members of the committee may receive a Contract for Service to perform specific duties as required time-to-time by BCSS.

**600: SEASONS OF PLAY, TIERING,
& SANCTIONING**

610.0 BC SCHOOL SPORTS OFFICIAL ACTIVITIES

611.0 BC School Sports recognizes and therefore governs the following as BCSS interscholastic activities. Activities are categorized as team or individual and are contested in their designated seasons of play:

<i>BCSS Activities</i>		
<i>Season</i>	<i>Team</i>	<i>Individual</i>
Fall	Football	Aquatics
	Field Hockey	Cross Country
	Boys Soccer	
	Volleyball	
Winter	Basketball	Gymnastics
	Curling	Skiing
		Snowboarding
		Wrestling
Spring	Badminton	Mountain Biking
	Golf	Track and Field
	Girls Soccer	
	Rugby (15-a-side)	
	Tennis	
	Ultimate	

612.0 GOALS OF ACTIVITY SELECTION

To promote and maintain activities which enhance the educational experience, and are appropriate to the school system, based on coaching, facilities, and technical resources available.

613.0 NATIONAL CHAMPIONSHIPS

BCSS, in conjunction with other member associations, support the School Sport Canada Statement on National Championships, and therefore no events of this nature will be sanctioned by BCSS.

620.0 SEASONS OF PLAY

The rules in this section are aimed at balancing interscholastic sport activity throughout the school year and fostering a balance for student-athletes between interscholastic sports and other activities. The intent of establishing seasons of play is to provide parameters as to when particular BCSS sanctioned competitions may occur. Within a season of play a member school's coaches and administrators are encouraged to cooperate in scheduling matters and facility and resource use to maximize opportunities for student-athletes.

621.0 The season of play begins on the date listed in each sport section in section 1000. The season of play will end on the last day of the provincial championship for the sport in question.

622.0 Member schools may only participate in official BCSS activities during the designated season of play as outlined in 611.0. Exceptions to this rule are noted in 647.0 – 648.0.

623.0 No member school shall participate in scrimmages (definitions) outside the designated seasons of play.

624.0 PLAYING OUTSIDE THE SEASON OF PLAY - BCSS member schools may only compete in a BCSS activity against other member schools within the designated season of play. BCSS recognizes some students will wish to continue to play their sport outside the school season of play. To do this, the student-athletes must compete on a club/community team. Ideally, club/community teams are an aggregate of players from the community and not identical to the school team. A club/community team may not:

- 624.1 Wear school uniforms, colours or apparel
- 624.2 Use the school name or mascot name
- 624.3 Use school transportation
- 624.4 Require a student to play on the club/community team to be a member of the school team
- 624.5 Advertise or promote the club/community program on school social media channels

625.0 In addition to the above, the club/community team must:

- 625.1 Be a member of the Provincial Sport Organization (PSO)
- 625.2 If accessing school facilities, receive acknowledgement from the school administrator that the team is a club/community team and therefore is not a recognized school activity
- 625.3 Have a rental agreement for school gym time as a third party and the appropriate insurance. The rental costs may be reduced at the discretion of the school district or school.

626.0 With approval from the BCSS Board of Directors, an affiliated local association may alter the Grade eight (8) and grade nine (9) seasons of play.

627.0 SEASON OF PLAY INFRACTION PROCEDURES AND PENALTIES

Infractions may be in violation of but are not limited to; playing outside of season of play, or exceeding the number of play days. Upon discovery of a Season of Play infraction, the Executive Director shall not make a determination without first giving the member school notice of the allegation and the opportunity to be heard concerning the allegation.

- 627.1 A member school shall submit promptly such information or documentation as may be required by the Executive Director for the purpose of making a determination under section 620.0
- 627.2 Following communication with the member school in question, through a written summary of the reasons for the determination, it is at the discretion of the Executive Director to enforce;
- 627.3 In the case of competition played above the maximum number of playing days, the school in violation will be subject to penalties at the discretion of the Executive Director. Penalties may include but are not limited to, reduction in overall allowable playing days, forfeiture, suspension, disqualification from post-season play and/or monetary fines. Fines against the member school will be calculated as follows and payable within thirty (30) school days of a written determination notice being made by the Executive Director:
 - 627.3.1 a minimum of \$300 if no violation of this section by the school in the past three (3) years;
 - 627.3.2 a minimum of \$500 if one (1) violation of this section by the school in the past five (5) years; or
 - 627.3.3 a minimum \$1000, to a maximum of \$3000 if more than one (1) violation of this section by the school in the past five (5) years.
- 627.5 There is no appeal from a determination under this section. A determination is final and binding and shall not be questioned or reviewed in any court or tribunal, and no order shall be made or process entered or proceeding taken in any court or tribunal whether by way of injunction, declaration, prohibition or otherwise to question, review, prohibit or restrain the proceedings. It is the intention of BCSS and its members that, to the extent permitted by law, all matters concerning its Bylaws and Policies be private matters not subject to any form of adjudication by any court or tribunal.

630.0 SCHOOL ENROLLMENT AND TIERING CLASSIFICATIONS

631.0 ESTABLISHING SCHOOL ENROLLMENT NUMBERS

To determine sport tiering classifications, member school population numbers will be calculated using the previous year's grade ten (10), grade eleven (11), and Secondary Ungraded (SU) numbers as submitted September 30th to the Ministry of Education on the 1701 report.

632.0 SCHOOL ENROLLMENT APPEALS

School enrollment appeals can be submitted to BCSS until October 1st of the current school year. Accepted appeals will determine the member schools enrollment numbers for all sports for a one (1) year period.

632.1 Appeals can be submitted for the following:

- Addition or deletion of grades in a member school;
- School/District Re-organization; or
- Changes in enrolment in excess of five percent (5%) of the current year’s grade eleven (11) and grade twelve (12) (senior grades) students in a member school compared to the previous year’s 1701

632.2 Appeals will not be accepted for the following:

- Changes or reclassification of secondary ungraded students in a member school; or
- Generalized fluctuation of less than five percent (5%) of the current year’s grade eleven (11) and grade twelve (12) (senior grades) students in a member school

633.0 SPORT SPECIFIC REQUESTS FOR CHANGE OF TIERING:

A School wishing to compete in a different tier are to submit a tiering classification change application no later than 7 days prior to the team registration deadline. The application is to be completed on the appropriate form and include a rationale for the tiering change, Athletic Directors and Principals are encouraged to get input from coaches prior to submitting the application to the Executive Director. When making a ruling on completed applications the Executive Director will consider factors that could be competitive disadvantages or prohibit sustainability and participation in sport as well as historical win percentage. Factors considered could include;

- Circumstances where climate or remoteness significantly affects the length of the season and the number of inter-school events;
- Circumstances where schools are either initiating a new program or reactivating one after having been out of competition for a period of time;
- Extenuating circumstances at the discretion of the Executive Director.

633.1 Applications for tiering classification changes are not intended for teams to increase likelihood for a provincial berth, but to encourage the sustainability and longevity of developing teams during league play competition. Executive Director Rulings are only valid for the current school year.

634.0 SPORT TIERING LEVELS

Sport Tiering levels are used to determine the number of tiers (A, AA, AAA, AAAA) allocated to each official activity, and are decided based on two (2) main criteria;

634.1 The required number of teams participating in the respective sport

634.2 The number of BCSS Zones with eligible registered teams

635.0 Should a sport fall below the minimum number of actively participating schools as outline in the chart below for three (3) consecutive years, the sport tiering level will be reviewed and reclassified as an invitational event by the Tiering and Sport Evaluation Committee.

635.1 Sport Level Classifications

SPORT LEVEL	REQUIRED # OF SCHOOLS	# OF ZONES WITH TEAMS	# OF TIERS
IV	200	8	4
III	150	8	3
II	100	7	2
I	50	6	1

636.0 SPORT SPECIFIC TIERING CYCLES

Boys Basketball Tiering will be reviewed biennially (every second year) with the second year of the current cycle in the 2021-2022 school year. During the tiering process for Boys Basketball, BCSS will ensure all 4 tiers (A,AA,AAA,AAAA) will have equal schools with the exception of A which will be 3 schools larger to account for folded teams. When establishing tiering BCSS will use the following structure:

636.1 To determine sport tiering classifications, member school population numbers will be calculated using the previous year's grade ten (10) boys, grade eleven (11) boys, and Secondary Ungraded (SU) boys numbers as submitted September 30th to the Ministry of Education on the 1701 report.

636.2 Prior to the release of the Boys Basketball tiering, schools with active boys basketball teams will be given the opportunity to submit a Boys Basketball Play-up form to the BCSS office. This form will be sent out to Athletic Directors 1 week after the provincial championship, schools will have 2 weeks to complete and submit the completed form to the BCSS office indicating if they wish to play-up from their current tier.

636.3 In order to maintain equal tier sizing, if a team moves to a higher tier, the bottom school in that tier, as well as the tiers below will be moved down to a lower tier.

*** Ex. If a school on the AA tier list moves up to the AAA tier, the school at the bottom of the 3A tier will be moved down to the 2A tier which would subsequently bump the team at the bottom of the AA list down to the A tier***

636.3 Once the two week opportunity to play up has concluded, the finalized Boys Basketball Tiering List will be sent out to all schools. This list is final, and will not have any changes until the next tiering cycle.

667.0 SPORT TIERING CLASSIFICATIONS

Aquatics (Coed)
AAA - 421 or more students in grades 11 and 12 AA - 126-420 students in grades 11 and 12 A - 125 or fewer students in grades 11 and 12
Basketball (Boys)
AAAA - 277 or more boys in grades 11 and 12 AAA - 188-276 boys in grades 11 and 12 AA - 67-187 boys in grades 11 and 12 A - 66 or fewer boys in grades 11 and 12
Basketball (Girls)
AAAA - 263 or more girls in grades 11 and 12 AAA - 163-262 girls in grades 11 and 12 AA - 79-162 girls in grades 11 and 12 A - 78 or fewer girls in grades 11 and 12
Field Hockey (Girls)
AAA - 251 or more girls in grades 11 and 12 AA - 250 or fewer girls in grades 11 and 12
Football (Boys)
AAA - 275 or more boys in grades 11 and 12 AA - 274 or fewer boys in grades 11 and 12
Golf (Open)
AAA - 361 or more students in grades 11 and 12 AA - 161-360 students in grades 11 and 12 A - 160 or fewer students in grades 11 and 12
Rugby (Boys)
AAA - 276 or more boys in grades 11 and 12 AA - 275 or fewer boys in grades 11 and 12
Soccer (Boys)
AAA - 226 or more boys in grades 11 and 12 AA - 81-225 boys in grades 11 and 12 A - 80 or fewer boys in grades 11 and 12
Soccer (Girls)
AAA - 226 or more girls in grades 11 and 12 AA - 81-225 girls in grades 11 and 12 A - 80 or fewer girls in grades 11 and 12
Tennis (Coed)
AAA - 501 or more students in grades 11 and 12 AA - 500 or fewer students in grades 11 and 12
Track and Field (Boys and Girls)
AAA - 401 or more students in grades 11 and 12 AA - 400 or fewer students in grades 11 and 12
Ultimate (Coed)
AAA - 301 or more students in grades 11 and 12 AA - 300 or fewer students in grades 11 and 12
Volleyball (Boys)
AAA - 226 or more boys in grades 11 and 12 AA - 81-225 boys in grades 11 and 12 A - 80 or fewer boys in grades 11 and 12
Volleyball (Girls)
AAAA - 251 or more girls in grades 11 and 12 AAA - 161-250 girls in grades 11 and 12 AA - 66-160 girls in grades 11 and 12 A - 65 or fewer girls in grades 11 and 12

640.0 SANCTIONING

The intent of sanctioning is to ensure school teams, playing under similar conditions and rules structures are competing fairly against one another, within the spirit and intent of interscholastic athletics. Any competition hosted by and contested between two BCSS member schools, in a recognized activity, during the season of play, is automatically sanctioned. Events that are held out of province, have out of province team(s) participating, or are hosted by a non-member institution, are required to obtain sanctioning prior to the event.

641.0 To ensure that competition is conducted and/or approved by secondary school authorities and that competition is equitable and fair, sanctioning policies have been developed by all provincial school sport associations in Canada and state associations in the U.S.A. Sanctioning assures that competition is being conducted in the best interests of the schools concerned. The competition must be conducted by an educational institution or subject to the controls of school authorities. The following procedures must be used for sanctioning of competition involving schools from outside the province, member schools travelling to competition outside the province, and non-member or third part institution hosting high school events.

642.0 DETERMINING THE HOST

The event host is determined by BCSS and considers the following factors; recipient of entry fees, location of event, and management of the draw and/or tournament operations.

643.0 MEMBER SCHOOLS HOSTING COMPETITION WITH PARTICIPANTS FROM OUTSIDE BC

- 643.1 Any member schools hosting team(s) from out of province must obtain sanctioning from BCSS by submitting the appropriate form.
- 643.2 All hosting application forms must be submitted to BCSS no later than thirty (30) days prior to the start of the event.
- 643.3 All out of province schools must be listed on the form. The host may be subject to fines if participation from out of province teams not listed.
- 643.4 Upon receipt of the appropriate form BCSS will;
- Ensure that the competition is being conducted within BCSS rules and regulations and is in the best interest of the schools concerned;
 - Complete and forward endorsement forms to the appropriate association(s) of the schools involved.
- 643.5 BCSS and Alberta Schools Athletic Association have endorsed a blanket sanctioning policy for member schools situated near the Alberta-BC border as posted on the BCSS website.
- 643.6 Competitions involving schools from three (3) or more different states must also receive sanctioning from the National Federation of State High School Associations (NHFS), and may be subject to an additional processing fee.

644.0 NON-MEMBER OR THIRD PARTY HOSTING

- 644.1 Any non-member or third-party institution (colleges, universities, organizations, companies or individuals) hosting a competition with BCSS member schools must obtain sanctioning from BCSS by submitting the appropriate form.
- 644.1.1 BCSS will charge a sanctioning fee of 3% of total BCSS team/participant registration to the host
- 644.1.2 Any BCSS member school not listed on the form will not be able to participate.
- 644.1.3 If non-school (club or community) teams and BCSS member school teams are participating at the same tournament they must compete in separate categories/divisions/events etc. In the event of individual sports, high school athletes belonging to club teams should compete only as a member of their High School and only compete against High School athletes.
- 644.2 All hosting application forms must be submitted to BCSS no later than thirty (30) days prior to the start of the event.
- 642.1.4 Upon receipt of the appropriate form BCSS will;
- Ensure that the competition is being conducted within BCSS rules and regulations and is in the best interest of the schools concerned;
 - BCSS will provide third party host with confirmation of sanctioning once the appropriate endorsements from required provincial and state associations have been secured and list the tournament on the BCSS website as a 'sanctioned event.'

645.0**TRAVELLING TO COMPETITION OUTSIDE BC**

- 645.1 Any member school travelling to competition (tournament, meet, event or exhibition) in Canada or the United States must obtain sanctioning from BCSS by submitting the appropriate form.
- 645.2 Any member schools travelling on international tours, and/or cultural exchanges outside the United States or Canada must obtain sanctioning from BCSS by submitting the appropriate form. Member schools wishing to travel internationally for competition should check with BCSS prior to finalizing travel arrangements.
- 645.2.1 The expectation is that member schools travelling internationally will participate in competition only against school teams.
- 645.2.2 If travelling internationally to an area that does not have high school sport, Member Schools can apply to BCSS for an exemption to this policy at the discretion of the Executive Director.
- 645.2.3 The exemption will be evaluated by the Executive Director and a decision will be made based on the age of student-athletes, sport and location in question.
- 645.3 All travel sanctioning applications must be submitted to BCSS no later than thirty days (30) prior to the start of the event.
- 645.4 Upon receipt of the appropriate form, BCSS will:
- Ensure that competition is being conducted within BCSS rules and regulations and is in the best interests of the schools concerned,
 - Complete and forward endorsement forms to the appropriate association(s) of schools involved

646.0 SANCTIONING PENALTIES

- 646.1 **HOSTING UNSANCTIONED EVENTS**
Member schools or non-member/third party institutions not completing the appropriate forms, or intentionally providing inaccurate information will be fined a minimum of \$500.00 per instance.
- 646.2 **LATE SANCTIONING FORM SUBMISSION**
Member schools or Non-member/third party institutions not completing the appropriate form(s) in accordance with 643.2, 644.2, and 645.3 will be fined a minimum of \$200.00 per instance.
- 646.3 **MEMBER SCHOOLS PARTICIPATING IN UNSANCTIONED COMPETITION**
Any Member School that participates in unsanctioned competition will be penalized. Penalties for competing in unsanctioned competition may include, but are not limited to, reduction in the allowed number of playing days, monetary fines, forfeiture of games, suspension of coach, and/or disqualification from post-season play. Review of the circumstances and penalties remain at the discretion of the Executive Director.

647.0 FUNDRAISING/PROMOTIONAL GAMES

Despite 620.0, each team at a member school is permitted to play one (1) fundraising or promotional game per school year, whether the game occurs during the applicable season of play or not.

- 643.1 A member school shall not participate in a fundraising or promotional game if the opposing team contains one (1) or more student-athletes from another member school.
- 643.2 The member school must report the following details to the Executive Director, by no later than two (2) school days after the game:
- The member school team;
 - The opposing team; and
 - The date and location of the game.

648.0 TOURING/HOSTING OUT-OF-SEASON

Despite 620.0, each team at a member school may apply to BCSS on the appropriate form to:

- 648.1 Travel on one (1) tour outside of the applicable season of play; OR
- 648.2 Host one (1) out of province school team for competition outside of the applicable season of play.

649.0 A member school touring or hosting under 644.0 shall comply with all sanctioning requirements in BCSS Policies.

650.0 APPROVED TYPES OF COMPETITION

The following policies define the types of competition approved by BC School Sports:

650.1 EXHIBITION

Exhibition (also known as scrimmage, friendly or preparation) play consists of any unofficial games, events or matches that are played between two (2) school teams where the results have no impact on team standings, ranking systems or tournament seeding.

650.2 INVITATIONAL EVENTS

Invitational events include tournaments, contests, series or tests in which only the teams or student-athletes participating have been invited by the host, and where no qualification process occurs.

650.3 LEAGUE PLAY

League play falls under the jurisdiction of the local athletic association, and involves any play coordinated at the local association or district level until the conclusion of regular season play.

650.4 POST SEASON

Post season (playoffs) include any inter-school competition after the conclusion of league or regular season play, and on the pathway to provincial championships. This includes local, zone and provincial championships

**700: ZONE AND PROVINCIAL
CHAMPIONSHIPS**

710.0 BCSS ZONE CHAMPIONSHIPS

711.0 BCSS ZONE CHAMPIONSHIPS

Zones are responsible for hosting Zone Championships for the purpose of qualifying teams for Provincial Championships. All BCSS Zones shall determine the structure and process for their zone championship which must be led, planned, and executed in a manner consistent with the following objectives;

711.1 To establish a systematic, transparent, equitable and objective qualification process into the Provincial Championships

711.2 To recognize schools from across the province as the best teams from their zone

711.3 To create an opportunity to celebrate BC School Sports, our zones, local associations, member schools and student athletes, and the positive effects of education-based athletics.

711.4 To host Zones within a timeline that allows for the submission of qualified teams or individuals for provincials to BCSS before the appropriate date

712.0 Only BCSS member schools may participate in qualification play leading up to a BCSS championship, and in championship play. Only one (1) team from a member school may enter post season competition that leads up to a championship.

720.0 BCSS PROVINCIAL CHAMPIONSHIPS

721.0 BCSS PROVINCIAL CHAMPIONSHIP

A BCSS Provincial Championship is an interscholastic event, tournament or meet organized by BCSS, and has the following characteristics:

721.1 Are for school teams and/or individuals participating at the senior level of competition. Senior competition is defined as the highest level of school competition in British Columbia, and is open to student-athletes up to and including the fifth (5th) year of eligibility.

721.2 Teams/Individuals participating at a BCSS championship must have qualified for the championship through a competitive qualification process as determined by the applicable BCSS zone.

721.2.1 Recognizing the limited number of teams and the ability to only safely play one football game per week, BCSS will run a provincial football league and qualification process.

721.3 The championship must be organized and conducted under the Bylaws and Policies approved by the legislative assembly.

722.0 CHAMPIONSHIP RANKING AND TOURNAMENT FORMAT

722.1 All BCSS championships will follow the tournament format set out and approved by the Legislative Assembly as outlined in section _____

722.2 Seeding for championships will be finalized by BCSS and the Tournament Committee with guidance from the sport specific provincial ranking committee where applicable.

723.0 BERTHING FOR PROVINCIAL CHAMPIONSHIPS**723.1 ALLOCATION OF BERTHS**

Berths into a provincial championship are allocated by approval of the Legislative Assembly. Berths must be allocated to a BCSS zone consistent with Section 15 of the Bylaws. Berths will not be awarded to a specific athletic association, subgroup, or school, with the exception of a berth being allocated to the championship host school where applicable. BCSS Provincial Championship berthing can be found in the BCSS Sport Specific Policies.

723.2 QUALIFICATION PROCESS

Each BCSS zone, shall have at least one berth into each provincial championship through a zone championship event. Berths unable to be filled by zones will be allocated in accordance with the applicable BCSS policy.

724.0 CHAMPIONSHIP ENTRY AND/OR PARTICIPATION FEES

Entry fees will be established by BCSS in conjunction with the appropriate Championship Host Committee. When establishing entry fees the goal is to ensure costs of BCSS championships are as low as possible.

724.1 The entry fee for teams/individuals competing in a BCSS provincial championship are intended to cover the expenses of:

- Facility rental and equipment;
- Event officials/judges; and
- Medical coverage at the tournament;
- Webcasting where applicable

724.2 OTHER RELATED CHARGES

Provincial Championship items such as championship apparel, souvenir programs, etc. cannot be mandatory elements to be paid by participants.

725.0 PROVINCIAL CHAMPIONSHIPS SOCIAL EVENTS FOR STUDENT-ATHLETES

Social events such as a banquet or hospitality function may be offered for the Provincial Championship participants. The charge to student-athletes and coaches or competing schools for social events cannot be mandatory, however schools are strongly encouraged to participate as it enriches the championship experience for student-athletes.

726.0 PROVINCIAL CHAMPIONSHIP CALENDAR

The Provincial Championship Calendar set by the Legislative Assembly 3 years in advance is created with the following objectives;

- 726.1 To minimize disruption to instructional time, cost and strain on human resources.
- 726.2 To recognize the number of school days involved
- 726.3 To ensure facility needs for specific events.
- 726.4 To ensure all Official BCSS Championships end on a Saturday unless otherwise stated on the calendar

730.0 ESTABLISHING A PROVINCIAL CHAMPIONSHIP HOST

731.0 DETERMINING A PROVINCIAL CHAMPIONSHIP HOST

The Legislative Assembly determines whether championships are hosted by a member school or hosted at a centralized location by a Championship Host Committee with guidance from BCSS staff.

- 731.1 MEMBER SCHOOL HOSTED CHAMPIONSHIPS- Any BCSS member school may bid to host a BCSS Provincial Championship at their school in a tier in which they compete in the applicable sport. By hosting a championship, the host school is guaranteed a host berth into the championship but are still required to pay the championship entry fee.
- 731.2 CENTRALIZED CHAMPIONSHIPS – The Legislative Assembly will determine the venue based on sport specific needs. The BCSS staff will work to establish a championship host committee for each BCSS Coordinated Championship. There will be no host school, or host berth applicable with these championships.

Note: Any championship host/venue agreements for the 2021-2022 season will be honoured during this transition

731.3 CHAMPIONSHIP BID AVAILABILITY;

The following championships are school hosted championships and are open for bid by member schools;

SCHOOL HOSTED CHAMPIONSHIPS
A Boys Soccer
AA Field Hockey
AAA Field Hockey
A Boys Volleyball
A Girls Volleyball
AA Girls Volleyball
AAA Girls Volleyball
AAAA Girls Volleyball
Gymnastics
Curling
A Girls Basketball
Badminton
Mountain Biking
A Girls Soccer
AA Girls Soccer
AAA Girls Soccer
A Golf

AA Golf
AAA Golf
AA Tennis
AAA Tennis

732.0 EXPECTATIONS OF A HOST

All BCSS hosts are expected to uphold the following standards while planning, leading, and executing BCSS Championships;

- 732.1 Provide safe facilities and equipment for all participants (student-athletes, coaches, officials, volunteers, and spectators) of championship events.
- 732.2 Uphold all BCSS Codes of Ethics.
- 732.3 Actively contribute to enhancing the BCSS Championship brand.
- 732.4 Follow the guidelines of the BCSS Championship Hosting Manual

733.0 BID PROCESS

Based on the Provincial Championships available for bid in section 731.3, member schools wishing to host are required to submit a bid to the Legislative Assembly.

- 733.1 Bid Requirements:
The following information must be included in the bid to be considered by the Legislative Assembly. The Legislative Assembly may request further information on any submission.
 - 733.1.1 General tournament logistics including but not limited to event venue specifics, spectator capacity, number of playing areas, and available changing facilities
 - 733.1.2 Identify potential tournament committee members and the Tournament Director
 - 733.1.3 Proposed budget for the event with anticipated expenses/revenues
 - 733.1.4 Local accommodation available and transportation options for travelling teams
 - 733.1.5 Administrator signature of endorsement, acknowledgement and understanding of the BCSS Championship Hosting Manual and Host Expectations
- 733.2 As per the schedule below, the Legislative Assembly will evaluate all submitted bids at least 18 months prior to the date of the championship
- 733.3 Any school hosted championships without a host after the appropriate general meeting will be filled by approval of the Board of Directors

734.0 BID APPLICATION IMPORTANT DATES

- 734.1 Bid applications for the FALL and WINTER Season of Play Championships will be reviewed and voted on by the Legislative Assembly at the Annual General Meeting two years prior to the championship dates, approximately 18 months before the championships.
- 734.2 Bid applications for the SPRING Season of Play Championships will be reviewed and voted on by the Legislative Assembly at the Fall Planning Meeting the year prior to the championship dates, approximately 18 months prior to the championships

MEETING DATE	SEASON OF PLAY BIDS BEING EVALUATED
Fall Planning Meeting 2021	Spring Championships 2023
Spring Annual General Meeting 2022	Fall/Winter Championships 2023
Fall Planning Meeting 2022	Spring Championships 2024
Spring Annual General Meeting 2023	Fall/Winter Championships 2024
Fall Planning Meeting 2023	Spring Championships 2025
Spring Annual General Meeting 2024	Fall Championships 2025
Fall Planning Meeting 2024	Spring Championships 2026
Spring Annual General Meeting 2025	Fall/Winter Championships 2026
Fall Planning Meeting 2025	Spring Championships 2027

- 734.3 All Bid applications must be submitted to the BCSS office 4 weeks prior to the appropriate meeting.

800: ELIGIBILITY & REGISTRATION

810.0 STUDENT-ATHLETE & TEAM ELIGIBILITY

811.0 BCSS recognizes the right of all student-athletes to choose which school they attend and which subjects they study. BCSS, however, is charged with the responsibility of drafting, implementing and enforcing rules on eligibility for those student-athletes who seek the privilege of participating in interscholastic competition. The overriding purpose of these rules is to ensure fair and equitable competition for all student-athletes participating in BCSS activity. Individual student-athletes must meet the applicable eligibility requirements of BCSS and any applicable sport commission gender-based equity rule to participate in BCSS activity, and be listed on the appropriate STARS roster to be eligible for competition.

812.0 A member school team is defined as any one (1) student-athlete or group of student-athletes who are representing the member school in interscholastic sport activity, and are supervised by a school district approved coach/sponsor and under the authority of the school administrator. All member school sport teams must be properly registered in STARS by the published deadline dates in order to compete in BCSS competition. Individual student-athletes must be registered and approved in STARS as part of their eligibility requirements. Additionally, student-athletes must be registered on the appropriate STARS team roster.

812.1 The school that is being represented by a team must be a member school of BCSS as per 110.0

812.2 A member school team is prohibited to compete against non-member school teams, club teams and community teams in a BCSS activity, with the exception of Gr. 8 school teams where non-member BCSS middle school leagues exist. This exemption is only valid for league contests and does not apply to tournaments or other exhibition play.

813.0 STUDENT-ATHLETES REGISTERED AT AND COMPETING FOR A MEMBER SCHOOL

A student-athlete can only play for the member school at which they are registered. Student-athletes must be in grades eight (8) to twelve (12) at a BCSS member school in order to compete in any BCSS competition.

813.1 An individual student-athlete is only eligible to compete in one (1) thirteen (13) week sanctioned season of play per sport in each school year.

814.0 STUDENT-ATHLETES REGISTERED AT MORE THAN ONE (1) MEMBER SCHOOL

If a student-athlete is registered at two (2) schools, the student-athlete may only participate in BCSS activities for the member school at which the student-athlete has the largest percentage of the credit load.

814.1 If the credit load at the two (2) member schools is equal, the school at which the student-athlete was first registered at in a BCSS activity would be considered their home school.

814.2 If, at any time after the student-athlete's home school has been established, the member school at which the student-athlete is enrolled in the majority of his/her credit load changes, the school which now has the majority of course load, must establish eligibility by meeting the conditions outlined in 600.0.

815.0 FULL-TIME STUDENT-ATHLETE STATUS

A student athlete must be enrolled in and attending a minimum of a sixty-two and a half percent (62.5%) course load. A one hundred percent (100%) course load is defined as thirty two (32) credits or eight (8) standard courses.

815.1 LINEAR SCHOOL SYSTEM - Student-athletes must be enrolled in and attending a minimum of five (5) full time courses (20 credits) within the school year to be considered eligible.

815.2 SEMESTER SCHOOL SYSTEM - Student-athletes must be enrolled in and attending a minimum of two (2) full time courses (8 credits) in both semesters and a minimum of five (5) courses total within the school year to be considered eligible.

815.2.1 A student-athlete who completes his/her school graduation requirements mid-year (January) and does not continue to enroll in courses, must have been awarded credit in a minimum of three (3) courses in the first semester to remain eligible for the conclusion of the winter season of play. The student-athlete is ineligible to begin a new season of play (Spring).

815.2.2 Student-athletes who complete graduation requirements during the current school year and continue to take courses, will remain eligible, should they continue to meet all other eligibility requirements.

816.0 STUDENT-ATHLETE AGE & COMPETITIVE LEVELS

To be age-eligible to compete in competition of a BCSS activity student-athletes must meet both the age and grade eight (8) entry dates as outlined below:

Competition Level	Age	Grade 8 Entry Date
Grade 11 & 12 (Senior)	Student-athlete must be under nineteen (19) years of age as of December 31 of the current school year	2016 or later
Grade 10 (Junior)	Student-athlete must be under seventeen (17) years of age as of December 31 of the current school year	2018 or later
Grade 9 (Juvenile)	Student-athlete must be under sixteen (16) years of age as of December 31 of the current school year	2019 or later
Grade 8 (Bantam)	Student-athlete must be under fifteen (15) years of age as of December 31 of the current school year	Must be 2020

817.0 GRADE SEVEN (7) STUDENT-ATHLETE COMPETITION

Grade seven (7) student-athletes are not automatically allowed to participate in competition of a BCSS activity. A grade seven (7) eligibility application can be made to the Eligibility Officer for an exemption to allow a grade seven (7) student-athlete to play for a grade eight (8) or bantam team where the member school would not otherwise be able to field a team due to insufficient numbers.

- 817.1 The Eligibility Officer will review the grade seven (7) eligibility application to ensure that all of the following conditions are met:
 - 817.1.1 Grade seven (7) student-athletes must be registered as a student at the school applying for the exemption;
 - 817.1.2 Grade seven (7) student-athletes can only participate on a grade eight (8) or bantam team sports;
 - 817.1.3 Grade seven (7) student-athletes cannot participate in the individual sports of aquatics, cross country, gymnastics, mountain biking, skiing/snowboarding, track and field, or wrestling;
 - 817.1.4 Grade eight (8) or bantam student-athletes cannot be registered on the member school's more senior team for the requested team sport;
 - 817.1.5 Grade seven (7) student-athletes being allowed to participate in a grade eight (8) or bantam level team is to allow a member school to field a grade eight (8) or bantam level team which otherwise would not happen due to an insufficient number of grade (8) student-athletes wanting to participate;
 - 817.1.6 The number of grade seven (7) student-athletes on the given team must not exceed the number of grade eight (8) or bantam level student-athletes; and
 - 817.1.7 The maximum number of student-athletes on the given team must not exceed the BCSS minimum numbers required to field the team (see 413.0).
 - 817.1.8 Where all conditions outlined in 517.1.1 through 517.1.6 are met, schools in category 2,3,4 (as per 161.0) are not subject to 517.1.7 in the sports of basketball and volleyball. However, the roster size may not exceed twelve (12) if using grade sevens (7).
- 817.2 Application and conditional acceptance of grade seven (7) student-athletes may be terminated by the Eligibility Officer if the 517.1 conditions are not met.
- 817.3 Grade seven (7) student-athletes who play on a grade eight (8) or bantam team will begin their five (5) years of eligibility on the date they enter grade eight (8).
- 817.4 The Eligibility Officer's decision is final and conclusive and shall not be appealed or reviewed in any manner.

818.0 STUDENT-ATHLETE PLAYING UP & MOVEMENT BETWEEN TEAMS

- 818.1 **INDIVIDUAL STUDENT-ATHLETES PLAYING UP TO A MORE SENIOR SCHOOL'S TEAM**

Middle/Junior member school athletes whose feeder school (senior school) has a Membership Category of four (4) or lower can apply to "play up" to the senior member school that they would normally attend if, by the roster registration deadline (see 532.3), they have approval of both member schools' administrators, athletic directors, students, and parents(s) or legal guardian(s). The middle/junior school must be a member in good standing. The local athletic association, the district superintendent, and BCSS must be notified by using the appropriate form. Senior member schools must not register these student-athletes in STARS as an enrollee of their school. BCSS will place the middle/junior school student-athletes on the senior member schools STARS team roster when the form is received and approved. Any student-athletes not properly registered will be deemed ineligible.

 - 818.1.1 Member schools with Football and/or Rugby Programs may allow grade nine (9) student-athletes at their feeder school (middle school) to play up to the more senior school Junior Varsity (JV) team. Grade nine (9) student-athletes at a feeder school (middle school) may not play up to the senior school varsity team.
 - 818.1.2 **LIMITS TO PLAYING/MOVING UP**

Student-athletes attending a middle school or junior secondary school cannot play or move up in the sports of aquatics, cross country, gymnastics, mountain biking, skiing/snowboarding, track and field, or wrestling as the minimum number to form a school team in these sports are one (1) athlete.
 - 818.1.3 The exemption to this rule is football whereby student-athletes registered on a lower level team may play for the higher level team at the same time without restriction during playoffs.
- 818.2 **MOVEMENT BETWEEN TEAMS**

A registered student-athlete may play up to a more senior team during league play without restriction on the number of days. Once the player has participated in playoffs, any competition following the conclusion of the regular season. The player must stay up with the more senior team and a Moving Player to a Higher Age-Group Team form must be completed in STARS. Once approved, the student will be registered with the more senior team for the remainder of that season.

- 818.2.1 If a school registers two (2) or more teams in the same age group in the same sport, there will not be any movement between those two (2) teams for competition.
- 818.2.2 Football is exempt from 518.2 Any registered student-athlete within the Football Commission may play up to a more senior team during playoffs without restriction - including playing for both teams during the playoffs, provided that the student-athlete playing up on the more senior team is registered on a lower level team. No student-athlete registered on a senior team with BCSS may play down at a lower level.

818.3 **INDIVIDUAL STUDENT-ATHLETES MOVING UP AT THE END OF THEIR AGE GROUP SEASON**
 A student-athlete who is otherwise eligible and is registered on one (1) of the school teams in the same sport, or is eligible as per 518.1, may join the more senior team in that sport after the completion of the lower age level team's league competition and playoff schedule. The student-athlete must be added to the appropriate STARS roster for the more senior team before competing. The addition of the student-athlete is made by notification in STARS to the BCSS office with the student-athletes name, the name of the team on which they were originally registered and the team they would like to move up to (submission in STARS - Moving Up Form).

819.0 NUMBER OF YEARS OF ELIGIBILITY - FIVE (5) YEARS

Student-athletes have five (5) consecutive years of BCSS competition eligibility, starting on the entry date into grade eight (8). A year is considered to be the twelve (12) month period between September of one (1) school year and September of the next school year.

819.1 **IF A STUDENT-ATHLETE DOESN'T PARTICIPATE**
 If a student-athlete chooses not to participate during one (1) or more years of the five (5) year period, or is not on a team roster during one (1) or more years of the five (5) year period, or leaves school (withdraws) for a time period during the five (5) year eligibility time period, that time period will still count toward the five (5) years of eligibility.

819.2 **UNGRADED STUDENT-ATHLETES**
 For ungraded student-athletes in schools where it is difficult to determine when a student-athlete entered grade eight (8) (e.g. middle school, K-10, K-12 schools), the student-athlete will be considered to be a grade eight (8) student-athlete in the school year commencing in September of the calendar year in which the student-athlete becomes thirteen (13) years of age.

819.3 **EXTENSION OF FIVE (5) YEARS OF ELIGIBILITY DUE TO LOST SCHOOL FOR MEDICAL REASONS**
 If a significant portion of a school year is lost due to illness or accident, the member school may submit an eligibility application on the student-athlete's behalf to have up to one (1) year of eligibility restored (See 642.0). Medical documentation must show that the loss of an academic year due to medical reasons resulted in the student-athlete having to repeat a grade and prevented the standard five (5) year progression through school. The eligibility time restored will not include any seasons of play in which the student-athlete had been enrolled in school during the academic school year in question. The eligibility application must include medical documentation, academic records and absentee records for the school(s). No student-athlete will be granted a sixth (6th) year of eligibility in any sport he/she has already participated in for part or all of five (5) seasons. Nor will that student-athlete be granted a sixth (6th) year of eligibility if they have participated in any part of both a fourth (4th) and fifth (5th) year of eligibility.

819.4 **ELIGIBILITY FOR FAMILIES MOVING TO BRITISH COLUMBIA**
 A student-athlete whose family is coming into British Columbia from another province or another country is eligible for five (5) years from their date of entry into grade eight (8) or the grade eight (8) equivalent in their previous place(s) of residence. If documentation is unavailable, the student's birth year will be used for the students date of entry into grade eight (8) as consistent with 519.2 ungraded student-athletes.

819.5 **RETURNING EXCHANGE STUDENT-ATHLETE**
 A BC student-athlete who is returning to British Columbia after conclusion of a one (1) year or less outgoing student exchange program, and who has concluded their eligibility calendar in accordance with 519.0, may have up to one (1) year of eligibility restored only if all of the following conditions are met:

- The student-athlete has participated in a recognized exchange program;
- The student-athlete is returning to the same BCSS member school that they attended prior to leaving on the exchange program;
- The student-athlete does not participate in any BCSS competition in BCSS approved sports in which the student-athlete participated in inter-school and/or club competition while on the exchange;
- The student-athlete meets all other eligibility requirements; and
- A letter from the administrator confirming compliance with the conditions outlined in 519.5 is required.

820.0 RESIDENCY REQUIREMENT

The residency rule is intended to create an equitable environment in which its member schools can compete, and at the same time prevent those abuses that taint the goals on inter-scholastic athletics. Primarily the residency rule is intended to prevent athletic recruiting, prevent students from choosing schools for athletic reasons, and to promote families as the best environment for students to live while attending school. Deterring students from avoiding imposed discipline, protecting school programs by discouraging athletic transfers and protecting the opportunities for bona fide resident students to participate are also reasons for the residence rule.

- 820.1 Student-Athletes Must Fulfill One of the Following Residency Requirements
- 820.1.1 Reside with parent(s) in BC;
 - 820.1.2 Reside with a legal guardian in BC. Guardianship must have been in place for twelve (12) months prior to the period for which eligibility is sought.
 - 820.1.3 Must be a 'Ward of the Province of BC' and assigned to an individual or family by the Ministry of Children and Family Development.
 - 820.1.4 Must be attending a BC member school as a 'residing full-time boarding student' – this must have been in place for twelve (12) months prior to the period for which eligibility is sought; During the twelve (12) month waiting period, the student-athlete may play subject to 600.0; or
 - 820.1.5 Must be attending a BCSS member school as an international student or exchange student and be recognized by the District Board or Independent School office as such – student-athletes must reside in BC and attend the member school for a period of five (5) months of be eligible to participate in BCSS competition.
- 820.2 Any student-athlete who does not meet the residency requirements is fully ineligible for a period of twelve (12) months from the date they seek eligibility. At the completion of the twelve (12) months the student-athlete will become eligible if they meet the following:
- 820.2.1 The student-athlete maintains the same address and living situation throughout the twelve (12) months; and
 - 820.2.2 The student-athlete must meet all other eligibility requirements as per the entirety of the Competitive Rules and Regulations.

821.0 STUDENT-ATHLETE GENDER

Female student-athletes may only play on a team designated as a girl's sport, and male student-athletes may only play on a team designated as a boy's sport. Both female and male student-athletes may compete on a team designated as a coed sport, in accordance with the sport-specific roster allocations.

- 821.1 Notwithstanding 521.0 a student-athlete may be permitted to participate in a sex-segregated sport inconsistent with his/her sex in the following circumstances:
- 821.1.1 A female student-athlete may play on a boys' team if her school will not offer a girls' team in that sport (in a recognized BCSS activity or not) at the appropriate age level during the same school year. A letter from the administrator confirming a girls' team will not be offered must be sent into the BCSS office. If a female student-athlete plays on the appropriate age level boys' team, she may not play on the more senior girls' team in a different season of play during the same school year.
- 821.2 **GENDER IDENTITY** - A student-athlete may participate with the opposite sex in a sex-segregated sport on the basis that doing so would be consistent with his/her gender identity if the student-athlete's application under 521.0 is granted.
- 821.2.1 A student-athlete who does not identify as either binary gender or identifies as, "non-gendered", or "gender neutral", may participate with the sex in which they feel most comfortable.
 - 821.2.2 A student-athlete who identifies as "gender fluid", may participate with the sex they identify with at the time of the season of play if the student-athlete's application under 521.0 is granted. The student-athlete may not switch genders within the season of play. If they wish to identify as the opposite gender in a different season of play, a letter from the school administration must be submitted to the BCSS office.
- 821.3 A student-athlete seeking eligibility pursuant to 521.0 must make an application to the Executive Director.
- 821.3.1 Each application under 521.0 must include the following:
 - 821.3.1.1 A written statement from the student-athlete documenting a student-athlete's gender identification;
 - 821.3.1.2 A written statement from the principal confirming the student-athlete's gender identity.
 - 821.3.2 The Executive Director shall consider the following factors together with any other factors that he/she considers reasonable when making a decision under 521.0:
 - 821.3.2.1 Flexibility, and the student-athlete's privacy, will be prioritized in decision-making;
 - 821.3.2.2 The importance of fair and equitable competition for all students participating in the sport in which the student is applying to participate;

- 821.3.2.3 Existing practices regarding female student-athletes' participation on boys teams, as per 521.0, are to be preserved; and
- 821.3.2.4 An environment where intersex, transitioning and trans-gender students can exist and thrive should be provided.
- 821.3.3 The Executive Director's decision is final and conclusive and shall not be appealed or judicially reviewed.
- 821.3.4 Once a student-athlete has been granted eligibility under 521.0, their eligibility shall be effective for the duration of the student-athlete's school sport career and does not need to be renewed unless the gender identity changes as per 521.2.2
- 821.4 If there is a conflict between 521.1 or 521.2 and a bylaw, rule or similar provision of a sport commission, the bylaw, rule or similar provision prevails.

822.0 DISTRIBUTED LEARNING, AND ALTERNATE SCHOOL STUDENT-ATHLETES

- 822.1 Alternate school student-athletes may compete in BCSS competition provided that:
 - 822.1.1 INDIVIDUAL SPORTS
The student-athlete competes for the school they currently attend (alternate school) in individual sports.
 - 822.1.2 TEAM SPORTS
 - a) The student-athlete competes for their previously established home school; or
 - b) If the student-athlete has not previously established a home school, they must compete for the school in whose catchment area they reside.
- Note: The administrators at both the receiving and alternate/distributed learning school must support the student's involvement on a sports team.

- 822.2 Distributed learning school student-athletes may compete in BCSS competition provided that:
 - 822.2.1 The student-athlete competes for their previously established home school; or
 - 822.2.2 If the student-athlete has not previously established a home school, they must compete for the school in whose catchment area they reside.

Note: A student enrolled at a Home Study, Distributed Learning or Alternate school is not eligible to compete in a relay event within an individual sport, (i.e. track, swimming) for any school other than the school in which they are formally registered as a student with the Ministry of Education.

823.0 INTERNATIONAL STUDENTS

- For International Students (Boarding, Exchange, and International) to become eligible to participate in a BCSS activity, the school Principal or District Office shall verify in writing and submit to the BCSS office that:
- 823.1 The BCSS member school in which the student-athlete first registers and seeks eligibility will become the student-athlete's home school and where their eligibility is tied. Any subsequent transfers from the student-athlete's home school are subject to 600.0 Student-Athlete Transfers.
 - 823.2 International Students' (Boarding, Exchange & International) eligibility and competitive age level will be determined by their birthdate prior to becoming eligible to participate in a BCSS activity, the school Principal or District Office shall verify in writing and submit to the BCSS office that the International Students meet the following:
 - 823.2.1 The acceptance of the student-athlete is based solely on academic criteria;
 - 823.2.2 The student-athlete is enrolled at the receiving school for at least five (5) consecutive months or one (1) semester;
 - 823.2.3 The student-athlete has not graduated from a high school program;
 - 823.2.4 That a student-athlete's participation in extracurricular athletics was not a factor in acceptance to the school;
 - 823.2.5 The student-athletes is not receiving a scholarship, bursary, or financial awards resulting from or relating to student-athlete participation;
 - 823.2.6 The student-athlete is eligible as per all other BCSS eligibility policies, including age and the eligibility calendar.
 - 823.3 In addition to the above, International Students must meet the criteria in one of the following International Student Designations to be deemed eligible for BCSS activity:
 - 823.3.1 EXCHANGE STUDENT ATHLETE
 - a) The Exchange Program is an established and recognized program by either the federal or provincial government;
 - b) The student-athletes transfers into the member school from outside British Columbia and

is not a resident of British Columbia;

823.3.2 BOARDING STUDENT ATHLETE

- a) The student-athlete is registered at a member school as a boarding student and pays tuition according to the published boarding student policy and fee schedule;
- b) The student-athlete resides in a school dormitory;
- c) The student-athlete transfers into BCSS member school from:
 - Outside of Canada: The student-athlete can compete in any BCSS activity; or
 - Inside of Canada: The student-athlete is ineligible for a period of twelve (12) months from the date of transfer to compete in any BCSS activity in any school sport in which he/she was registered for at their previous school in the twelve (12) months prior to the date of transfer. The student-athlete does not become eligible under this category until the member school submits Notification of Transfer from to the Eligibility Officer for review
- d) The student-athlete must pay 100% of the posted rate as published by the district and/or school they are attending. Should a boarding student receive any form of financial aid, scholarship, bursary or any other form of third (3rd) party support, the student must pay a minimum of \$26,000 after any financial support in order to be eligible.

823.3.3 INTERNATIONAL STUDENT ATHLETE

- a) The student-athlete is registered at a member school as an international student and pays tuition to that school district according to the published international student policy and fee schedule;
- b) The student-athlete is placed with a home-stay family, lives with parents or lives with family members who have custodial guardianship over the student-athlete;
- c) The student-athlete transfers into the member school from outside of Canada
- d) The student-athlete must pay 100% of the posted rate as published by the district and/or school they are attending. Should an international student receive any form of financial aid, scholarship, bursary or any other form of third (3rd) party support, the student must pay a minimum of \$26,000 after any financial support in order to be eligible.

830.0 REGISTRATION

831.0 REGISTRATION OF ELIGIBLE STUDENT-ATHLETES

Prior to participating in competition of a BCSS activity, the member school is responsible for ensuring that any:

- 831.1 Student-athletes are eligible as per the entirety of the Competitive Rules and Regulations;
- 831.2 Student-athletes are registered on the applicable STARS roster by published deadlines; and
- 831.3 Student-athletes have not competed in more than one (1) interscholastic season of play per sport each year as defined by BCSS.

832.0 REGISTRATION REQUIREMENTS

832.1 TEAM REGISTRATION DEADLINES

In each season of play, member schools are required to register their teams by meeting the minimum numbers of student-athletes (413.0) in the age levels of competition in which they wish to participate. Member schools will not be penalized for registering a team and then choosing not to participate. Team Registration must be completed in STARS by:

- Fall – October 2, 2019
- Winter – December 18, 2019
- Spring – April 8, 2020

832.2 PENALTIES FOR REGISTRATION AFTER TEAM REGISTRATION DEADLINES

- 832.2.1 In the event a team is not registered in STARS after the Team Registration Deadline (Team and Minimum Numbers) and twenty-one (21) days or more prior to the start of Provincial Championships (inclusive of the first (1st) day of Provincials), the member school will be assessed and automatic fine of \$50 per team. There is a maximum fine of \$300/member school per season of play.
- 832.2.2 In the event a team is not registered in STARS after the Team Registration Deadline and between twenty (20) to eleven (11) days (inclusive) prior to the start of Provincial Championships (inclusive of the first (1st) day of Provincials), the member school will be assessed an automatic fine of \$150 per team (the season maximum does not apply).
- 832.2.3 In the event a team is not registered in STARS after the Team Registration Deadline and ten (10) days or less prior to the start of Provincial Championships (inclusive of the first (1st) day of Provincials), the

member school will be assessed an automatic fine of \$250 per team (the season maximum does not apply).

Missed Team Registration Deadline (Team and Minimum Numbers) *Maximum only applies to 21 days or more prior to Provincial Competition	Days Until Provincials	Fine Amount
	21 Days or more	\$50 per team *Maximum \$300 per season of play
	From 20 - 11 Days	\$150 per team
	10 Days or less	\$250 per team
The first (1 st) day of a provincial championship is counted as day one (1)		

832.3 ROSTER REGISTRATION DEADLINE

In each season of play, member schools may add any additional student-athletes to complete their rosters by the Roster Registration Deadline. This includes, eligible student-athletes who are new to the member school or who are joining the team after the Team Registration Deadline (these student-athletes must not have participated in any competition(s) prior to being registered with BCSS). Roster Registration must be completed in STARS by:

- Fall – TBD
- Winter – TBD
- Spring – TBD

832.4 PENALTIES FOR REGISTRATION AFTER THE ROSTER REGISTRATION DEADLINE

832.4.1 In the event an individual student-athlete is not registered on the STARS team roster after the Roster Registration Deadline and twenty-one (21) days or more prior to the start of Provincial Championships (inclusive of the first (1st) day of Provincials) and is deemed eligible to play by BCSS, the member school will be assessed an automatic fine of \$25.

832.4.2 In the event an individual student-athlete is not registered on the STARS team roster after the Roster Registration Deadline and between twenty (20) to eleven (11) days (inclusive) prior to the start of Provincial Championships (inclusive of the first (1st) day of Provincials) and is deemed eligible to play by BCSS, the member school will be assessed an automatic fine of \$100.

832.4.3 In the event an individual student-athlete is not registered on the STARS team roster after the Roster Registration Deadline and ten (10) days or less prior to the start of Provincial Championships (inclusive of the first (1st) day of Provincials) and is deemed eligible to play by BCSS, the member school will be assessed an automatic fine of \$250.

Missed Roster Registration Deadline	Days Until Provincials	Fine Amount
	21 Days or more	\$25 per student-athlete
	From 20 - 11 Days	\$100 per student-athlete
	10 Days or less	\$250 per student-athlete
The first (1 st) day of a provincial championship is counted as day one (1)		

832.4.4 In extraordinary circumstances, the BCSS Executive Director may in his or her sole discretion, reduce or waive a fine for registration after the roster deadline. The request must be in writing, state the extraordinary circumstances on the late registration and be received within five (5) days of notice of the fine. The request shall be e-mailed to the BCSS office. The decision of the Executive Director is final and binding on all parties.

832.5 PROCEDURES FOR DEALING WITH VIOLATIONS OF THE REGISTRATION POLICIES

832.5.1 THE OFFENDING SCHOOL SELF-REPORTS

A violation of Registration Policies occurs when a student-athlete who otherwise would be eligible competes in interscholastic athletics in a BCSS activity without properly being registered

832.5.2 BCSS Investigation by the Executive Director

- a) Verbal confirmation of the violation with the responding member school; and
- b) The additional information will be added administratively to STARS.

834.1.2 Penalties as per 832.0

- a) Fines will be assessed in accordance with the approved fine schedule in 832.0;
- b) The member school has ten (10) school days to pay the fine (all fines are payable to BCSS); and

- c) If the fine is not paid within ten (10) school days, the team will not be eligible to compete in any BCSS activity until the fine payment is received.

832.6 REGISTRATION VIOLATION DISCOVERED WITHOUT SELF-REPORTING

832.6.1 BCSS Investigation by the Executive Director

- a) Verbal confirmation of the violation with the responding member school;
- b) Written "cease and desist" notification stating that the student-athlete and/or team is ineligible and the fine (cc: athletic association and sport commission); and
- c) The student-athlete and/or team is not eligible to compete in any BCSS activity until all student-athletes are properly registered by BCSS staff in STARS.

832.6.2 Penalties as per 832.0

- a) Fines will be assessed in accordance with the approved fine schedule in 832.0;
- b) The member school has ten (10) school days to pay the fine (all fines payable to BCSS); and
- c) If the fine is not paid within ten (10) school days, the team will not be eligible to compete in any BCSS activity until the fine payment is received.

833.0 PROCEDURES FOR DEALING WITH VIOLATIONS OF ELIGIBILITY POLICIES

833.1 THE OFFENDING SCHOOL SELF-REPORTS

A violation of eligibility policies occurs when a student-athlete who is not eligible to compete in interscholastic athletics in a BCSS activity competes in an activity. It is considered an eligibility infraction if the athlete has competed before being deemed eligible, or in the case of a member school neglecting to initiate the eligibility application process, after the fact is deemed ineligible.

833.1.1 BCSS Investigation by the Executive Director

- a) Verbal confirmation of the violation with the member school;
- b) Written "cease and desist" notification stating the circumstances of ineligibility and the fine (cc: athletic association & sport commission); and
- c) The student-athlete(s) is not eligible unless an Eligibility Application is filed with BCSS and accepted by the Eligibility Officer.

833.1.2 Penalties as per 810.0

- a) Forfeiture of any competition in a BCSS activity in which the ineligible student-athlete(s) has participated;
- b) A \$50 fine per instance, to a maximum of \$200; this is separate from registration fines, should they be necessary;
- c) The member school has ten (10) school days to pay the fine (all fines are payable to BCSS); and
- d) If the fine is not paid within ten (10) school days, the team will not be eligible to compete in any BCSS activity until the fine payment is received.

833.2 ELIGIBILITY VIOLATION DISCOVERED WITHOUT SELF-REPORTING

833.2.1 BCSS Investigation by the Executive Director

- a) Verbal confirmation of the violation with the member school;
- b) Written "cease and desist" notification stating the circumstances of ineligibility and the fine (cc: athletic association & sport commission); and
- c) The student-athlete(s) is not eligible unless an Eligibility Application is filed with BCSS and accepted by the Eligibility Officer.

833.2.2 Penalties as per 810.0

- a) Forfeiture of any competition in a BCSS activity in which the ineligible student-athlete(s) has participated; A \$50 fine per instance, to a maximum of \$500; this is separate from registration fines, should they be necessary;
- b) The member school has ten (10) school days to pay the fine (all fines are payable to BCSS); and
- c) If the fine is not paid within ten (10) school days, the team will not be eligible to compete in any BCSS activity until the fine payment is received.

834.0 FINES COLLECTED FOR VIOLATIONS OF BC SCHOOL SPORTS POLICIES

The money collected by BC School Sports from member schools fined in accordance with the approved disciplinary procedures will be allocated as follows:

- 834.1 Fifty percent (50%) of fine revenue will be directed to operating revenue, specifically targeted to offset the costs of the Eligibility Officer, and the Eligibility Appeals Committee of BC School Sports. Education information and session for coaches, re: the eligibility policies, will also be noted as a possible expenditure item.
- 834.2 Fifty percent (50%) of fine revenue will be directed to a line item established for BC School Sports student-athlete scholarships. The allocation procedures for the scholarship money will be based on recommendations made by the BC School Sports Scholarships Committee, and approved by the Legislative Assembly.

840.0 JOINTLY SPONSORED TEAMS

- 841.0 BCSS believes there is merit in allowing student-athletes to participate in sports programs that are not offered at their home school due to low student enrollments and insufficient numbers. The goal of allowing joint teams is to increase the number of student-athletes that participate in activities.
- 842.0 Two (2) or more member schools may make an application for a Joint Team. If approved student-athletes from those member schools will be able to participate together on the joint team.
- 843.0 Each Application must be made only for team sports and be submitted to the BCSS Office. The application shall:
 - 843.1 Be made with regard to member schools that are located in the same local association;
 - 843.2 Indicate which specific team sport; and
 - 843.3 Include acknowledgment and support from the member schools' administration and local association president.
- 844.0 To maintain the competitive balance and ensure a fair field of play, a joint school team may be approved but the ability for the team to compete in playoffs, zones and championships may be restricted based on the following:
 - 844.1 Member schools who join together and have a combined "category" total of eight (8) or lower as found in Membership Fees (161.0) are eligible to compete in all competition in a BCSS activity (playoffs, zones and provincials);
 - 844.2 Member schools who join together and have a combined "category" total of nine (9) or higher in the Membership Fees Categories (161.0) are not eligible to compete in any post season competition beyond a local or Tier II championship in BCSS activity.
- 845.0 The tiering classification of the joint team will be determined by combining the appropriate tiering numbers of the two (2) or more schools forming the joint team.
- 846.0 A joint team may be terminated by written request, before the expiry of the requested time period in the following cases:
 - 846.1 Closure of one (1) of the participating schools;
 - 846.2 Serious breach of the Bylaws and Policies and Regulations of BCSS of any of the participants; or
 - 846.3 When, it is in the best interests of the student athletes of one (1) or more schools.
- 847.0 The decision is final and conclusive and shall not be appealed or reviewed in any manner.

900: TRANSFERS

910.0 STUDENT-ATHLETE TRANSFERS

A Transfer occurs whenever a student-athlete who is registered at any school (within or outside of BC) transfers and is registered at a different school. A transferring student-athlete who competes on a team at the new school changes the competitive balance that would have been in place prior to the transfer. Consequently, the Legislative Assembly has developed regulations governing the eligibility of student-athletes who transfer schools and wish to participate in interscholastic activities.

911.0 ESTABLISHING A STUDENT-ATHLETE'S HOME SCHOOL

A student-athlete's eligibility is tied to their home school. Any student-athlete transferring schools after their home school is established is subject to the transfer policies. The student-athlete's home school will be established at the member school at which:

- 911.1 A student-athlete plays up to a Senior School (918.1) and is listed on a grade nine, junior or senior team roster or;
- 911.2 The student-athlete registers on the first (1st) day of their second year of eligibility (grade 9).

912.0 STUDENT-ATHLETE TRANSFERRING AFTER HOME SCHOOL IS ESTABLISHED

A student-athlete who transfers after a home school has been established, is ineligible for a period of twelve (12) months from the date of transfer in any BCSS activity in which they competed in the twelve (12) months prior to the date of transfer

- 912.1 A student-athlete who transfers from one school to another school shall not have the right to subsequently transfer to a second school or to subsequently transfer back to their original school and still be eligible for competition in a BCSS activity in the same academic year, without an Eligibility Application.
- 912.2 A member school may only submit one Change of Residence or eligibility application per academic school year per student-athlete.
- 912.3 If a student-athlete transfers due to a member school not offering a sport, the student-athlete is subject to the one-year ineligibility period.
- 912.4 A student-athlete who transfers from their home school to a prep/elite team within or affiliated with a school, and return to their home school, or any other BCSS member school, is considered to have participated in that sport and must seek eligibility as a transfer student. Members of a school prep/elite team are considered to have participated in competition of a BCSS activity.

920.0 TRANSFER EXEMPTIONS

Once a transfer has occurred the student-athlete must gain eligibility to participate in any interscholastic activity. The Legislative Assembly creates the policies governing the eligibility of students transfers and has approved the following exemptions. Transfer exemptions are circumstances taken into consideration when reviewing eligibility, that may allow a student-athlete to gain eligibility without the 12-month ineligibility period.

921.0 STUDENT-ATHLETE ADVANCING TO A MORE SENIOR SCHOOL

- 921.1 A student-athlete advancing from a middle school or junior secondary school after establishing their home school may proceed to the school into which his/her middle school or junior secondary school normally feeds, without any restrictions.
- 921.2 If the student-athlete attended an independent school not offering senior grades, this student-athlete can transfer to a similar independent school offering senior grades, providing the receiving school is the next closest independent school geographically to where the student-athlete lives. The student-athlete can also advance to a public school offering senior grades, as per the normal catchment boundaries of the school district in which the student- athlete resides.

922.0 NEWLY CONSTRUCTED SCHOOLS, SCHOOL DISTRICT RE-ORGANIZATION OR SCHOOL CLOSURE

School districts and/or schools must apply for approval from the BCSS office prior to any student-athlete being eligible. A complete list of those student-athletes impacted must be provided to BCSS with the required information.

923.0 CHANGE IN PRINCIPAL RESIDENCE

The student-athlete has moved with their parent(s) or legal guardian(s), who have changed their principal residence within the previous twelve (12) months. The change of residence must be bona fide. In order for change of residence to be considered bona fide, the following facts must exist:

- The change in residence must not be for the purpose of making the student-athlete eligible for competition in BCSS activity at a member school;
- The original residence must be abandoned as a residence; (i.e. sold, rented or disposed of as a residence, and must not be used as a residence by another member of the family)
- The entire family must make the change and take with them household goods and furniture appropriate to the circumstances;
- The change must be made with the intent that it is permanent;
- The student is ineligible to compete for the receiving school until the actual change of residence has occurred.

- 923.1 If the new principal residence is within the same public school district, the student-athlete may:

- Remain eligible by not transferring schools; or
- Become eligible at the public school into whose catchment boundaries the family has moved.

923.2 If the new principal residence is in a different public school district, the student-athlete may:

- Become eligible at the public school into whose catchment boundaries the family has moved to; or
- Become eligible at the nearest public school that offers a French immersion program if the student-athlete can provide documentation showing they were previously enrolled in a French immersion program at their leaving school; or
- Become eligible at the nearest independent school within the same FISA Member Association Groups, listed below, as the leaving school:
 - Association of Christian School International
 - Associate Member Group
 - Catholic Independent Schools International Society Committee
 - Society of Christian Schools BC
- Become eligible at the nearest independent school to the new residence if the leaving school does not belong to any of the above named FISA Member Association Groups.

Note: Although a school district may allow out-of-catchment registration for a new-to-district student, this does NOT satisfy the criteria to be deemed athletically eligible.

923.3 The student-athlete does not become eligible under this category until the member school submits a School Declaration Form by the parent(s) or legal guardian(s) in a form acceptable to the Eligibility Officer which attests to the details and reason for the change of residence.

Note: The member school may be requested to provide evidence/documentation that the family is residing in a new principle residence and that they have completely moved from the former residence.

924.0 PARENT-TO-PARENT MOVE

The student-athlete moves to reside with the parent with whom they have not been living and is required as a result of the move, to transfer schools. Only two (2) transfers for the purpose of moving from parent to parent are allowed after the first (1st) day of the student-athlete's first (1st) year of eligibility. The move must not be for the purpose of making the student-athlete eligible for competition in a BCSS activity at a member school. The residence of the student shall be that of the parent to whom custody has been awarded by a court of competent jurisdiction. If no custody order has been entered, the residence shall be that of the parent who has custody immediately upon separation. If the move is to a parent:

924.1 Within the same school district, the student-athlete may:

- Remain eligible if the transfer is to the school within the catchment area the receiving parent resides, and the transfer must be to the same kind of school (i.e. independent to independent, public to public, etc.)

924.2 In a different school district, the student-athlete may:

- Be eligible at the public or independent school into whose catchment boundaries the family has moved.

Note: Although a school district may allow out-of-catchment registration for a new-to-district student, this does NOT satisfy the criteria to be deemed athletically eligible.

925.0 MOVE TO A LEGAL GUARDIAN

The student-athlete moves to reside with a legal guardian(s), and as a result is required to transfer schools. Only two (2) transfers for the purpose of moving to a legal guardian(s) are allowed after the first (1st) day of the student-athlete's first (1st) year of eligibility. Legal guardianship must be in place for twelve (12) months prior to when eligibility is sought.

925.1 Eligibility will only be granted for the member school whose catchment area (public school) the guardian(s) resides or the nearest independent school.

925.2 If the student transfers to any other school, the receiving (new) school must submit an Eligibility Application.

925.3 The student-athlete does not become eligible under this category until the member school submits a Change of Residence Form by the parent(s) or legal guardian(s) in a form acceptable to the Eligibility Officer which attests to the details and reason for the change of residence.

926.0 DISTRICT ACADEMIC PROGRAM

A student-athlete who is enrolled in a recognized district academic program as offered by their school district will be eligible to compete in BCSS activity if they meet all BCSS eligibility requirements and will be able to compete as per 831.0. The district academic program must meet the following conditions:

- The district academic program is a coherent program, not just a series of courses; and
- The program is not a work experience program.

- Student - athletes who are enrolled in the district academic program, TREK or the North Vancouver School District (NVSD) Outdoor Education Academy, for a period of one (1) school year and are returning to their original home school immediately upon the conclusion of the program will remain eligible to compete for their home school.
- If the student-athlete wishes to participate in competition in a BCSS activity for the school hosting the TREK or the NVSD Outdoor Education Academy program, the school must file an Eligibility Application in accordance with 943.0. If the student-athlete is approved and participates for the host school in a BCSS activity, they will not be eligible at their original school upon return after the conclusion of the district academic program and will be subject to the transfer rules in 910.0.

927.0 ALTERNATE PROGRAM/SCHOOLS

If an alternate program or school is an offshoot of a particular member school (home school), and is administered by that home school's administrator, the student-athlete in the alternate program is eligible to compete for the home school. If a student-athlete transfers to an alternate program administered by a different principal, the move is considered to be a transfer, and transfer restrictions shall apply (822.0).

928.0 DESIGNATED SPECIAL EDUCATION SCHOOLS

A student-athlete who transfers to a designated Special Education Independent School (as per the Independent School Act and the Ministry of Education) will become eligible at any other designated Special Education Independent School regardless of the catchment area in which they reside. If the student-athlete transfers to a school that is not designated as a Special Education Independent School the student-athlete will be subject to Section 600.0 Student-Athlete Transfers.

929.0 STUDENT-ATHLETE TRANSFERRING FROM ALTERNATE SCHOOL OR DISTRIBUTED LEARNING SCHOOL

A student-athlete who is attending an alternate school in a school district remains eligible upon transfer to the public school in whose catchment area the student-athlete resides; or a student-athlete who is registered at a Ministry of Education distributed learning school remains eligible upon transfer to the public school in whose catchment area the student-athlete resides 522.0).

930.0 SHORT-TERM TRANSFER AND RETURN TO HOME SCHOOL

A student-athlete who transfers to another school for a period of one (1) school year or less, and who has not attempted to gain eligibility in any BCSS activity while attending that school, will regain eligibility upon transferring back to their home school.

931.0 WARD OF THE PROVINCE

The student-athlete who transfers is a Ward of the Province and whose move has been arranged by the province. The receiving school must submit a letter from the school administrator confirming that the placement has been arranged by the ministry having jurisdiction or the government agency responsible for the student-athlete. This letter will include the time of the move, the location of the new residence, and that participation in school sports was not a factor in the placement, and the receiving school must also confirm that the residence of the family or the residence in which the student-athlete has been placed is within the catchment area boundaries of the school.

932.0 STUDENT-ATHLETE TRANSFERS DURING THE MONTH OF SEPTEMBER AS A RESULT OF SCHOOL DISTRICT TRANSFER PROCESS

Per Section 74.1 of the School Act, a board must have a protocol in place to allow student movement among schools. Per school district policy, the deadline for application for student transfer is in the spring, prior to the new school year, yet the board reserves the right to make a final decision after space and facility availability are known in the month of September. Upon receipt from the district, student-athletes who are forced to move schools as per this district policy will be eligible at their receiving school.

933.0 STUDENT-ATHLETE HAS TRANSFERRED SCHOOLS FOR A BONA FIDE ACADEMIC REASON

"Bona fide academic reason" is defined as a minimum of three (3) courses in a 'related program of study' not available to the student-athlete at their previous school. Courses that are directly related to Sport or Human Performance, where credits are being issued for the execution of sport training activities, either in a multi-sport, or sport-specific application will not be eligible for consideration when evaluating the merits for an Eligibility Application on the grounds of bona fide academic transfer;

Where an exemption is granted by the Eligibility Officer on the basis of a transfer for an academic reason, the exemption shall cease to have effect if the student-athlete withdraws from the program, group of courses or other academic offerings underlying the exemption, unless and until the Eligibility Officer, on written application by the school, confirms the exemption.

934.0 THE STUDENT-ATHLETE HAS TRANSFERRED SCHOOLS BECAUSE OF FINANCIAL HARDSHIP

"Financial hardship" is defined as a when a student-athlete or their family is willing but unable to meet their obligations because of unexpected events or unforeseen changes that impacts their financial viability (i.e. Changes in income or expenditure. Changes in employment status, such as losing a job or having hours reduced).

935.0 THE STUDENT-ATHLETE HAS TRANSFERRED SCHOOLS BECAUSE OF BULLYING

Bullying" is defined as unwanted aggressive behaviour that involves real or perceived power imbalance. The behaviour is repeated or has the potential to be repeated over time. In order to be considered bullying, the behaviour must be aggressive and include; an Imbalance of Power where kids who bully use their power-such as physical strength, access to embarrassing information, or popularity-to control or harm others. Power imbalances can change over time and in different situations, even if they involve the same people or, Repetition where bullying behaviours happen more than once or have the potential to happen more than once.

For consideration by the Eligibility Officer, the leaving school must acknowledge in writing the student was subject to actions that meet the standards above while attending their school and believe the transfer to be in the best interest of the student's overall health and well being.

Member schools may only submit one eligibility submission per student-athlete, per academic year. An eligibility submission is done through the use of a Change of Residence Form or an Eligibility Application.

942.0 NOTIFICATION OF TRANSFER FORM

This form confirms a transfer of a student-athlete and eligibility in sports not participated in in the last 12 months. A Notification of Transfer form must be signed and submitted by the administrator and athletic director of the receiving school and the student-athletes parent(s) or legal guardian(s) for the transfer to be completed.

941.0 CHANGE OF RESIDENCE FORM

A Change of Residence Form is required when a student-athlete changes their residence and must be authorized by the school administrator and signed by student-athlete's and parent(s) or legal guardian(s). Change of Residence Forms must be submitted within 12 months of the date of move. Change of Residence Forms shall be submitted for;

- A Parent-to-Parent move,
- Move to a Legal Guardian or;
- Change of Principal Residency

941.1 Should a member school submit a Change of Residence which is denied by the Eligibility Officer(s); the member school may appeal the decision directly to the Eligibility Appeals Committee as per 644.0.

941.2 After a ruling where eligibility is approved and where subsequently the Executive Director receives new information pertaining to the student-athlete in question that they deem credible and has the potential to affect the original decision, the Executive Director may request the Eligibility Officer to review the ruling in light of the new information, and if they deem necessary, issue a new ruling.

943.0 ELIGIBILITY APPLICATION

943.1 Where a student-athlete is ineligible for BCSS competition pursuant to BCSS policy, the member school may apply for exemption for the student-athlete in accordance with this section. An Eligibility Application under 642.0 must be submitted to the Eligibility Officer (EO) through the BCSS office and shall contain.

- A completed and signed BCSS Eligibility Application;
- Disclosure of the eligibility application to the leaving school including reference to the eligibility rule upon which the application is based;
- A copy of the student-athlete's personal record card (public schools), or report cards and transcripts (independent schools);
- A list of the student-athlete's current courses;
- A copy of a primary source document showing the student-athlete's date of birth (e.g. birth certificate, passport, permanent resident card, provincial identification card);
- A letter from the student-athlete's parent or legal guardian supporting the application;
- Copies of relevant medical documentation where the application is based on medical grounds; and
- Any other information or clarifying material relevant to the student-athletes eligibility

943.2 The applicant school will be invoiced a \$50 non-refundable application fee.

943.3 The Eligibility Officer may request further information from applicant school.

943.4 The Eligibility Officer may use information as available to them in their capacity as the Eligibility Officer of BC School Sports, or otherwise publicly available to assist in the rendering of a decision.

943.5 The Eligibility Officer may request further information from other parties deemed relevant by the EO. Any information received for consideration under 642.0 will be disclosed to the applying member school, with an invitation for response from the applying school, prior to rendering a decision.

943.6 There is no right to teleconference or oral hearing before the Eligibility Officer.

943.7 The Eligibility Officer shall thoroughly evaluate the submissions for completeness and veracity. They shall then consider the information in the application against the Bylaws and Policies. The primary purpose of the eligibility process is to promote fair and equitable competition for all student-athletes participating in BCSS competition.

943.7.1 If in the opinion of the Eligibility Officer, a student-athlete transfer is motivated by sport, and has previously established their home school, the Eligibility Officer may deny eligibility on those grounds.

943.7.2 The Eligibility Officer shall issue a written ruling to the applicant school (to the attention of the administrator and the athletic director) either approving or denying the application and containing a brief summary of the reasons for the decision.

- 943.7.3 After a ruling where eligibility is approved and where subsequently the Executive Director receives new information pertaining to the student-athlete in question that they deem credible and has the potential to affect the original decision, the Executive Director may request the Eligibility Officer to review the ruling in light of the new information, and if they deem necessary, issue a new ruling.
- 943.8 Subject to 942.0, if the Eligibility Officer allows the application, the student athlete becomes eligible for competition on the date the decision is issued, provided, however, that the student-athlete's eligibility remains otherwise subject to the Bylaws and Policies.
- 943.9 It is the responsibility of the applicant school to notify the student-athlete and the student-athlete's parent(s) or legal guardian(s) of the decision of the Eligibility Officer and of any requests or other communications from the Eligibility Officer.

944.0 ELIGIBILITY APPEALS

Should a member school apply for a waiver of the one-year ineligibility period under the Transfer Policy (912.0) through the use of a Change of Residence or Eligibility Application and the request is denied by the Eligibility Officer(s); the member school may appeal the decision to the Eligibility Appeals Committee (EAC). An appeal under 944.0 shall be in writing and submitted to the BCSS office by 2:00pm (PT) for forwarding to the committee three (3) full days before the next scheduled meeting of the EAC.

- 944.1 The Appeal may contain:
- A completed and signed BCSS Eligibility Appeal Form;
 - Additional information in response to the Eligibility Officer(s) ruling
- 944.2 The member school appealing will be invoiced a \$250 appeal fee; where \$200 is refunded upon successful appeal decision.
- 944.3 The EAC may request further information from the applicant school.
- 944.4 The EAC may use information as available to them in their capacity as a committee of BC School Sports, or otherwise publicly available to assist in the rendering of a decision.
- 944.5 The EAC may request further information from other parties deemed relevant by the EAC. Any information received for consideration under 944.4 will be disclosed to the applying member school, with an invitation for response from the applying school, prior to rendering a decision.
- 944.6 There is no right to a teleconference or oral hearing before the EAC.
- 944.7 The EAC shall thoroughly evaluate the Eligibility Appeal submissions for completeness and veracity. The committee shall then consider the information in the application and shall approve or dismiss the appeal, having regard of the Purposes, Bylaws and Policies of BCSS.
- 944.8 The EAC may substitute its views for that of the Eligibility Officer and is granted authority to make exceptions to the Bylaws and Policies of BCSS.
- 944.9 The EAC shall issue a written ruling to the applicant school (to the attention of the administrator and the athletic director) either approving or dismissing the appeal, and containing a brief summary of the reasons for the decisions.
- 944.9.1 After a ruling where eligibility is approved and where subsequently the Executive Director receives new information pertaining to the student-athlete in question that they deem credible and has the potential to affect the original decision, the Executive Director may request the EAC to review the ruling in light of the new information, and if they deem necessary, issue a new ruling.
- 944.10 Subject to 944.6, if the EAC allows the appeal, the student-athlete becomes eligible for competition on the date the decision is issued, provided, however, that the student-athlete's eligibility remains otherwise subject to the BCSS Bylaws Policies.
- 944.11 It is the responsibility of the applicant school to notify the student-athlete and the student-athlete's parent(s) or legal guardian(s) of the decision of the EAC and of any requests or other communications from the EAC.
- 944.12 Where an exemption is granted by the EAC on the basis of a transfer for an academic reason, the exemption shall cease to have effect if the student-athlete withdraws from the program, group of courses or other academic offering underlying the exemption, unless and until the EAC, on written application by the school, confirms the exemption.
- 944.13 The decisions of the EAC under 643.0 and the Eligibility Officer under 642.0 are final and binding and shall not be questioned or reviewed in any court or tribunal, and no order shall be made or process entered or proceeding taken in any court or tribunal whether by way of injunction, declaration, prohibition or otherwise to question, review, prohibit or restrain the proceedings.

944.14 The Eligibility Appeals Committee will meet for the school year in 2021-2022 as noted below:

Deadline for Submission (Tuesdays- 2:00pm)	Meetings (Saturdays)
September 14, 2021	September 18, 2021
September 28, 2021	October 2, 2021
October 12, 2021	October 16, 2021
November 2, 2021	November 6, 2021
December 7, 2021	December 11, 2021
January 18, 2022	January 22, 2022
February 8, 2022	February 12, 2022
March 1, 2022	March 5, 2022
April 5, 2022	April 9, 2022
May 3, 2022	May 7, 2022

1000: Sport Regulations

1010.0 AQUATICS

1011.0

Year	Max Number of Playing Days	First Day of Play	Last Day of Play	Minimum Numbers	Season of Play
2021/22	15	Week 6; Mon	Week 16; Sat	1	Fall
2022/23	15	Week ; Mon	Week ; Sat	1	Fall
2023/24	15	Week ; Mon	Week; Sat	1	Fall

1012.0**RULES OF PLAY**

The rules governing BCSS Aquatics shall follow those of Swimming Canada with the following modifications;

- 1012.1 One Start Rule
There will be one start signal for each race. Should an athlete start the race before the signal they will be disqualified. There will be no restart, the race will continue on the single start for those who started legally.
- 1012.2 Relay Rules
- All relay events must have four (4) different athletes from the same school
 - Mixed relays must consist of two (2) male athletes and two (2) female athletes, mixed relays from two single-gendered schools are prohibited
 - Any athlete who competes at zones is permitted to swim on a relay team at provincials
 - The order on the relay card is the order that the swimmers MUST use in the race. Failure to swim in the same order will result in a disqualification
 - No more than 2 teams for each school will be allowed to compete at provincials in each relay event
- 1012.3 Competitors must only wear one swimsuit made from textile materials and have no zippers. Male athletes, the suit shall not extend above the navel or below the knee. Female athletes, the suit shall not cover the neck, nor extend past the shoulder, nor extend below the knee.
- 1012.4 Swimmers will be classified as "A", "B" or "Para" swimmers according to the following criteria:
- 1012.4.1 "A" Swimmers are defined as:
- Any swimmer with an SNC (Swimming Natation Canada) number who has competed in a Winter Swim Meet as of September 1 of the previous year
 - Swim academy athletes
- 1012.4.2 "B" Swimmers are defined as:
- As of January 1st of the championship year, the swimmer trains and competes from May 1st to September 1st with no restrictions.
 - From September 2nd to April 30th, the swimmer may train with their high school team and may participate in other speed swimming training such as winter maintenance, tri club, and private coaching.
 - They may not compete in a Winter Swim Meet with an SNC number
- 1012.4.3 "Para" Swimmers are defined as:
- Swimmers with a disability, they are not required to be classified or have an SNC number
- 1012.4.4 Exceptions
- "B" Swimmers may compete in any A Category event as the BCSS Aquatics Championships is not SNC sanctioned. No SNC number is required.
 - "A" swimmers cannot compete in any B Category event.
 - B swimmers may compete in A or B category relays, but may not swim the same relay in both A and B categories.

1013.0

OFFICIALS

Officials at the BCSS Aquatics Provincial Championship will be certified Swim BC Officials.

1014.0

PROVINCIAL CHAMPIONSHIPS

1014.1

EVENTS

1014.1.1 The following events will be contested in boys and girls, "A", "B" and "Para" competition categories:

- 50 Freestyle
- 50 Backstroke
- 50 Breaststroke
- 50 Butterfly
- 100 Freestyle
- 100 IM

1014.1.2 The following events will be contested in boys and girls, "A" and "B" competition categories:

- 100 Backstroke
- 100 Breaststroke
- 100 Butterfly
- 200 Medley Relay
- 200 Freestyle Relay
- 400 Freestyle Relay

1014.1.3 The following events will be contested in the "A" and "B" competition categories:

- 200 Mixed Medley Relay
- 200 Mixed Freestyle Relay

1014.1.4 All swimmers are limited to a total of 4 events, including relays and alternate entries.

1014.1.5 Any swimmer who competes at a zone meet is eligible to swim on a relay at Provincial Championships.

1014.1.6 A swimmer may not scratch from an individual event at provincial in order to move into a relay event.

1014.1.7 Mixed relay teams must include 2 boys and 2 girls from the same school, single gender schools are not permitted to join for the purpose of creating a mixed relay team.

1014.1.8 Relay team swimmers may be changed between the zone meet and Provincial Championships but not between heats and finals at Provincials, unless a designated alternate is being used.

1014.2

BERTHING

Zone representation berthing (number of entries) is based on the numbers-based-allocation formula determined by BC School Sports. A maximum of two (2) relay teams per school per event are permitted to advance to provincials.

$$\frac{\text{Total Number Schools with Registered Teams}}{\text{Total Number of Eligible Berths}} = \text{Berthing ratio}$$

* If a zone does not have any teams participating that berth will go back into the total number of eligible berths.

$$\frac{\text{Total Number Schools with Registered Teams}}{\text{Teams/Zone Berthing Ratio}} = \text{Number of Berths/zone}$$

1014.3

CHAMPIONSHIP STRUCTURE

The Championship meet will consist of preliminary and final heats in each event. Individual and relay events will include a championship final (1-8) and a consolation final (9-16).Heats will be determined by

the championship host committee with collaboration with the BCSS office based on entry times from zones.

1014.3.1 Scratches

A swimmer may not scratch an individual event at provincials in order to move into a relay event, if a swimmer scratches in an individual event they will be disqualified for any relay events. If a coach decides to scratch an athlete after the designated time they will be fined \$50 for an empty lane fee.

1014.3.2 Alternates

Alternates must be submitted no later than 30 minutes before the start of the meet, but it is preferable for the sake of scheduling that all alternates are submitted at the time of meet entries prior to provincials.

1014.4 SCORING

Individual Events

1 st	2 nd	3 rd	4 th	5 th	6 th	7 th	8 th	9 th	10 th	11 th	12 th	13 th	14 th	15 th	16 th
20	18	16	15	14	13	12	11	10	8	6	5	4	3	2	1

Relay Events

1 st	2 nd	3 rd	4 th	5 th	6 th	7 th	8 th	9 th	10 th	11 th	12 th	13 th	14 th	15 th	16 th
40	36	32	30	28	26	24	22	20	16	12	10	8	6	4	2

PARA

Scoring is a reverse format and based on the number of swimmers in each event.

Example: 8 Swimmers: 20 -18 -16 -15 -14 -13 -12 -11

4 Swimmers: 14 - 13 - 12 - 11

1 Swimmer: 11

1014.5 AWARDS (PER TIER/PER GENDER)

- BCSS Blue Championship Banner (6)

1017.0 CHAMPIONSHIP HOSTING REQUIREMENTS

BCSS recognizes that most member schools do not have the facilities to host an aquatics championship, and therefore need to book 3rd party facilities to host the championships. The facility chosen as the host location for the championship must abide by the up-to-date Swimming Canada minimum standard facility guidelines.

If your school plans on submitting a bid to host a BCSS Aquatics Championship and wants clarification on if your chosen facility has all of the requirements, please reach out to the BCSS office for further clarification.

1021.0

Year	Contest Dates	First Day of Play	Last Day of Play	Minimum Numbers	Season of Play
2021/22	26	Week 31; Mon	Week 44; Sat	5	Spring
2022/23	26	Week	Week	5	Spring
2023/24	26	Week	Week	5	Spring

1022.0

RULES OF PLAY

The rules governing BCSS Badminton shall be those of the Badminton World Federation with the following modifications;

- 1022.1 Pre-Match & Game Procedures/Understanding
- 1022.1.1 Before commencing a match, players determine the starting player or team via a “Bird Drop” of which the winner has the choice of either: serving first, receiving first, or side of court
- 1022.1.2 All games will be rally point to 21 points, if the score gets to 20 - 20, then the match will continue until one player or team wins by 2 points. At 29 all the first team to 30 wins
- 1022.1.3 A tie is comprised of 11 matches with each match consisting of the best 2 out of 3 games. The winning team is the one that wins 6 or more matches in the tie
- 1022.1.4 Once a match is announced for play, players will have a total of five (5) minutes to get on court and complete a warm-up
- 1022.1.5 Coaches must submit their BCSS Badminton Score Sheet Line up to the score desk no fewer than ten (10) minutes prior to the start of each tie
- 1022.1.6 Coaches must designate one individual on the Badminton Score Sheet Line up as the coach
- 1022.1.7 The following matches will be played during a tie:
- Girls Singles
 - Girls Doubles
 - Boys Singles
 - Boys Doubles
 - Mixed Doubles
- 1022.2 Players Cannot leave the court between games at any time, are required to clearly announce the score between each service and while on the court to communicate any issues with the designated coach for the tie.
- 1022.3 Coaches
- 1022.3.1 The coach designated on the Badminton Score Sheet Line up is the only coach that can address players during a game in-between points. The coach designated on the Badminton Score Sheet Line up must only coach in-between rallies and must not interfere with flow of the game
- 1022.3.3 Assistant coaches can only coach players during the two (2) minute break between games 1 and 2 and games 2 and 3. Assistant coaches can provide feedback to the coach during game play as long as the coach is the only individual directly addressing the players
- 1022.4 Intervals at 11:
- Players have the discretion to take a 30 second water break in any game when the first player reaches 11 points.
 - Players will switch sides when the first player reaches 11 in the third game of a match, however no on court coaching will be allowed.
- 1022.5 If a player is consistently serving illegally, and the breach is blatant, the coach noting the infraction is to speak to the player’s coach, and request to warn the player. If in the opinion of a coach, the service rules continue to be breached, then a service ruling can be requested and organized by other neutral coaches/managers within that pool or playoff group
- 1022.6 Team Gender Requirements: Schools must have a minimum of five (5) girls and five (5) boys in order to compete prior to the start of Championships, coaches must submit the following:
- Declare eligible players on the “Team Line Up” form
 - List male and female players in order of strength

- Attach BCSS Roster to “Team Line Up” form

- 1022.7 Alternates
- 1022.7.1 If a player is injured in a match and cannot play within reasonable time (approximately five (5) minutes) they will default the match
- 1022.7.2 A substitute may play in the remaining match of the injured player as long as it is changed with the scorekeeper and the opposing teams coach is notified. This match is considered as an official match in the Tie
- 1022.7.3 The team must default at least one match in the Tie that a player cannot continue, and the injured player cannot play in a different match in that same tie.
- 1022.7.4 A player who is injured in a Tie does not preclude them from participating in any remaining Ties

1023.0

EQUIPMENT

- 1023.1 Shoes appropriate for court play that are constructed of non-marking soles
- 1023.2 Appropriate badminton attire that consists of a shirt and shorts. Team uniforms using school colours, or the official competition t-shirt is recommended.
- 1023.3 Generally speaking, as a sign of sportsmanship, it is asked not to wear sweatpants during match play.

1024.0

OFFICIALS

All officiating at BCSS badminton events will be self-officiated by players

- 1024.1 Players are to only call the lines on their own side of the court
- 1024.2 Calls are to be immediate and assertive with no help from the spectators
- 1024.3 If a player has a doubt, the request for an umpire or line judge is through the designated coach in-between games
- 1024.4 Umpires and line judges are to be organized by other neutral coaches/managers within that pool or playoff group

1025.0

PROVINCIAL CHAMPIONSHIPS

1025.1 EVENTS

- 1025.1.1 All players must play in their designated position for the completion of the tie
- 1025.1.2 If a team does not have a minimum of ten (10) players listed at the time of the “Line Up” submission, the school will default the matches the missing players would have played
- 1025.1.3 A different set of players may be used on next and subsequent ties
- 1025.1.4 After six (6) matches have been won/lost, the designated coach can change their line up with the knowledge of the other coach and the draw desk with no penalty

1025.2 BERTHING

1025.2.1 Each of the 9 BCSS Zones will receive 1 automatic berth, the remaining at-large berths will be allocated based on a 16:1 participation ratio determined by the number of registered teams in the zone. For every 16 teams (with a full 10 athlete team composition) a zone has registered they will receive an additional berth. If there are remaining berths, they will be awarded as at-large berths based on historical zone strength, using the zones historical provincial championship results of their top 2 teams.

1025.2.2 If a zone is unable to fill their berths, the berth will be awarded as an at-large berth based on historical zone strength. This formula will be calculated using the average Provincial Championship result for each zone over the previous five Provincial Championships using their top 1 or top 2 teams.

1025.3 TOURNAMENT STRUCTURE

- 1025.3.1 Sixteen (16) team tournament, divided into four (4) pools as illustrated below
- 1025.3.2 Wherever possible, teams from the same zone will not play each other in power pool

competition and if possible they will be placed in such that they may not face each other until the quarter or semi finals

1025.3.2.1 POWER POOL STRUCTURE

Pool A	Pool B	Pool C	Pool D
1	2	3	4
6	5	8	7
11	12	9	10
16	15	14	13

1025.3.2.2 CHAMPIONSHIP DRAW

BCSS Badminton Championship Draw

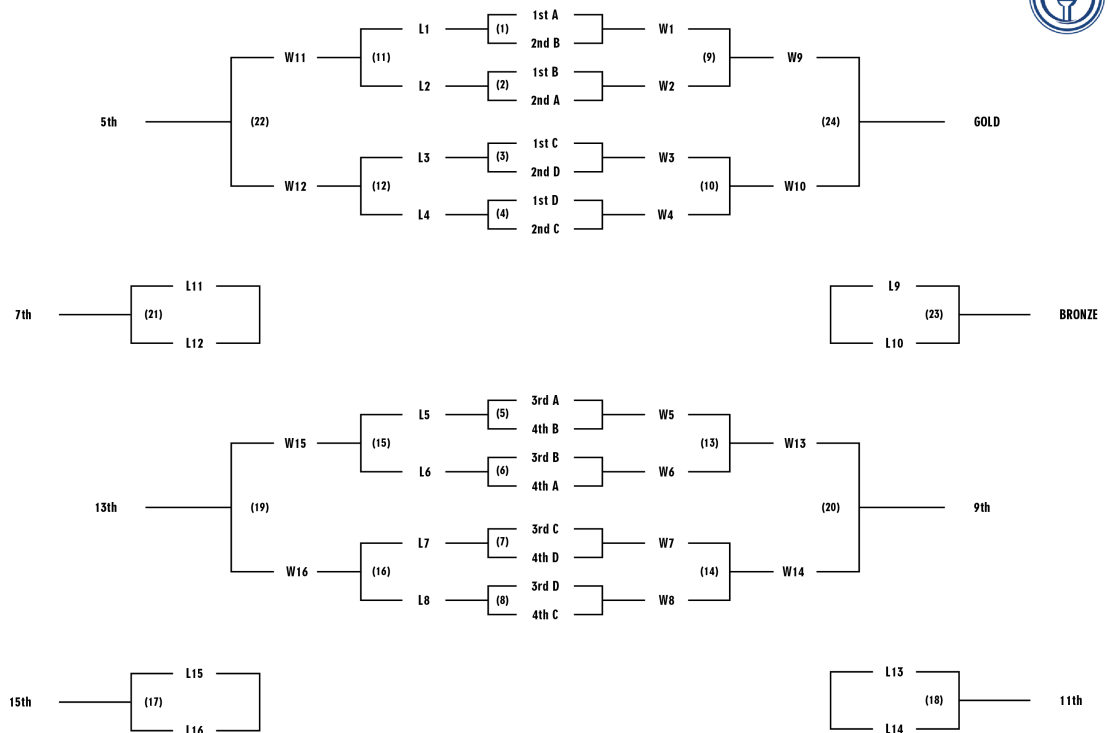

1025.3.3 After round robin play, teams will be ranked one to four (1-4) in their pools. All teams will be placed into the championship draw based on their placement during the power pools.

1025.3.4 The matches will be played in the following order, the first team listed is designated as the home team;

- Girls Doubles A vs B
- Girls Doubles B vs A
- Boys Doubles A vs B
- Boys Doubles B vs A
- Girls Singles
- Boys Singles
- Girls Doubles A vs A
- Girls Doubles B vs B
- Boys Doubles A vs A
- Boys Doubles B vs B
- Mixed Doubles

1025.4

TIE BREAK PROCEDURE

If at the conclusion of the round-robin, two or more teams are tied,

- If two (2) teams are tied, the team who won the Tie between the two schools will be the winner (Head to Head)
- If three (3) teams are tied, the results from the three Ties that occurred will be broken down as follows:

follows:

- School that won the most matches is First (1st)
- If they are still tied, then the school that loses the least number of games is First (1st)
- If still tied, then the team with the least number of points against is First (1st)
- If still tied, then the authority is given to the Championship Host Committee Chair to break the tie in a manner that they feel is the fairest

1025.5

AWARDS

- BCSS Blue Provincial Championship Banner
- 16 MVP plaques and Sportsmanship Package (1 per team)
- The Rich West Sportsmanship Trophy
- BCSS Medals for the 1st, 2nd, and 3rd place teams

1026.0 CHAMPIONSHIP HOSTING REQUIREMENTS

The facility chosen as the host location for the championship must have adequate space to host and organize at least 24 badminton courts. In the event that the pre-determined central locations are not available, schools are encouraged to contact the BCSS office before submitting a bid to host a BCSS Badminton Provincial Championship.

1030.0 BASKETBALL

1031.0

Year	Maximum Contest Dates	First Day of Competition	Last Day of Play	Minimum Numbers	Season of Play
2021/22	32	Monday: Week 18	G-Week 31 B- Week 32	7	Winter
2022/23	32	Monday: Week	G-Week B- Week	7	Winter
2023/24	32	Monday: Week	G-Week B- Week	7	Winter

1032.0 RULES OF PLAY

The rules for governing BCSS Basketball shall be Federal International Basketball Association (FIBA) with the following modifications:

1032.2 In the last two (2) minutes of the game - a defensive player shall not move over the boundary line. After a warning, with the preventative warning signal, any further action shall result in a Technical Foul.

1032.3 All throw-ins as part of any Unsportsmanlike foul or disqualifying foul, shall be administered from the frontcourt throw-in spot. In all cases, the team awarded the throw-in shall have
BOYS: fifteen (15) seconds on the shot clock
GIRLS fourteen (14) seconds on the shot clock.

1032.4 Shot Clock

1032.1 BOYS ONLY: Thirty (30) shot clock, full reset after the ball strokes the ring

1032.4.1 Following a foul or violation against the team in control of the ball, the opponent shall be awarded a throw in:

- Occurring in the backcourt - reset to
BOYS: thirty (30) seconds
GIRLS: twenty-four (24) seconds
- Occurring in the frontcourt - reset to
BOYS: thirty (15) seconds
GIRLS: fourteen (14) seconds

1032.4.2 During the last two (2) minutes of the game - when a time-out is awarded in offensive team's backcourt, the coach has the option of retaining possession in their team's backcourt or moving the ball to the throw-in spot in the front court.

1032.4.2.1 Following the time-out, the Head Coach must immediately inform the closest official which option is to be taken. Failure to do so - the throw-in shall remain in the team's backcourt.

- Backcourt throw-in after an opponent's foul, violation or legal score—
BOYS: thirty (30) seconds
GIRLS: Twenty-four (24) seconds No reset if out-of-bounds, double foul or possession arrow
- Advanced to the frontcourt – if more than 15 seconds (Boys) or 14 seconds (girls) reset to
BOYS: fifteen (15) seconds;
GIRLS: fourteen (14) seconds
- Advanced to the frontcourt - no reset if less than BOYS: fifteen (15) or GIRLS: fourteen (14) seconds is on the shot clock.

1032.5 Technical Foul:

One (1) free throw to be administered immediately (but following a time-out, if applicable). Following the Technical foul free throw(s), play to resume: ball returns to the team which was in control of the ball or to the team entitled to the ball.

- 1032.6 Ball lodges between the ring and backboard, the shot clock is reset to
BOYS: thirty (30) seconds
GIRLS: twenty-four (24) seconds
- 1032.7 FIBA pre-game warm-up procedure shall NOT be used.
- 1032.8 Home team (or as designated by the tournament) shall have choice of team benches and will shoot at the basket furthest from that bench in the first half
- 1032.9 Each team shall be permitted their three (3) allotted time-outs at any time during the second half. A maximum of two (2) time-outs in the final two (2) minutes of the fourth (4th) period no longer applies. Unused time-outs shall not be carried over to any extra period.
- 1032.10 Under no circumstance shall any video system be used for an official, coach, game director or administration to clarify any on-court rules interpretation.
- 1032.11 The no charge semi-circle shall apply at the discretion of the officials
- 1032.12 Teams must be on the field of play ready to play (with the required number of players) within ten (10) minutes of game time. Failure to do so will result in forfeiture. Referees will inform the Tournament Director after ten (10) minutes of game time which team defaulted.

1033.0

EQUIPMENT

- 1033.1 Ball
- The Championship Ball is the Baden Elite Basketball (29.5 for Boys, 28.5 for Girls)
- 1033.2 Uniforms
- T-shirts shall be permitted BUT the t-shirts must be the same colour as the team's jersey. Sleeves, leggings, or spandex that appear below shorts may be any colour.
 - Religious or medical bracelets/necklaces are permitted but must be covered by tape or a sweatband.
 - Teams shall use FIBA International Rules for uniform numbering

1034.0

OFFICIALS

All BCSS Basketball Provincials will be officiated by certified officials of the BC Basketball Officials Commission

PLAYING UP

Teams have the option of playing up to a classification that is higher than their normal designation. Generally, this should only be used for teams that have demonstrated a prolonged level of success in the classification they are in and would generally be considered to be a team capable of a 'Top-8' provincial finish at the higher classification to justify the playing up. Playing up is not intended to be used for teams to find an "easier" path to provincials by opting up to a classification that may have less competition.

Teams will follow the following process to apply to move up a classification. Any team that moves up in a classification must do so at the start of the 2-year classification cycle and will remain there for both years of the classification cycle.

The Playing Up procedure will be evaluated and inserted prior to the next opportunity to play up in 2022-2023 season.

1035.0

IN SEASON RANKINGS

The Executive Director at the recommendation of the Boys Basketball SAC Chair will appoint one person per classification to conduct the in-season rankings. This person will evaluate game results, speak with coaches, and provide a weekly ranking of no more than 10 teams and up to a maximum of 5 honourable mentions. They will be provided to BCSS and the SAC chair with a basic rationale in accordance with the agreed upon schedule.

1036.0

PROVINCIAL CHAMPIONSHIPS

1035.1 EVENTS

There will be eight (8) BCSS Basketball Provincial Championships. Each championship, as listed below will consist of a 16-team tournament.

- 1036.1.1 Girls: A; Girls AA; Girls AAA; Girls AAAA
- 1035.1.2 Boys A; Boys AA; Boys AAA; Boys AAAA

1035.2 BERTHING

1035.2.1 Boys Basketball Berthing

- Qualification for the tournament will happen at the zone level.
- Each team that wins their respective Zone Championship will automatically earn a berth to provincials. (9 teams).
- There is no host berth in the boys basketball championships
- The remaining seven (7) at-large berths will be allocated based on the number of participating teams as listed below;

Total Number Schools with Registered Teams

$$\frac{\text{Total Number Schools with Registered Teams}}{\text{Total Number of at-large berths}} = \text{Berthing ratio}$$

* If a zone does not have any teams participating that berth will go back into the total number of at-large berths

$$\frac{\text{Total Number Schools with Registered Teams}}{\text{Teams/Zone Berthing Ratio}} = \text{Number of Berths/zone}$$

1035.2.2 Girls Basketball Berthing

- Qualification for the tournament will happen at the zone level.
- Teams who win their Zone Championship will automatically have a spot in Provincials (9 teams), another berth will be awarded to the host school (1). The remaining six (6) at-large berths will be allocated as followed
 - Two (2) berths based on participating numbers
 - Four (4) berths based on historical strengths of teams
- If a zone does not have any teams participating that berth will go back into the total number of eligible at-large berths.
- The seeding committee in cooperation with BC School Sports will submit the total berths per zone shortly after the Fall Team Registration Deadline

1035.3 STRUCTURE

1035.3.1 Boys and Girls Basketball Structure

All Provincial Tournaments shall consist of sixteen (16) teams.

- The Provincial Tournament shall be played over four (4) days

BCSS Boys & Girls Basketball Championship Draw

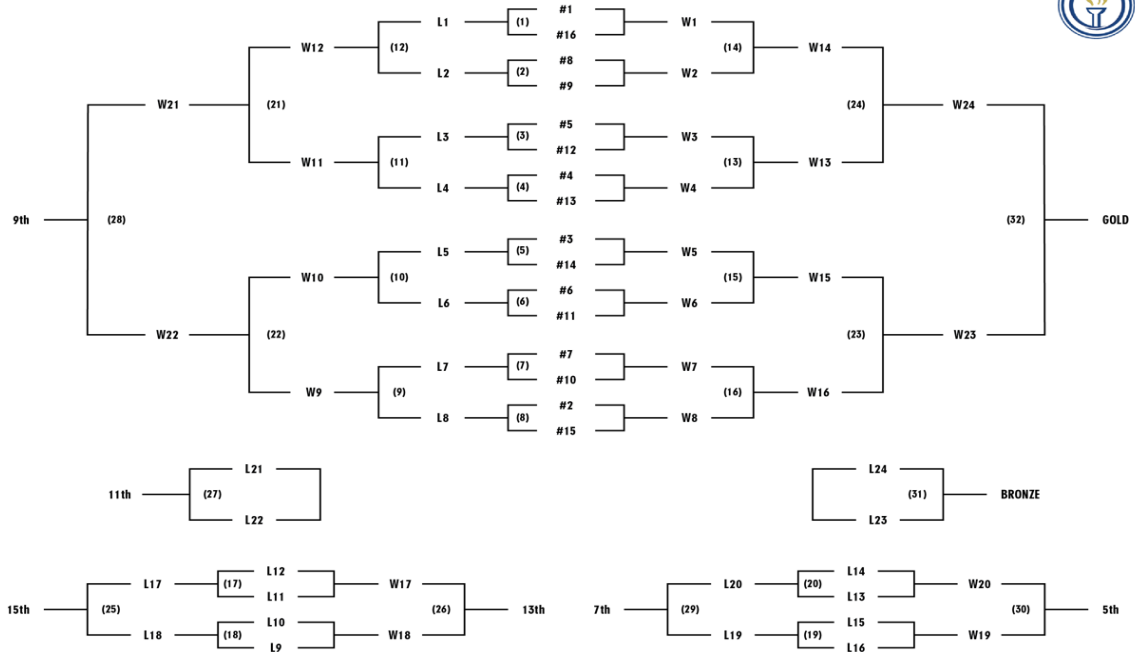

1035.4 CHAMPIONSHIP SEEDING

A seeding committee will be appointed by the Executive Director at the recommendation of the SAC Chair and the Tournament Director. The committee will meet on the weekend prior to the championship beginning to seed the championship draw based on the established philosophies and guidelines for championship seeding.

1037.0 AWARDS

• **BOYS BASKETBALL**

- A BCSS Championship Banners will be awarded to the winning team of each championship (4 events)
- Gold, Silver and Bronze medals will be awarded to the top 3 teams of each tournament. Each team will be provided 15 medals. (Additional medals can be purchased through BCSS)
- 1st and 2nd All Star Teams of 5 student-athletes on each team.
- Most Valuable Player
- Best Defensive Player
- Sportsmanship Award (1 team)
- Spirit award (AAAA only)
- “Player of the Game” awarded to one player from each team at the championship
- Finishing Plaques for all 16-teams in each tournament.
- 1-8 placement trophies

• **GIRLS BASKETBALL**

- BCSS Championship Banners will be presented to the top school based on their overall team performance in each championship (8 banners total)
- Medal Winners- 15 medals will be awarded to the top 3 teams

1040.0 CROSS COUNTRY

1041.0

Year	Contest Dates	First Day of Play	Last Day of Play	Minimum Numbers	Maximum Roster (@ provincials)	Season of Play
2021/22	15	Mon; Week 6	Sat; Week 14	1	7	Fall
2022/23	15	Week		1	7	Fall
2023/24	15	Week		1	7	Fall

1042.0**RULES OF PLAY**

The rules governing BCSS Cross Country shall be those of BC Athletics with the following rule modifications;

- 1042.1 Athletes are required to compete at one sanctioned school league cross country meet before participating in zone championships
- 1042.2 Athletes must qualify to Provincial Championships through their Zone Championship Meet
- 1042.2.1 An athlete may be allowed to compete at Provincial Championships without having qualified in their Zone Championships given exceptional circumstances. Tournament Director & three (3) elected representatives will rule on whether an athlete qualifies based on exceptional circumstances.
- 1042.2.2 An application for exemption must be emailed by the appropriate zone representative to BC School Sports on the Friday, eight days before the Provincial Championship event
- 1042.2.3 The Championship committee along with the BCSS Office will use the following criteria to determine qualification;
- Runner must have top twenty-five (25) potential at Provincials - they should be a top five (5) runner in league races during the season, smaller zones - top three (3).
 - Exceptional circumstances may include;
 - A serious traffic issue (car accident or delayed ferry)
 - A funeral
 - Medical Issues, including serious illness
- Note: Conflict with another sport, an exam, a school field trip, or a family event does not qualify as an exceptional circumstance
- 1042.2.4 Any decision made by the Championship Committees final, if qualification is granted the athlete must represent their school at the BCSS Provincial Championships.
- 1042.3 The start line should be straight/arched and at least seventy meters (70m) wide to accommodate fifty-five chutes (55) of 1.25 meter width and long enough to channel runners safely into the course.
- 1042.4 The start and finish chute should be around the same area and should extend for at least two hundred and fifty (250) meters without narrowing, turning, or ascending/descending a hill.
- 1042.5 The finish line should be five (5) meters wide with the chute narrowing approximately to one (1) meter at about fifteen (15) meters past the finish line and extending approximately forty (40) meters
- 1042.6 The course should be able to handle approximately three hundred (300) runners per race and should be wide enough for at least three (3) runners side by side, or approximately five (5) meters to allow for passing.
- 1042.7 No league meets can take place within 5 days of the zone championship
- 1042.8 All runners must compete in the same age category at Zone and Provincial Championships

1043.0 EQUIPMENT

- 1043.1 BCSS Cross Country Championship bibs must be worn and visible at all times during the competition
- 1043.2 Athletes must have matching school uniforms, no club representation will be permitted.

1045.0 OFFICIALS

All BCSS Cross Country Championships will use Chip Timing as their official. Chips are embedded in the athletes bibs and are to be picked up by the athlete when arriving at Provincials. Coaches are not permitted to have any chips on them at any time throughout the competition. For purposes of calculating results, athletes are required to wear the timing chip at all times once they are lined up for their race.

1046.0 PROVINCIAL CHAMPIONSHIPS

1046.1 EVENTS

1046.1.1 The BCSS Cross Country Provincial Championships will be comprised of 4 races; a junior and senior race in both boys and girls categories. Each race must be within the distance range as stated below;

- Junior Boys: Approx. 4km
- Junior Girls: Approx. 4km
- Senior Boys: Approx. 5km
- Senior Girls: Approx. 5km

1046.2 ASSIGNMENT OF STARTING LINE CHUTES

Runners from each zone and associated schools are to be positioned by number from left to right facing the running area. Numbers will be assigned to both individuals and teams from each zone on a yearly rotating basis.

1046.3 BERTHING

1046.3.1 Team Qualification

- 30 team berth spots will be awarded between each zone per event
- Maximum of seven (7) athletes for both the boys & girls races.
 - The first four (4) runners will score for their team for the purpose of qualification
 - Using displacement, the fifth (5th), and sixth (6th) place finishers of a team do not score for their team, but hold their place in the race.
 - The tournament committee is cooperation with BC School Sports will submit the total berths per zone shortly after the Fall Team Registration Deadline using the following berthing ratio;

$$\frac{\text{Number of teams at the zone champs}}{\text{Total number of teams at all zone champs}} = \text{Berthing ratio}$$

$$\frac{\text{Number of total berths available}}{\text{berths}} = \text{Total number of team berths}$$

Berthing ratio (per zone)

1046.3.2 Individual Qualification

- 90 individual berths will be awarded between each zone per event. All zones will get 3 automatic individual berths to provincials per event, to be given to the top 3 finishers in each race that did NOT qualify as a team.
- The remaining 63 individual berths will be allocated based on the following berthing ratio:

$$\frac{\text{Number of individuals at the zone champs}}{\text{Total number of individuals at all zone champs}} = \text{Berthing ratio}$$

$$\frac{\text{Number of total berths available}}{\text{Berthing ratio (per zone)}} = \text{Total number of individual berths}$$

- Zones are responsible for filling these spots prior to the provincial registration deadline

1046.4 TIE BREAK PROCEDURE

A tie between 2 teams is broken by the finishing position of the 4th runner on the team.

1047.0 AWARDS

- BCSS Championship Banners and championship trophy will be presented to the top school based on their overall team performance in each race for a total of 4 banners to be presented (Jr Boys, Jr Girls, Sr Boys, Sr Girls).
- Top 25 team ribbons (Rosettes to 4th-10th)
- Ribbons for top 25 racers in each race category
- Photo Plaques to top 3 teams in each race
- BCSS Medals for the 1st, 2nd, and 3rd place team finishers
- BCSS Medals for the 1st, 2nd, and 3rd place runners in each race

1050.0 CURLING

Year	Number of Playing Days	First Day of Play	Last Day of Play	Minimum Numbers	Maximum Roster for Championship	Season of Play
2021/22	15	Week 18; Mon	Week 31; Sat	4	5	Winter
2022/23	15	Week	Week	4	5	Winter
2023/24	15	Week	Week	4	5	Winter

1052.0**RULES**

The rules governing BCSS Curling shall follow those of Curling Canada with the following modifications;

1052.1 Each match will be 8 ends

1054.0**OFFICIALS**

Officials at BCSS Championships will be Curl BC officials, no lower than a certified level 2.

1055.0**PROVINCIAL CHAMPIONSHIP**

1055.1

EVENTS

BCSS will conduct a provincial championship, for boys' teams and girls' teams, respectively

1055.2

BERTHING

The BCSS Curling Provincial Championship will have 10 berths in each the boys and girl's category. 9 berths will be awarded to the zone champions in each of the 9 BCSS zones. The remaining 1 berth will be awarded to the host school.

If a zone is unable to or chooses not to fill their berth, the vacated berth will be awarded to the next highest finisher of the zone championship in the host school's zone.

1055.3

STRUCTURE

The championship will consist of a round robin, with each team playing every other team in the tournament once. The team with the best win-loss record at the end of the round robin play will be the provincial champion.

1055.4

TIE BREAK PROCEDURE

If time allows, where there is a tie for 1st place after the round robin, the tied teams will compete in a tie breaking game.

If at the discretion of the tournament director there is insufficient time for a tie breaking game, the winner will be determined by using the head-to-head result of the tied teams from their round robin match.

1055.5

AWARDS (Per gendered competition)

- BCSS Blue Provincial Championship Banner
- 6 Gold, 6 Silver and 6 Bronze Medals
- Regional Patches for teams placing 4th-10th
- Provincial Champion Patches for 1st- 3rd place teams
- Perpetual Trophies for 1st, 2nd, and 3rd place

1017.0 CHAMPIONSHIP HOSTING REQUIREMENTS

BCSS recognizes that most member schools do not have the facilities to host a curling championship, and therefore need to book 3rd party facilities to host the championships. The facility chosen as the host location for the championship must have at minimum 6 sheets of ice, however 9 sheets is ideal. Four sheet rinks may have to be used when no other facilities are available in a specific zone.

If your school plans on submitting a bid to host a BCSS Curling Championship and wants clarification on if your chosen facility has all of the requirements, please reach out to the BCSS office for further clarification.

1060.0 FIELD HOCKEY

1061.0	Year	Max Number of Playing Days	First Day of Play	Last Day of Play	Minimum Roster Number	Season of Play
	2021/22	26	Tues - Week 6	Sat - Week 15	11	Fall
	2022/23	26	Tues - Week	Sat - Week	11	Fall
1062.0	2023/24	26	Tues - Week	Sat - Week	11	Fall

RULES OF PLAY

The rules governing BCSS Field Hockey shall be the International Hockey Federation (FIH) with the following modifications:

- 1062.1 If, in the opinion of the tournament director and/or umpires, similarity in the colours of the uniforms may lead to confusion, one team will wear pinnies. The umpire will choose this team.
- 1062.2 Teams must be on the field of play ready to play (with the required number of players) within ten (10) minutes of game time. Failure to do so will result in forfeiture. Umpires will inform the Tournament Director after ten (10) minutes of game time which team defaulted.
- 1062.3 All BCSS Field Hockey games will be played in two (2) thirty-minute halves separated by a five (5) minute halftime.
- 1062.4 A maximum goal difference, that is the number of goals scored by one team minus that of the other team, will be 5 for any game.

1064.0 EQUIPMENT

- 1064.1 Field players may be permitted to wear soft face and head protection throughout a match for medical reasons subject to an appropriate medical certificate being submitted to the Tournament Director.
- 1064.2 Uniforms will consist of a shirt, skirt, and socks. Uniform shirts must be numbered, a player's shirt number must be consistent throughout the tournament unless otherwise approved by the Tournament Director.
- 1064.3 Shin guards and mouth guards are mandatory.
- 1064.4 Goalkeepers must wear a shirt of a different colour to both teams
- 1064.5 Each team must have an appointed captain on the pitch or on the team bench at all times during the match; that player must wear a distinctive captain's band. Should the appointed Captain be suspended or have to leave the match for any reason, an acting captain must be immediately designated and that replacement captain must wear the band.
- 1064.6 Players defending a short corner are encouraged to wear a soft face mask or head protection. The player(s) defending the post during a short corner are required to wear a soft face mask or head protection for the duration of the short corner. The face mask must be smooth, rounded, preferably transparent or single-coloured and fit flush with the face.

1065.0 OFFICIALS

All BCSS Field Hockey Provincials will be officiated by Field Hockey BC certified officials.

Officials are prohibited the use VAR, replay or video in evaluating, upholding or reversing an on-field decision. Replay and video can be used when reviewing (an) event(s) for the purposes of discipline.

1066.0

PROVINCIAL CHAMPIONSHIPS

1066.2 BERTHING

1066.2.1 The same berthing process is used for the AA and AAA Provincial Championships.

1066.2.1.1 Each BCSS zone that has an eligible team will be awarded a berth.

1066.2.1.2 Where applicable, the host school will receive a berth.

1066.2.1.3 Four (4) At-large berths will be awarded to the zones with the highest berthing ratio of:

$$\frac{\text{Total Number Schools with Registered Teams}}{\text{Total Number of Eligible Berths}} = \text{Berthing ratio}$$

$$\frac{\text{Total Number Schools with Registered Teams}}{\text{Teams/Zone Berthing Ratio}} = \text{Number of Berths/zone}$$

1066.2.1.4 Remaining berths will be awarded as wildcard berths to the strongest non-qualifying teams at the discretion of the seeding committee using the historical strength of teams/zones.

1066.2.1.5 If a zone does not have an eligible team, that zone’s berth will become a vacant berth. The vacant berth will be awarded to the next eligible zone as per the percentage established by the at-large berths and will be included in the at-large berth allocation.

Should a zone after the awarding of at-large berths, be unable or unwilling to fill a berth, the vacated berth will be included as a wildcard berth.

1066.3

TOURNAMENT STRUCTURE

1066.3.1 The AA & AAA Provincial Tournaments shall each consist of sixteen (16) teams divided into four equal pools.

1066.3.2 At the conclusion of pool play, the top two teams from each pool enter the championship draw while the bottom two teams in each pool will enter the consolation draw as indicated below.

1066.4 The seeding for both the AA and AAA Girls Field Hockey Championship will be determined based on the strength and final zone placement of the qualifying teams no later than 2 days after the conclusion of the zone championships. The committee will use the following structure when determining the seeding.

Pool A	Pool B	Pool C	Pool D
1	2	3	4
6	5	8	7
11	12	9	10
16	15	14	13

BCSS Field Hockey Championship Draw

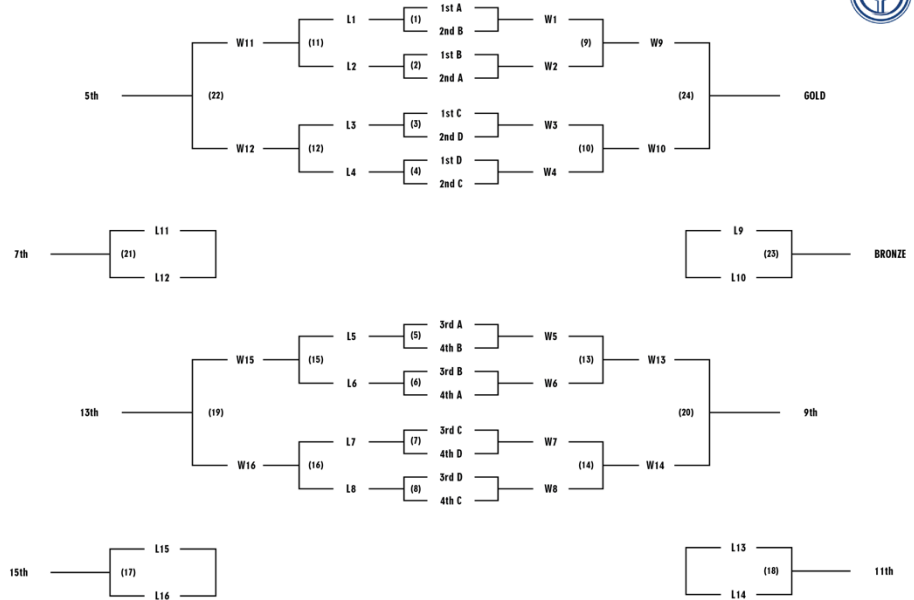

1066.5 TIE BREAK PROCEDURE

1066.5.1 If two teams have the same number of points after pool play is completed then:

- The winner of the match played between those teams shall be awarded the higher placing
- The two teams tied the head-to-head round robin match, then the teams with the higher goal differential (goals for - goals against) throughout round-robin matches shall assume the higher position.
- If the tied teams have the same goal differential, then the team having the least number of goals against in round robin play shall be awarded the higher position.
- If the teams remain tied, the team with the most wins in round robin play shall be awarded the higher position
- If the teams remain tied, it will be settled by a shoot-out, at a time to be determined by the Tournament Director.

If three or more teams have the same number of points at the completion of pool play then the following procedure will be applied in sequential order. If after any step, all tied teams have clear placings, they assume that position and the process is complete. If applying any step of the procedure leads to a breaking of the tie for one, but not all teams, then the team shall be awarded the appropriate placing, and the remaining tied teams shall continue to the next step in the procedure.

- The teams will be awarded placings based on the best goal differential, as defined in 10b, among ONLY THE TIED TEAMS.
- If the teams remain tied, then the team(s) having the least number of goals against among ONLY THE TIED TEAMS shall be awarded the higher position.

- If the teams remain tied, then the team(s) having the most wins among ONLY THE TIED TEAMS, shall be awarded the higher position.
- If the teams remain tied, then the team(s) with the best goal differential in ALL round-robin games shall be awarded the higher position.
- If the tied teams remain tied, then the team(s) having conceded the least number of goals against in ALL round robin opponents will be awarded the higher position.
- If there still remains equality among more than two teams, then each team will play a shoot-out competition against the other teams in the same sequence of play as per the order of play in the tournament, but with 5 (five) shoot-out attempts only to be taken compulsorily by each team. A ranking will then be established based upon the results of the shoot-out only, with the award for each play of 3 points to the team having scored or been awarded the highest number of goals, 1 point to each team having scored or been awarded an equal number of goals and 0 points to the team having scored or been awarded the lowest number of goals.

1066.6 AWARDS (PER TIER)

- BCSS Blue Provincial Championship Banner
- 18 medals for each of the bronze (3rd), silver (2nd), and gold (1st) finishing teams
- Fair Play Award to 1 team

1067.0 CHAMPIONSHIP FACILITY HOSTING REQUIREMENTS

The host is required to have access to a minimum of four (4) regulation size fields. These fields do not need to be on a single site but must be relative in proximity to one another. Zone and Provincial Championships may be played on a synthetic or water-based turf field, or a comparable quality grass field.

1070.0 FOOTBALL

Year	Maximum Number of Playing Days	First Day of Play	Minimum Practices before First Game	Maximum Contact Days/Week	Last Day of Play	Minimum Numbers	Season of Play
2021/22	15	Mon -Week 6	8	3	Sat -Week 18	19	Fall
2022/23	15	Mon- Week 6	8	3	Sat- Week 18	19	Fall
2023/24	15	Mon -Week 6	8	3	Sat- Week 18	19	Fall

1072.0 RULES

The rules governing BCSS Football shall follow that of the National Federation of State High School Associations (NFHS).

1074.0 STUDENT-ATHLETE SAFETY

- 1074.1 Each team must have a person, who is not the Head Coach, who is at minimum has received the Sports Aid Certificate from Sport Med BC. Equivalent or advanced qualifications are also acceptable.
- 1074.2 Coaches must complete the NCCP Safe Contact Coaching certification prior to be on the field as a coach with student-athletes in a practice or competition setting
- 1074.3 Member Schools are required to have students and their parents/guardians sign and return to their school the Concussion Information Sheets prior to participating each season. The school must maintain these returned forms and be able to produce them if requested.
- 1074.4 Each Member School is responsible for following the manufacturer guidelines for re-certification and proper fitting of helmets
- 1074.5 Contact in practice is classified in the following 5-level continuum.

Level 1 – Air	Level 2 - Bags	Level 3 – Control	Level 4 – Thud	Level 5 - Live
Players run drills unopposed with no contact.	Players run drills against bags or another soft contact surface.	Drill is run at an assigned speed until the point of contact. Winner is pre-determined by the coach. Contact is above the waist only and players stay on their feet.	Drill is run at assigned speed (including full speed) through the moment of contact, no predetermined winner. Contact remains above the waist; players stay on their feet and a quick whistle ends the drill.	Drill is run in game-like conditions. This is the only level where players go to ground.

- 1074.7 Starting in BCSS Week 6, any student-athlete is limited to no more than 3 practices per week that includes ‘full contact’. Full contact is defined as contact levels 4 (“Thud”) and 5 (“Live”). Full contact is limited to no more than 30 minutes in one day and therefore, limited to 90 minutes per week.
- 1074.7 A member school may choose to run twice-daily practices prior to week 6. However, only one session per day can include full contact. The non-contact practice shall be non-padded (helmets only).
- 1074.8 Each student-athlete is limited to participating in no more than six (6) quarters per week. A week refers to the 7-day period, running Monday to Sunday, as identified by the BCSS Calendar. One quarter refers to a player playing both offense and defense during that quarter. A player playing offense or defense only during that quarter would be considered as playing one half of a quarter. One night must pass between games where a player plays both offence and defense.

1075.0 OFFICIALS

All officiating at BCSS Football events will be performed by officials provided by the BC Football Officials Association

1076.0 PROVINCIAL CHAMPIONSHIPS

1076.1 BERTHING

1076.1.1 Each January, the Football SAC in collaboration with the staff will evaluate the programs who intend on fielding teams the following year to determine the structure and berthing of championships. After evaluation, discussion and consultation of the coaches, the SAC will make a recommendation no later than the end of March to the Team Championships Committee with a recommendation for the structure of the football championships in both the AA and AAA classification for the following year. The Team Championship chair will bring the recommendation to the Legislative Assembly for approval.

For example, based on recent history, the championship berthing may look like:

AA BCSS Football Provincial Championship Playoff Berthing

- The AA playoff consists of a 12-teams
- The playoff teams will be determined by their placing in their conference based on regular season play
- The following conferences are awarded berths:
 - West Conference – 4 berths
 - East Conference – 4 berths
 - Interior Conference – 2 berths
 - North Conference – 2 berths

And For example, the AAA BCSS Football Provincial Playoffs may look like:

- The AAA playoffs consists of 14 teams
- The playoff teams will be determined by their placing in their conference based on regular season play
- The following conferences are awarded berths:
 - Western Conference – 6 berths
 - Eastern Conference – 6 berths
 - Pacific Conference – 2 berths

1076.2 TOURNAMENT STRUCTURE & SEEDING

1076.2.1 The recommendation will not only include berthing, but a proposed playoff bracket and schedule of dates as well.

As an example, based on recent history, the AA draw may look like the following, but is subject to change at the recommendation of the Football SAC:

BCSS AA FOOTBALL PLAYOFF STRUCTURE

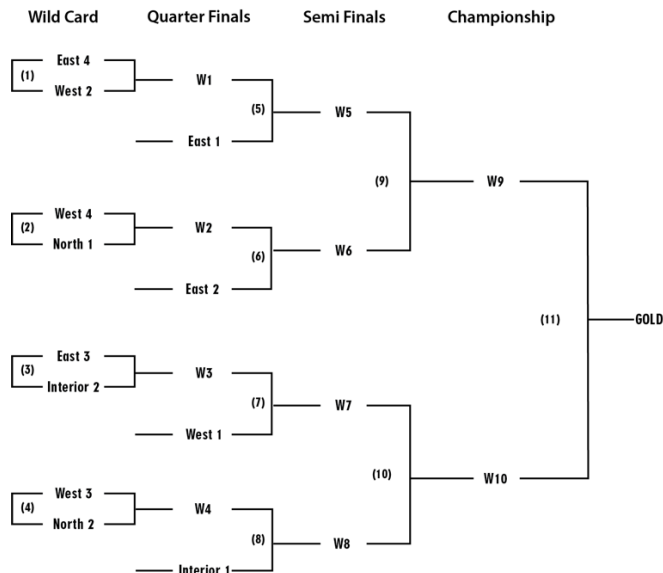

1076.2.2 AAA

The AAA Playoff, based on recent history, may look like the following, but is subject to change based on the evaluation and recommendation of the SAC.

BCSS AAA FOOTBALL PLAYOFF STRUCTURE

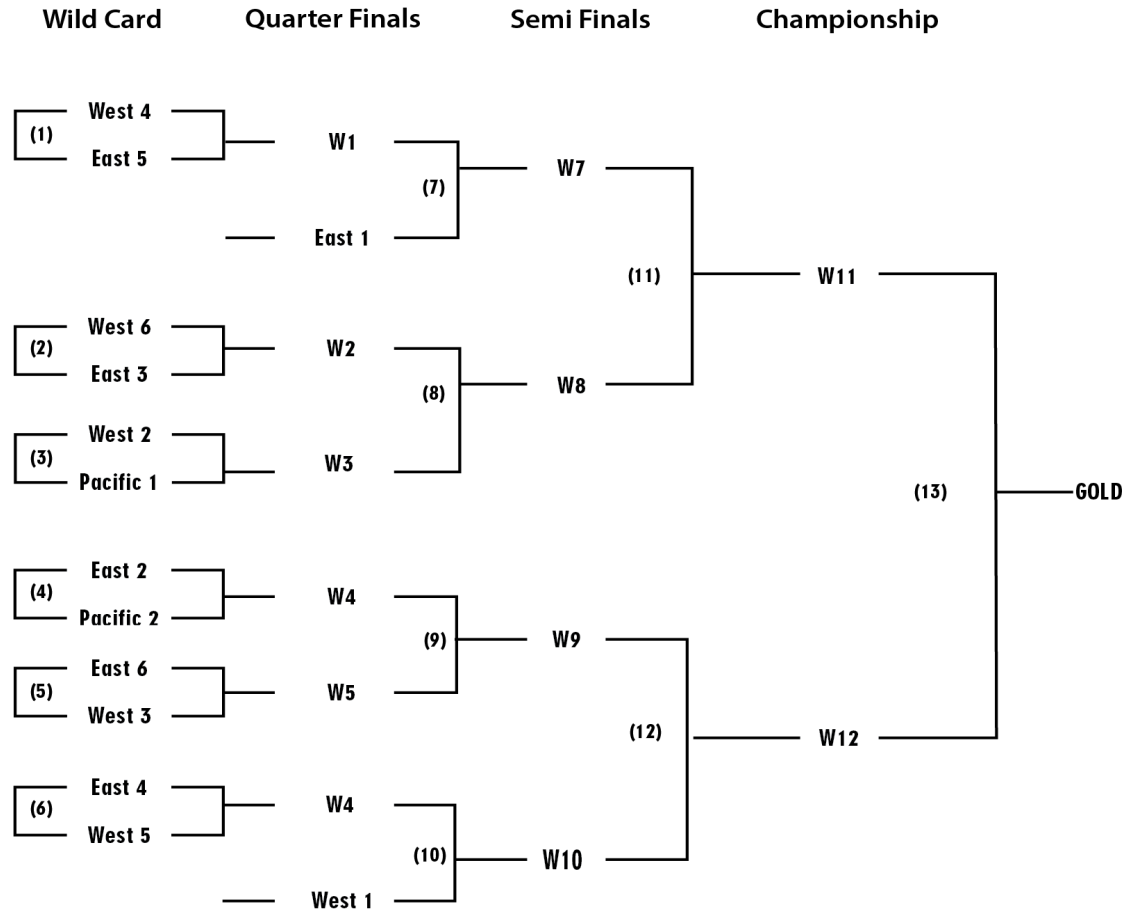

1076.4 TIE BREAK PROCEDURE

If any regular season or playoff game is tied at the conclusion of regulation time. The game will enter a Kansas City Shootout Overtime which will be executed by the game officials as the following:

- A coin toss will determine which side shall attempt to score first, and which end zone the scores shall be attempted
- Each team will receive one-possession, starting with first-and-10 from the 10-yard line on the opponent's end of the field
- The Play Clock will run as normal, there is no game clock, all play is otherwise untimed
- A team's possession ends when it scores, misses a field goal, or turns the ball over (on downs, or by the defense gaining possession)
- If the defense takes possession at any time on an interception or fumble, the play is dead. The defense cannot return a turnover for a score.
- If a touchdown or field goal is scored by the offense take the field first, the defensive team has their chance to match or beat the points gained
- There is no limit to overtime periods, and the process will be repeated until at the end of an equal number of possessions the score is no longer tied

- No extra point is attempted if the winner of the game has been determined

1077.0 AWARDS

BCSS will provide the following team and individual awards:

- BCSS AA Championship Banner
- BCSS AAA Championship Banner
- Conference All Stars
- Provincial All Stars
- Skyline Riddell Helmet Awards
- AA/AAA Offensive and Defensive Player of the year

1078 SPRING SEASON

A school team may meet another team or participate in a jamboree with several school teams on one occasion between February 1 and the end of the school year. The spring game/jamboree should be scheduled in conjunction with spring practices. A player must meet the minimum number of practices required before participating in interschool play. Practices prior to February 1st do not count toward the minimum number of practices.

1081.0

Year	Number of Contest Dates	First Day of Play	Last Day of Play	Minimum Numbers	Maximum Roster	Season of Play
2021/22	15	Mon- Week 31	Sat- Week 45	4	5	Spring
2022/23	15	Week	Week	4	5	Spring
202/24	15	Week		4	5	Spring

1082.0
RULES

The rules governing BCSS Golf shall follow those of the Royal Canadian Golf Association (RCGA).

1083.0
RULE MODIFICATIONS

- 1083.1 Electronic Devices
Competitors are not allowed the use of electronic communication devices during tournament play, cell phones or other electronics cannot be used as a measuring device
- 1083.2 Motorized Golf Carts
No competitors shall be permitted to use motorized golf carts unless with the express permission from the Championship Host Committee and BC School Sports.
- 1083.3 Losing a Player
A team may have no fewer than four (4) players, but no more than five (5). Every team will count their lowest four scores on each day of competition.
- 1083.4 Co-Ed Teams
BCSS Golf is a co-ed sport, and schools may have any gender composition on their roster. There are no gender specific requirements to field a BCSS Golf team. Student-athletes who identify as female will play from the designated forward tee markers.
- 1083.5 Caddies are not permitted

1084.0
OFFICIALS

All tournaments will be self-officiated by players; BCSS may employ tournament officials at their discretion

1085.0
EQUIPMENT

All schools competing must be identifiable by dress – all members from any given school must wear the same colour shirts and if possible, slacks to match. Any competitors wearing shorts must have proper Bermuda style shorts, measuring no more than 3 inches above the knee.

1085.0
COMPETITIONS

- 1085.1 EVENTS
- AAA – 22 teams (21 berths plus host school berth)
 - AA - 18 teams (17 berths plus host school berth)
 - A - 10 teams (9 berths plus host school berth)

- 1085.2 BERTHING

Each zone will receive one automatic berth to each BCSS Golf Championship. The remaining berths to a BCSS championship are awarded based on the numbers-based allocation formula determined by BC School Sports. A member school may only qualify one team to zone or provincial championships.

$$\frac{\text{Total Number Schools with Registered Teams}}{\text{Total Number of Eligible Berths}} = \text{Berthing ratio}$$

* If a zone does not have any eligible teams; that berth will not be reallocated as a full championship composition isn't necessary for the sport of golf*

$$\frac{\text{Total Number Schools with Registered Teams}}{\text{Teams/Zone Berthing Ratio}} = \text{Number of Berths/zone}$$

1085.3 STRUCTURE

The Championships will consist of a 2 day event, with 18-holes being played each day. The team with the low total score for 36 holes total shall be Provincial Champions.

1085.4 FOURSOMES & TEE-TIMES

- No two (2) players representing the same school shall be in the same foursome
- For the first round, golfers will be placed according to team placement (Eg: Number 1 golfers play together)
- For the 2nd day of the championship, golfers will be placed according to their first day team totals with #1 golfers playing with each other etc.
- Whenever possible, Tee times for the 2nd round should be an early morning shot gun start to allow time for travel.
- One coach from each school will be included on the tee sheet on Day 1 of the competition and will tee off in front of or behind their team. Any other coach associated with that team may be accommodated where they can fit into the draw.
- Only student-athletes are allowed to play on the 2nd day of the championship. No Coaches or other guests are permitted to participate without permission of the tournament director or BC School Sports.

1085.4 TIE BREAK PROCEDURE

- Ties for the individual and team honours shall be decided by a sudden death play-off at the conclusion of the final round.
- In the case of a team play-off, the four (4) scores counted on the final day will be the 4 players who go into the play-off. The team with the least number of total strokes on the hole being played shall be declared the winner.
- Ties for second through sixth will be settled using the tie-breaking system of the RCGA, Golf Canada & Golf BC.

1086.0 AWARDS

Gold, Silver and Bronze (6 of each) medals will be awarded to the three teams with the lowest gross score for 36 holes. The BCSS Championship Banner will be presented to the team with the lowest gross score for 36 holes.

1087.0 CHAMPIONSHIP HOSTING REQUIREMENTS

BCSS recognizes that most member schools do not have the facilities to host a Golf Championship, and therefore need to book 3rd party facilities to host the championships. The facility chosen as the host location for the championship must abide by the up-to-date Royal Canadian Golf Association minimum standard course guidelines.

If your school plans on submitting a bid to host a BCSS Gold Championship and wants clarification on if your chosen facility has all of the requirements, please reach out to the BCSS office for further clarifications

1088.0**BCSS GOLF COURSE ETTIQUITE**

- No advice is to be given to a player during a tournament or championship
- Avoid all communication, verbal and non-verbal which may be construed by others as advice
- Keep your distance from the competitors (approximately 75 yards) while following them during play
- Do not walk on the fairway during tournament/championship rounds
- Players must not distract competitors on the golf course

Non-compliance may result in a two-shot penalty assessed to the competitor receiving advice and/or the removal of the advisor from the golf course

1090.0 Gymnastics

*These rules are included as a placeholder in the 2021-2022 handbook, over the summer rules will be finalized by the BCSS office and brought to a vote by the Legislative Assembly at the Fall Planning Meeting in October.**

1091.0

Year	Max number of playing days	First Day of Play	Last Day of Play	Minimum Numbers	Season of Play
2021/22	15	Mon - Week 18	Sat- Week 29	1	Winter
2022/23	15	Mon – Week	Sat- Week	1	Winter
2023/24	15	Mon – Week	Sat- Week	1	Winter

1092.0 RULES OF PLAY

The rules of play governing BCSS Gymnastics shall follow those of USA Gymnastics JO Optional Exercises CoP with the following modifications:

1092.1 Level qualifications

1092.1.1 GIRLS LEVELS

- **Level I (JR/SR)**
 - A Gymnast with little to no previous experience, including beginner recreational gymnasts
 - A gymnast that competed in Level I the previous season and did not place in the top six all-around
 - A club gymnast training or competing in JO level 1-3
- **Level II**
 - A Gymnast with previous experience or training as a recreational athlete in a gymnastics club
 - A gymnast who placed in the top size all-around in the previous year's provincial championship in level I
 - A gymnast that competed in Level II the previous season and did not place in top six all-around
 - A club gymnast training or competed in JO level 4 must compete Level II or higher
- **Level III**
 - A gymnast with previous experience training beyond a recreational level
 - A gymnast who placed in top size all-around in the previous year's provincial championship in level II
 - A gymnast that competed in Level III at the previous year's provincial championship and did not place in top size all-around
 - A club gymnast training or competing in JO Level 5 or 6 must compete Level III or higher
- **Level IV**
 - A gymnast who placed in the top 3 all-around in the previous year's provincial championship in level III
 - A gymnast that competed in Level IV the previous season, regardless of final placement in the previous provincial championship
 - A club gymnast training or competing in JO Level 7
 - A club gymnast that has competed in CPP Level 3 prior to the first day of the current school year
- **Level V**
 - A club gymnast training or competing in JO Level 8 or higher
 - A gymnast that has competed in CPP Level 4 or 5 after the first day of the current school year, or at a higher level at any time

1092.1.2 BOYS LEVELS

- **Level I**
 - A Gymnast with little to no previous experience, including beginner recreational gymnasts
 - A gymnast that competed in Level I the previous season and did not place in the top six all-around
 - A club gymnast training or competing in JO level 1-3
- **Level II**
 - A Gymnast with previous experience or training as a recreational athlete in a gymnastics club
 - A gymnast who placed in the top three all-around in the previous year's provincial

- championship in level I
- A gymnast that competed in Level II the previous season and did not place first in all-around
- A club gymnast training or competed in JO level 4 must compete Level II or higher
- **Level III**
 - A gymnast with previous experience training beyond a recreational level
 - A gymnast who placed first all-around in the previous year's provincial championship in level II
 - A gymnast who is ready to compete in Level III Skills (as determined by the coach)
 - A gymnast that competed in Level III in the previous year and did not place first all-around
- **Level IV**
 - A gymnast who placed first all-around in the previous year's provincial championship in level III
 - A gymnast that competed in Level IV the previous season, regardless of final placement in the previous provincial championship
 - A gymnast who is ready to compete in Level IV skills (as determined by the coach)
 - A club gymnast that has competed in CPP Level 4 prior to the first day of the current school year
- **Level V**
 - A gymnast who is ready to compete in Level V skills (as determined by the coach)
 - A gymnast that has competed in CPP Level 4 or 5 after the first day of the current school year, or at a higher level at any time

1092.2 Repetition of an Exercise

A vault, bars, beam, or floor routine may be repeated only in case of technical malfunctions that are beyond the control and responsibility of the athlete and coach. It is the decision of the head judge of the particular apparatus to decide, upon request of the gymnast's coach. The gymnast may request to see the score of her first routine before deciding if she is going to repeat. The request must be made immediately after the malfunctions.

1093.0 EQUIPMENT

- All athletes must wear a school team gymnastics body suit (long or short sleeve), gymnastics shoes and grips (optional). Tights may be worn if they are no longer than thigh length and match the colour and material of the body suit.

1094.0 OFFICIALS

Officials and Judges at the BCSS Gymnastics Provincial Championship will be those of BC Gymnastics and the Gymnastics Community with the appropriate certification based on the level to which they are judging. Judges must have a minimum certification of JO 5 to be eligible to judge at the BCSS Gymnastics Provincial Championship

1095.0 COMPETITIONS

1095.1 EVENTS

1095.1.1 The following events with the below standards will be contested in the girls category :

- Vault

Value Parts	LEVEL 1		LEVEL 2		LEVEL 3		LEVEL 4		LEVEL 5	
	Max Start Value: 10.0									
1 or 2 Vaults, Best to Count										
VAULTS ALLOWED	Jump to handstand to back on stacked mats, beat board only	9.0	Jump to handstand to back on stacked mats, beat board only	8.5	Handspring/ Yamashita	9.8	Handspring/ Yamashita	9.5	Handspring	9.0
	Tuck/Straddle through, beat board only	9.0	Tuck/Straddle through, beat board only	8.5	Handspring/ Yamashita - ½ twist off	10.0	Handspring/ Yamashita - ½ twist off	9.8	Handspring - 1/2	9.1
									Handspring - 1/1	9.5
									Handspring - 1 1/2	9.7
									Handspring - 2/1	10.0
	Tuck/Straddle through, layout position, beat board only	10.0	Tuck/Straddle through, layout position, beat board only	9.0	½ on - repulsion (w/ flight to feet) off	9.8	Handspring/ Yamashita - 1/1 twist off	10.0	1/4-1/2 on - repulsion (w/ flight to feet) off	9.0
									1/2 on - 1/2 off	9.2
									1/2 on - 1/1 off	9.4
									1/2 on - 1 1/2 off	9.6
									1/2 on - 2/1 off	10.0
Yurchenko - repulsion (w/ flight to feet) off									9.0	
Handspring with mini tramp or "doubled" beat-boards	10.0	Handspring with mini tramp or "doubled" beat-boards	9.5	½ on - ½ turn off	9.8	½ on - repulsion (w/ flight to feet) off	9.5	Yurchenko - repulsion off	9.1	
								Yurchenko - 1/1	9.4	
								Yurchenko - Back tuck	9.8	
								Yurchenko - Back pike	10.0	
Handspring with mini tramp or "doubled" beat-boards	10.0	Handspring with beat board only	10.0	½ twist on - ½ twist off	10.0	½ twist on - 1/1 twist off	10.0	Tsukahara - Tuck	9.8	
									Tsukahara - Pike	10.0
EQUIPMENT	Min. height for all vaults 110cm (Max. height 125 cm)		Min. height for all vaults 110cm (Max. height 125 cm)		Min. height for all vaults 120 cm (Max. height 125 cm)		Height for all vaults - 125 cm		Height for all vaults - 125 cm	
	Mandatory min 10 cm matting for landing. Otherwise, any mat or combination of mats, including 20 cm safety mat is allowed. An approved Yurchenko collar must be used for all round-off entry vaults. A beat-board may be used for the last step before a handspring with mini tramp vault.									

• Uneven Bars

	Level 1	Level 2	Level 3	Level 4	Level 5
Value Parts (VP)	6 Supp. or A's Start Value: 10.0 Supp. & A Elements Only	6 A's Start Value: 10.0 (Maximum 3 supplemental A's)	6 A's Start Value: 10.0 A & B Elements Only (Only JO skills allowed)	6 A's, 1 B Start Value: 10.0 Allowable C Elements Permitted Only JO skills allowed)	4 A's, 4 B's Start Value: 10.0 A, B, & C+ Elements (Only JO skills allowed)
Restrictions	No B+ No Salto Restricted elements = no Value Part credit and 0.50 deduction from SV	No B+ No Salto Restricted elements = no Value Part credit and 0.50 deduction from SV	No C+ Restricted elements = no Value Part credit and 0.50 deduction from SV	Allowable C's credited as B C elements not "allowable" - considered restricted elements Restricted elements = no Value Part credit and 0.50 deduction from SV	C+ elements credited as B No restrictions on difficulty
Special Requirements (SR)	<ul style="list-style-type: none"> Pullover (feet together or apart) Swing element (beat, long, or glide) One cast to feet at bar height Minimum of one bar change Dismount 	<ul style="list-style-type: none"> Low bar pullover (feet together or apart) or kip One cast to feet at bar height Squat on (tuck/pike/straddle) to catch high bar Long hang swing element (long kip, long swing & counter swing, or long swing pullover) Dismount 	<ul style="list-style-type: none"> One cast to a minimum of horizontal Minimum of one bar change LB to HB Two different circling elements from Group 3, 6, or 7 Dismount Minimum of 'A' 	<ul style="list-style-type: none"> One cast to a minimum of 45° from vertical One clear circling element, minimum of 'B' Salto Dismount Minimum of 'A' 	<ul style="list-style-type: none"> Minimum of one bar change Two "B" elements: <ul style="list-style-type: none"> i. Two different 360° clear circling "B" elements or ii. One 360° clear circling "B" element from and one "B" element with either flight or a minimum of 180° long axis turn (excluding dismount) Salto Dismount Minimum of 'A'
Equipment	<p>BAR HEIGHT: Low Bar – 170 cm from floor (150 cm from top of mat), High Bar – 250 cm from floor (230 cm from top of mat). NOTE: A beat board may be used for any mount – to be removed as soon as mount is completed. Otherwise, a 0.3 deduction will be applied. Mandatory 10 cm matting for landing of dismount. Otherwise, any mat or combination of mats, including a 20 cm safety mat, is allowed for dismount. Presence of coach on mats is allowed.</p>				

• Balance Beam

	Level 1	Level 2	Level 3	Level 4	Level 5
Value Parts (VP)	6 Supp. or A's Start Value 10.0	6 A's A Elements Only (Max. 2 supp.)	5 A's, 1 B A & B Elements Only (Only JO COP)	5 A's, 2 B's A & B Elements Only (Only JO COP)	4 A's, 4 B's A, B, & C+ Elements (Only JO COP)
Restrictions	No B+ Acro elements Dance B's or C's credited as A No Salto/aerial DMT Restricted elements = no Value Part credit and 0.50 deduction from SV	No Handspring, saltos or aerials Dance B's or C's credited as A Restricted elements = no Value Part credit and 0.50 deduction from SV	No C+ Acro Dance C's credited as B Restricted elements = no Value Part credit and 0.50 deduction from SV	No D+ Acro Dance C's credited as B Restricted elements = no Value Part credit and 0.50 deduction from SV	No restrictions on difficulty C+ elements credited as B D+ Acro/Dance Elements credited as C
Special Requirements (SR)	<ul style="list-style-type: none"> ½ turn on one foot (<i>pirouette en dedans</i>) Two different dance elements – if missing one or both -0,50 Acro A element (can be supplemental) DMT <p><i>* if gymnast is turning on L foot then turn is to the L (or vice versa)</i></p>	<ul style="list-style-type: none"> Minimum 360° turn on one foot Two different dance elements – one being leap/jump with min. 90° split – cross or side.** One Acro A Minimum A value DMT 	<ul style="list-style-type: none"> Minimum 360° turn on one foot. One leap/jump with minimum 120° split – cross or side.** Acro series of 2+ A elements. Min A+ DMT 	<ul style="list-style-type: none"> Minimum 360° turn on one foot. One leap/jump with minimum 180° split – cross or side i. Acro series (2 elements with or without flight; excluding mount & dismount) and ii. An acro flight element if not included in the series if missing one or both – 0,50 Minimum 'A' Dismount (Aerial or Salto) 	<ul style="list-style-type: none"> One leap or jump with a 180° split (cross or side) Acro series (2 elements, excluding mount & dismount), with minimum one of the two being flight Minimum of a 360° turn on one foot Minimum 'A' Dismount (Aerial or Salto)
Equipment	<p>BEAM HEIGHT: 125 cm. TIME: Levels 1 & 2 - Minimum 30 seconds, 1:15 max; Levels 3, 4, & 5 – Minimum 30 seconds, 1:30 max. Time begins when the gymnast's feet leave the ground to mount and ends when the gymnast touches the mat upon completion of the exercise. A warning signal will be given 10 seconds before the maximum time limit of the respective exercise. NOTE: A beat board may be used for any mount – to be removed as soon as mount is completed. Otherwise, a 0.3 deduction will be applied. Mandatory 10 cm matting for landing of dismount. Otherwise, any mat or combination of mats, including a 20 cm safety mat, is allowed for dismount.</p>				

• Floor Exercise

	Level 1	Level 2	Level 3	Level 4	Level 5
Value Parts (VP)	6 Supp. or A's Start Value 10.0 Supp. & A Elements Only	6 A's Start Value 10.0 A Elements Only	5 A's, 1 B Start Value 10.0 A & B Elements Only	5 A's, 2 B's Start Value 10.0 A & B Elements Only	4 A's, 4 B's Start Value 10.0 A, B, & C+ Elements
Restrictions	No handsprings/saltos/aerials Dance B's or C's credited as A Restricted elements = no Value Part credit and 0.50 deduction from SV	No saltos or aerials Dance B's or C's credited as A Restricted elements = no Value Part credit and 0.50 deduction from SV	No C+ Acro Dance C's credited as B Restricted elements = no Value Part credit and 0.50 deduction from SV	Dance C's credited as B Restricted elements = no Value Part credit and 0.50 deduction from SV	C+ elements credited as B No restrictions on difficulty
Special Requirements (SR)	<ul style="list-style-type: none"> Acro series with 2 elements directly connected Momentary handstand within 10° of vertical (return position optional) 360° turn on one foot Dance series/passage with a minimum of 2 different elements, directly or indirectly connected Mixed series of an acro element directly connected to a non-hold dance element (or vice versa) 	<ul style="list-style-type: none"> Acro series with 3 elements directly connected (one of which includes flight) or 2 directly connected flight elements Handstand (marked position) to forward roll with straight arms or Straight arm backward roll 360° turn on one foot Dance series/passage with a minimum of 2 different elements, directly or indirectly connected - one of which is an element with a 120° cross or side split Mixed series of an acro element directly connected to a non-hold dance element (or vice versa) 	<ul style="list-style-type: none"> Acro series of 2+ acro flight elements, two being BWD elements directly connected Acro series of 2+ acro flight elements, two being FWD elements directly connected (different from above SR) One salto or aerial in one of the above acro series Minimum of a 360° turn on one foot Dance passage with a minimum of 2 different elements, directly or indirectly connected - one of which is a leap with a 180° cross or side split 	<ul style="list-style-type: none"> An acro series with 3 directly connected flight elements, one of which is a back layout salto An acro series with 2 or more directly connected forward acro elements with flight, one being a salto or aerial Minimum of a 360° turn on one foot Dance passage with a minimum of 2 different elements, directly or indirectly connected - one of which is a leap requiring a 180° cross or side split Salto/Aerial FWD/SWD and BWD 	<ul style="list-style-type: none"> An acro series with 2 saltos or 2 directly connected saltos (same or different) Three different saltos (not aerials) within the exercise Dance passage with a minimum of 2 different elements, directly or indirectly connected - one of which is a leap with 180° cross or side split Salto/Aerial FWD/SWD and BWD Dismount Minimum 'A' salto
Equipment	Up to 10 cm of additional matting allowed for acro lines with salto. The additional mat may be left in place, moved, or removed. TIME: Levels 1 & 2 - Minimum 30 seconds, 1:15 max; Levels 3, 4, & 5 – Minimum 30 seconds, 1:30 max. Timing begins with the first movement of the gymnast.				

1095.1.2 The following events and standards will be contested in the boys category:

• Floor Exercise

Levels 4 and 5 must use the entire floor area, represented by arriving in each corner at least once.

	Level 1	Level 2	Level 3	Level 4	Level 5
Start Value	Max. 6 counting skills (A=0.1) Special Req. +0.5 ea. Execution 10.0 Maximum D-Score 3.1 <i>Plus Stuck Landing Bonus</i>	Max. 6 counting skills (A=0.1, B=0.2) Special Req. +0.5 ea. Execution 10.0 Maximum D-Score 3.4 <i>Plus Stuck Landing Bonus</i>	Max. 7 counting skills (A=0.1, B=0.2, C=0.3) Special Req. +0.5 ea. Execution 10.0 Maximum D-Score 3.7 <i>Plus Stuck Landing Bonus</i>	Max. 6 counting skills with values as per FIG CoP Canadian Provincial Pathways Level 3 Rules Maximum D-Score 3.7 <i>Plus Landing & Virtuosity Bonus</i>	Max. 7 counting skills with values as per FIG CoP Canadian Provincial Pathways Level 4 Rules Maximum D-Score 4.0 <i>Plus Landing & Virtuosity Bonus</i>
Special Requirements	I) An acrobatic series; min. 2 elements II) Cartwheel or roundoff III) One balance or hold element IV) Forward or backward roll V) Acrobatic dismount that lands on the feet or roundoff directly connected to a jump	I) An acrobatic series; min. 3 elements II) Second acrobatic series; min. 2 elements III) One balance or hold element IV) Front or back handspring V) Acrobatic dismount that lands on the feet	I) An acrobatic series; min. 3 elements II) Second acrobatic series; min. 2 elements III) One balance or hold element IV) Salto element V) Acrobatic dismount that lands on the feet	2 FIG Element Groups FIG A(+0.5 ea.) Supplemental A(+0.3 ea.) Front Handspring or Flyspring(+0.5) A Dismount (+0.5) Supplemental A Dismount(+0.3)	2 FIG Element Groups FIG A(+0.5 ea.) Supplemental A(+0.3 ea.) Back Layout Full Twist or more(+0.5) A Dismount (+0.3) B Dismount (+0.5)
Additional Regulations	•No time limit •Any one skill may be performed twice for value. •NO Saltos (1.0 deduction) •NO back handsprings (1.0 deduction)	•No time limit •Any one skill may be performed twice for value. •NO Saltos (1.0 deduction) •Roundoff back handspring back handspring counts as "ABB"	•No time limit	•70 sec. time limit •+0.5 bonus for each additional Element Group requirement •Salto connection bonus: (A+B or C), (B+B or C) = +0.1 (C+C), (D+A or greater) = +0.2 •Up to +0.2 virtuosity bonus	•70 sec. time limit •+0.5 bonus for each additional Element Group requirement •Salto connection bonus: (A+B or C), (B+B or C) = +0.1 (C+C), (D+A or greater) = +0.2 •Up to +0.2 virtuosity bonus
	"A" Skills	"B" Skills	"C" Skills		
	<ul style="list-style-type: none"> Forward roll Backward roll Roundoff Dive-roll Cartwheel Headspring 	<ul style="list-style-type: none"> Front handspring Back handspring Front handspring to dive roll (2 B's) Front handspring to handspring (2 B's) Flyspring Arabian dive-roll 	<ul style="list-style-type: none"> Front tuck Front pike Front layout Arabian salto Front handspring flyspring (1 C) Two consecutive backhandsprings (1 C) Back tuck Back pike Back layout Side somersault/aerial 		
	Non-Acrobatic Skills	Non-Acrobatic Skills	Non-Acrobatic Skills		
	<ul style="list-style-type: none"> L-sit [2 sec.] Windmill Any jump or leap Headstand [2 sec.] Prone fall Pike sit [2 sec.] Momentary handstand Single-leg circle Any scale [2 sec.] Pike press to stand 	<ul style="list-style-type: none"> V-sit [2 sec.] Double-leg circle Kip to stand Any split (180°) [2 sec.] Headstand push to handstand [2 sec.] Back roll to handstand (back extension) Front/Back walkover Flair Handstand [2 sec.] 	<ul style="list-style-type: none"> Two double-leg circles Press to wide-arm handstand [2 sec.] V-sit press to handstand [2 sec.] (2 C's) Y-scale with 180° split [2 sec.] Press to handstand [2 sec.] Two flairs 		

• Pommel Horse

Levels 1, 2, and 3 must use the pommel horse with the pommels. Levels 4 and 5 have the option of using the pommel horse without pommels. All levels may use a spring board to mount. Level 4 Only: Athletes have the option of using a mushroom, however, if they choose to use the pommel horse with pommels, they may use any skill listed below and receive a supplemental "A" part and 0.3 for Element Group..

	Level 1	Level 2	Level 3	Level 4	Level 5
Start Value	Max. 6 counting skills (A=0.1, B=0.1) Special Req. +0.5 ea. Execution 10.0 Maximum D-Score 3.1 Plus Stuck Landing Bonus	Max. 6 counting skills (A=0.1, B=0.2, C=0.2) Special Req. +0.5 ea. Execution 10.0 Maximum D-Score 3.4 Plus Stuck Landing Bonus	Max. 7 counting skills (A=0.1, B=0.2, C=0.3) Special Req. +0.5 ea. Execution 10.0 Maximum D-Score 3.7 Plus Stuck Landing Bonus	Max. 6 counting skills with values as per FIG CoP Canadian Provincial Pathways Level 3 Rules Maximum D-Score 3.7 Plus Landing & Virtuosity Bonus	Max. 7 counting skills with values as per FIG CoP Canadian Provincial Pathways Level 4 Rules Maximum D-Score 4.0 Plus Landing & Virtuosity Bonus
Special Requirements	I) Leg cut forwards II) Leg cut backwards III) Any pendulum swing IV) Any travel element V) Dismount • A or B dismount = +0.5; • Any non-listed but recognized dismount = +0.3	I) Single-leg circle forward or backward II) Any scissor element III) Any pendulum swing IV) Any travel element V) Dismount • A, B, or C dismount = +0.5; • Any non-listed but recognized dismount = +0.3	I) Single-leg circle forward or backward II) Any scissor element III) Any double-leg circle element IV) Any travel element V) Dismount • A, B, or C dismount = +0.5; • Any non-listed but recognized dismount = +0.3	2 FIG Element Groups FIG A(+0.5 ea.) Supplemental A(+0.3 ea.) Flair Element(+0.5) A Dismount (+0.5) Supplemental A Dismount(+0.3)	2 FIG Element Groups (+0.5 ea.) Any 3/3 Travel(+0.5) A Dismount (+0.3) B or higher Dismount (+0.5)
Additional Regulations	• Any one skill may be performed twice for value.	• Any one skill may be performed twice for value.	• Double-leg circle element group includes 180° Russian and simple Swiss	• Mushroom or horse, with or without handles (any height) • Flair and Circle are considered separate elements • +0.5 bonus for each additional Element Group requirement • Up to +0.2 virtuosity bonus	• Horse, with or without handles (any height) • Flair and Circle are considered separate elements • +0.5 bonus for each additional Element Group requirement • Up to +0.2 virtuosity bonus
"A" Skills	<ul style="list-style-type: none"> Single-leg cut Front support travel (½) Stride swing Rear support swing ½ travel with ½ turn Reverse single-leg cut (½) Single leg travel (½) Pendulum swing 	"B" Skills	"C" Skills		
Dismounts	<ul style="list-style-type: none"> Single leg swing to dismount Flank dismount Wende dismount from side support 	<ul style="list-style-type: none"> 180° Russian or simple Swiss to flank dismount Flank with ½ turn to dismount ("Wende") 	<ul style="list-style-type: none"> Stöckli Moore 360° Russian ½ side travel ½ Magyar ½ spindle in circle or flair Scissor with hop to leather Two consecutive single-leg circles Two consecutive scissors Two consecutive double-leg circles 	<ul style="list-style-type: none"> Downhill loop Two consecutive flairs Scissor with ½ turn ½ Sivado 	

• Still Rings

Note of Caution: Gymnasts performing "dislocates" for the first time should understand that it is important to maintain pressure on the rings throughout the skill. Proceed with caution. In virtually all transition moves from one level to another, for example, support to hands, the gymnast should maintain constant pressure on the rings. Do not allow them to go slack.

	Level 1	Level 2	Level 3	Level 4	Level 5
Start Value	Max. 6 counting skills (A=0.1) Special Req. +0.5 ea. Execution 10.0 Maximum D-Score 3.1 Plus Stuck Landing Bonus	Max. 6 counting skills (A=0.1, B=0.2) Special Req. +0.5 ea. Execution 10.0 Maximum D-Score 3.4 Plus Stuck Landing Bonus	Max. 7 counting skills (A=0.1, B=0.2, C=0.3) Special Req. +0.5 ea. Execution 10.0 Maximum D-Score 3.7 Plus Stuck Landing Bonus	Max. 6 counting skills with values as per FIG CoP Canadian Provincial Pathways Level 3 Rules Maximum D-Score 3.7 Plus Landing & Virtuosity Bonus	Max. 7 counting skills with values as per FIG CoP Canadian Provincial Pathways Level 4 Rules Maximum D-Score 4.0 Plus Landing & Virtuosity Bonus
Special Requirements	I) L-hang or V-hang II) Long hang swing III) Swing to inverted hang IV) Pike inverted hang V) Dismount • A dismount = +0.5; • Any non-listed but recognized dismount = +0.3	I) Any swing element II) L-sit in front support III) Any other strength element IV) Pike or straight inverted hang V) Dismount • A or B dismount = +0.5; • Any non-listed but recognized dismount = +0.3	I) Inlocate or dislocate II) L-sit in front support III) Any other strength element IV) Muscle-up, kip, or back uprise V) Dismount • A, B, or C dismount = +0.5; • Any non-listed but recognized dismount = +0.3	2 FIG Element Groups FIG A(+0.5 ea.) Supplemental A(+0.3 ea.) Cross Support Without Assistance(+0.5) A Dismount (+0.5) Supplemental A Dismount(+0.3)	2 FIG Element Groups (+0.5 ea.) Press to 2 Second Handstand(+0.5) A Dismount (+0.3) B Dismount (+0.5)
Additional Regulations	• Any one skill may be performed twice for value. • Long hang swing may be used as an "A" part	• Any one skill may be performed twice for value. • May be boosted to support without deduction • 2 extra swings allowed	• 2 extra swings allowed	• Up to 40cm landing mats allowed • +0.2 bonus for all "B" or greater strength skills • +0.5 bonus for each additional Element Group requirement • Up to +0.2 virtuosity bonus	• Up to 20cm landing mats allowed • +0.2 bonus for all "B" or greater strength skills • +0.5 bonus for each additional Element Group requirement • Up to +0.2 virtuosity bonus
"A" Skills	<ul style="list-style-type: none"> Skin the cat Inverted pike hang Bail from shoulder stand Inverted hang Tuck to inverted hang Swing to inverted hang 	"B" Skills	"C" Skills		
Strength Elements	<ul style="list-style-type: none"> L-hang (also with bent arms) V-hang (also with bent arms) 	<ul style="list-style-type: none"> L-sit Straddled L-sit Straddled back lever Straight arms bent body pull to inverted hang Straight body bent arms pull to inverted hang 	<ul style="list-style-type: none"> Kip Back uprise Front/back bail from handstand 	<ul style="list-style-type: none"> Straight body inlocate Kip to L-sit (1 C) Any swing handstand Front support bwd/fwd roll to support Back uprise with straight arms Back roll to support with/without swing (Felge) 	<ul style="list-style-type: none"> Dislocate above rings Front Uprise
Dismounts	<ul style="list-style-type: none"> Back pike/tuck/layout Straddle back salto 	<ul style="list-style-type: none"> Front tuck/pike Back uprise salto/tuck/pike ("Koste") Back layout ½ turn 	<ul style="list-style-type: none"> Double back tuck Back layout full turn Front layout 	<ul style="list-style-type: none"> Press handstand Front lever Iron cross 	<ul style="list-style-type: none"> V-sit Back lever Front pike ½ turn Back uprise salto layout

• Vault

All vaults must be performed with a beatboard, except for Level 1, where a mini-tramp or double beatboard may be used for Handspring. All vaults must have a spotter present.

	Level 1	Level 2	Level 3	Level 4	Level 5
Vault Setup	115, 125, or 135cm cross horse or table			110-135cm table	110-135cm table
Special Requirements	3.1 vaults only	3.1 vaults or handspring	Maximum of handspring full turn, minimum of handspring. 1.0 deduction from final score for 3.1 value vaults	All FIG vaults allowed. Maximum awarded D-score of 3.7	All FIG vaults allowed. Maximum awarded D-score of 4.0
Additional Regulations	• 2 nd vault permitted with 1.0 deduction	• 2 nd vault permitted with 1.0 deduction	• 2 nd vault permitted with 1.0 deduction • NO salto vaults	• 2 nd vault permitted with 1.0 deduction • Additional 10cm landing mat permitted	• 2 nd vault permitted with 1.0 deduction • Additional 10cm landing mat permitted
Start Values					
• Layout tuck through				3.1	
• Layout straddle through				3.1	
• Layout stoop through				3.1	
• Handspring (with mini-tramp or double beatboard) Level 1 only				3.1	
• Handspring				3.4	
• Handspring ½ off				3.4	
• Handspring ½ on, ½ off				3.4	
• Handspring full off				3.7	

• Parallel Bars

All Levels may use the bars at any setting up to 10 cm past FIG height, provided that they can still swing in upper arm support. All levels may use a spring board to mount.

	Level 1	Level 2	Level 3	Level 4	Level 5
Start Value	Max. 6 counting skills (A=0.1) Special Req. +0.5 ea. Execution 10.0 Maximum D-Score 3.1 Plus Stuck Landing Bonus	Max. 6 counting skills (A=0.1, B=0.2) Special Req. +0.5 ea. Execution 10.0 Maximum D-Score 3.4 Plus Stuck Landing Bonus	Max. 7 counting skills (A=0.1, B=0.2, C=0.3) Special Req. +0.5 ea. Execution 10.0 Maximum D-Score 3.7 Plus Stuck Landing Bonus	Max. 6 counting skills with values as per FIG CoP Canadian Provincial Pathways Level 3 Rules Maximum D-Score 3.7 Plus Landing & Virtuosity Bonus	Max. 7 counting skills with values as per FIG CoP Canadian Provincial Pathways Level 4 Rules Maximum D-Score 4.0 Plus Landing & Virtuosity Bonus
Special Requirements	I) Back uprise from long hang swing to upper arm or jump to upper arm II) Upper arm swing III) Front uprise to straddle sit IV) Straddle travel V) Rear or Stütz dismount	I) L-sit II) Any uprise from upper arm to front support III) Shoulder stand (2 sec.) IV) Long hang swing element V) Dismount • A or B dismount = +0.5; • Any non-listed but recognized dismount = +0.3	I) L-sit II) Front or back uprise from upper arm to front support III) Long hang swing element IV) Support swing element V) Dismount • A, B, or C dismount = +0.5; • Any non-listed but recognized dismount = +0.3	2 FIG Element Groups (FIG A(+0.5 ea.) Supplemental A(+0.3 ea.) 2 Second Handstand(+0.5) A Dismount (+0.5) Supplemental A Dismount(+0.3)	2 FIG Element Groups (+0.5 ea.) Press to 2 Second Handstand(+0.5) A Dismount (+0.3) B Dismount (+0.5)
Additional Regulations	• Any one skill may be performed twice for value. • NO Saltos (1.0 deduction) • Swings will count as an "A" part	• Any one skill may be performed twice for value. • NO Saltos (1.0 deduction) • 2 extra swings allowed	• 2 extra ½ swings allowed	• May compete with lower bars • Up to 20cm of extra mats allowed • Giant+Giant = C, C + 0.2 bonus • 1 permitted empty swing • +0.5 bonus for each additional Element Group requirement • Up to +0.2 virtuosity bonus	• Up to 20 cm of extra mats allowed • Giant+Giant = C, C + 0.2 bonus • 1 permitted empty swing • +0.5 bonus for each additional Element Group requirement • Up to +0.2 virtuosity bonus
"A" Skills		"B" Skills		"C" Skills	
<ul style="list-style-type: none"> L-sit Shoulder stand Straddle travel Forward shoulder roll Kip to straddle sit 		<ul style="list-style-type: none"> Back uprise Kip Back shoulder roll Drop kip Moy to upper arm From L-sit press shoulder stand Front toss to upper arm Any kip to immediate L-sit (2 B's) Back Stütz to upper arm Back shoulder roll to support Swing to shoulder stand 		<ul style="list-style-type: none"> Front uprise Reverse Straddle cut Forwards Straddle cut V-sit Sit to upper arm Cast up to upper arm Stütz to support Moy to support Press handstand Cast up to support Giant swing to support Peach to support Long hang back uprise to support Front uprise to immediate swing handstand (2 C's) Kip to immediate swing handstand (2 C's) Moy to upper from handstand Kip straddle cut to handstand Back uprise straddle cut 	
Dismounts		Dismounts		Dismounts	
<ul style="list-style-type: none"> Stütz dismount (front swing with ½ turn) Rear dismount 		<ul style="list-style-type: none"> Flyaway Tuck or Pike Rear dismount above 45° 		<ul style="list-style-type: none"> Any salto off side Layout flyaway Wende Stütz (hips horizontal) 	

• Horizontal Bars

Level 1 (Low Bar) Height 5'6", vaulting board may be used for the mount.

	Level 1	Level 2	Level 3	Level 4	Level 5
Start Value	Max. 6 counting skills (A=0.1) Special Req. +0.5 ea. Execution 10.0 Maximum D-Score 3.1 Plus Stuck Landing Bonus	Max. 6 counting skills (A=0.1, B=0.2) Special Req. +0.5 ea. Execution 10.0 Maximum D-Score 3.4 Plus Stuck Landing Bonus	Max. 7 counting skills (A=0.1, B=0.2, C=0.3) Special Req. +0.5 ea. Execution 10.0 Maximum D-Score 3.7 Plus Stuck Landing Bonus	Max. 6 counting skills with values as per FIG CoP Canadian Provincial Pathways Level 3 Rules Maximum D-Score 3.7 Plus Landing & Virtuosity Bonus	Max. 7 counting skills with values as per FIG CoP Canadian Provincial Pathways Level 4 Rules Maximum D-Score 4.0 Plus Landing & Virtuosity Bonus
Special Requirements	I) Pullover II) Front or back hip circle III) Leg cut forwards or backwards IV) Cast with feet at bar height V) Dismount • A dismount = +0.5; • Any non-listed but recognized dismount = +0.3	I) Any pullover II) Front or back hip circle III) Long swing element IV) Cast to horizontal V) Dismount • A or B dismount = +0.5; • Any non-listed but recognized dismount = +0.3	I) Kip or back uprise II) Front or back hip circle III) Underswing IV) Any element with ½ turn ▶ Excluding dismounts V) Dismount • A, B, or C dismount = +0.5; • Any non-listed but recognized dismount = +0.3	2 FIG Element Groups FIG A(+0.5 ea.) Supplemental A(+0.3 ea.) Giant(+0.5) A Dismount (+0.5) Supplemental A Dismount(+0.3)	2 FIG Element Groups (+0.5 ea.) Giant(+0.5) A Dismount (+0.3) B Dismount (+0.5)
Additional Regulations	• Any one skill may be performed twice for value. • NO Saltos (1.0 deduction) • 2 extra swings allowed • Single-leg cut in support, cast to bar height, and ½ turn in support may be used as "A" parts	• Any one skill may be performed twice for value. • NO Saltos (1.0 deduction) • 2 extra swings allowed • Spotters must be present	• 2 extra ½ swings allowed • Spotters must be present	• 1 layaway or empty swing allowed • Up to 20cm of extra mats allowed • Flight elements of "B" value or higher = +0.2 bonus • +0.5 bonus for each additional Element Group requirement • Up to +0.2 virtuosity bonus	• 1 layaway or empty swing allowed • Up to 20 cm of extra mats allowed • Flight elements of "B" value or higher = +0.2 bonus • +0.5 bonus for each additional Element Group requirement • Up to +0.2 virtuosity bonus
	"A" Skills	"B" Skills	"C" Skills		
	<ul style="list-style-type: none"> Pullover Back hip circle Stride circle Long swing pullover Swing ½ turn to 45° below horizontal Single-leg kip Front hip circle Underswing Cast to horizontal 	<ul style="list-style-type: none"> Any kip Straddle cut Straddled sole circle Jam cast to immediate backuprise (2 B's) Piked or straddled underswing ½ turn to long hang Long hang swing pullover from cast ("Baby Giant") Swing hop ½ turn to 45° below horizontal Back uprise Free hip circle Sole circle 	<ul style="list-style-type: none"> Back giant Cast handstand Pirouette Free hip to handstand Kip to immediate cast 45° above horizontal (2 C's) Back uprise to immediate free hip to handstand (2 C's) Back uprise to handstand Sole circle to handstand Swing ½ turn above horizontal Front giant Blind change Swing hop full turn 		
	Dismounts	Dismounts	Dismounts		
	<ul style="list-style-type: none"> Cast to straddle/pike underswing dismount Underswing dismount 	<ul style="list-style-type: none"> Cast straddle over dismount Piked or straddled underswing ½ turn dismount 	<ul style="list-style-type: none"> Front tuck ½ turn Front or back flyaway Double back tuck Pike off with front salto 		

1095.2

BERTHING

Berthing for the BCSS Gymnastics Provincial Championship can be awarded one of 4 ways; Direct Berth, Team Berth, Host Berth, or Wildcard Berth. All 4 of these criteria are determined by BC School Sports to fill all berths to the BCSS Gymnastics Championship

1095.2.1 Direct Berth: The top 70% of all athletes competing in each level (rounding down) at the Zone Championship will earn a direct berth to the BCSS Gymnastics Provincial Championships, with exception for levels with 4 or fewer gymnasts as summarized below;

# of Gymnasts in a Level at Zones	1	2	3	4
# of Direct Berths	1	2	2	3

1095.2.2 Team A Berth: Top 3 gymnasts competing for the winning Boys, Girls, and Combined Team in each zone. There berths are not in addition to athletes earning a direct berth. These are used to bring the school teams' complement of qualifying gymnasts to at least 3.

1095.2.3 Host Berth: Top 3 gymnasts per level for the BCSS Gymnastics Provincial Championship host school.

1095.2.4 Wildcard Berth: All remaining competition spots. Maximum of 50 gymnasts per level, will be allocated by BCSS with collaboration with the SAC Chair and Championship Host Committee Chair. Wildcard Berths will be allocated based on the following criteria;

- Based on the all-around score at the Zone Championships
- To provide a balance of representation from the 9 BCSS zones
- To proportion to the number of gymnasts competing at the Zone Championship
- In consideration of a petition to compete

If a zone is unable to fill their berths, the berth will be awarded by Wild Card process. The Wild Card berthing structure will be used to fill any additional spaces to allow for a full complement at provincial.

1095.3 STRUCTURE

The Championship meet will consist of 1 event per level (girls- 30 events, boys – 30 where all eligible athletes compete and are scored by judges. Athletes must compete in all of the events in their category to be able to contribute to their overall team score.

1095.4 SCORING

1095.4.1 Gymnasts will receive scores for routines as outlined below

1095.4.2 Scores will be converted to TEAM POINTS based on a percentage formula also outlined below. The purpose of this formula is to allow boys’ and girls’ scores to contribute equally to the team total, while also ensuring that each athlete is performing at a minimum standard. Performance above a 70% standard earns points, resulting in a maximum of 30 points that can be earned in each level. Points will be calculated per event so that a poor performance on one event does not prevent a single gymnast in a level from being able to contribute points to the team for good event performances. Half of the team points will come from the best all-around score, while 1/8 of women’s or 1/12 of men’s for each event score will count toward the team points total.

Example: Considering the following set of best scores for a Girls team (all levels have the same maximum of 10/event):

Event	Athlete score	Score as a %	Performance above 70% level <i>Score%</i> – 70%	Contribution to TEAM POINTS*	TEAM POINT TOTAL
Vault	8.4	$\frac{8.4}{10} \times 100\% = 84\%$	14	$\frac{1}{8} \times 14 = 1.750$	17.313
U.Bars	8.8	$\frac{8.8}{10} \times 100\% = 88\%$	18	$\frac{1}{8} \times 18 = 2.250$	
Beam	9.25	$\frac{9.25}{10} \times 100\% = 92.5\%$	22.5	$\frac{1}{8} \times 22.5 = 2.813$	
Floor	9.1	$\frac{9.1}{10} \times 100\% = 91\%$	21	$\frac{1}{8} \times 21 = 2.625$	
A.Around	34.3	$\frac{34.3}{40} \times 100\% = 85.75\%$	15.75	$\frac{4}{8} \times 15.75 = 7.875$	
<i>*Contributions to TEAM POINTS are rounded to three decimal places</i>					

The Team Points earned for this level would be 17.313 points

Considering the following set of best scores for a Boys Level I team (each level has its own maximum, Boys Level I Max=13.1/event):

Event	Athlete score	Score as a %	Performance above 70% level <i>Score%</i> – 70%	Contribution to TEAM POINTS*	TEAM POINT TOTAL
Floor	11.80	$\frac{11.8}{13.1} \times 100\% = 90.076\%$	20.076	$\frac{1}{12} \times 20.076 = 1.673$	20.648
P.Horse	11.80	$\frac{11.8}{13.1} \times 100\% = 90.076\%$	20.076	$\frac{1}{12} \times 20.076 = 1.673$	
Rings	12.40	$\frac{12.4}{13.1} \times 100\% = 94.656\%$	24.656	$\frac{1}{12} \times 24.656 = 2.055$	
Vault	12.80	$\frac{12.8}{13.1} \times 100\% = 97.710\%$	27.710	$\frac{1}{12} \times 27.710 = 2.309$	
P.Bars	11.20	$\frac{11.2}{13.1} \times 100\% = 85.496\%$	15.496	$\frac{1}{12} \times 15.496 = 1.291$	
H.Bar	11.50	$\frac{11.5}{13.1} \times 100\% = 87.786\%$	17.786	$\frac{1}{12} \times 17.786 = 1.482$	
A.Around	71.00	$\frac{71.0}{78.6} \times 100\% = 90.331\%$	20.331	$\frac{6}{12} \times 20.331 = 10.165$	
<i>*Contributions to TEAM POINTS are rounded to three decimal places</i>					

The Team Points earned for this level would be 20.648 points.

1096.0

AWARDS

- Ribbons for top 10 in each event and each member of the winning school team
- Medals for the top 3 all-around scores and rosettes for the 4th – 10th place all around scores
- Top team trophy
- Top team level trophies (1 per level per gender)
- Trophy and Rosettes for 1st, 2nd, and rosette in 3rd place all-around team in the boys and girls, and combined categories.
- Combined School Trophy and BCSS championship Banner for 1st place all-around team

1097.0 CHAMPIONSHIP HOSTING REQUIREMENTS

BCSS recognizes that most member schools do not have the facilities/equipment to host a Gymnastics Championship, and therefore need to book 3rd party facilities to host the championships. The facility chosen as the host location for the championship must have adequate gym space to be able to safely host all athletes, spectators, coaches, and gymnastics equipment.

If your school plans on submitting a bid to host a BCSS Gymnastics Championship and wants clarification on if your chosen facility has all of the requirements, please reach out to the BCSS office before submitting your bid.

1100.0 MOUNTAIN BIKING

** These rules are included as a placeholder in the 2021-2022 handbook, over the summer rules will be finalized by the BCSS office and brought to a vote by the Legislative Assembly at the Fall Planning Meeting in October.**

1101.0

Year	Max # of playing days	First Day of Play	Last Day of Play	Minimum Numbers	Season of Play
2021/22	26	Mon- Week 31	Sat- Week 43	1	Spring
2022/23	26	Mon- Week	Sat- Week	1	Spring
2023/24	26	Mon- Week	Sat- Week	1	Spring

1102.0 RULES

The rules governing BCSS Mountain Biking shall be that of the rules listed in this document with no rule modifications.

1103.0 EQUIPMENT

- 1103.1 All team participants are required to wear school colours and be properly attired. School names should be visible in order to help coaches, spectators and others to differentiate between riders.
- 1103.2 Each participant must be clearly identified with a race number plate, with his/her assigned number, affixed to the handlebars of his or her bike. Race number plates will be provided to coaches and racers prior to their event.
- 1103.3 Each participant is required to wear a helmet. Coaches should ensure that all helmets are in good condition. Helmets must be properly affixed to the rider by a tightened chin strap. Participants may not race with an improperly adjusted or damaged helmet.

1104.0 OFFICIALS

All official positions and times will be presented to the racer once their bike crosses the finish line by the Timing & Scoring Official. Officials for the BCSS Mountain Biking Provincial Championship will be chosen by the Championship Host Committee based on their experience in the sport.

1105.0 COMPETITION

1105.1

EVENTS

The Championship event provides two formats of competition, all competitors must start in both events in order to earn team points. The following events are the official championship disciplines:

- **All-Mountain (XC)** is an endurance event on a challenging course including double-track and single-track trails, climbing, descending, traversing and passing opportunities. Race Duration: race organizers seek to develop a race course that challenges riders abilities in the discipline. In order to maintain consistency from year to year, courses are developed with the following intended average completion times:

- Senior: 65-75 minutes
- Junior: 60 minutes
- Bantam: 50 minutes

- **Enduro** is a timed event in which the racer's finishing position is based on timed downhill stages, typically two to three different stages, combined between untimed transfer sections. The overall time of the racer is not considered, instead only the timed enduro stages are used for determining finishing order. The length of each stage, the number of stages, and the start format may differ at each Championship event. This is determined by the constraints of each individual course and in the spirit of having as clear and as unimpeded a flow as possible between racers. It is best practice for course officials to separate riders by 30 second intervals when enduro stage starting areas become busy and allowing riders to proceed at their own will could impede individual results.

1105.2

STRUCTURE

The Championship event will consist of timed heats in the All-Mountain event, and timed stages with staggered starts for each participant in the Enduro event. Finishers will be awarded points based on the following criteria:

Place	Points
1 st	100
2 nd	75

3 rd	50
4 th	40
5 th	30
6 th	25
7 th	20
8 th	15
9 th	10
10 th	5
11 th -15 th	2
16 th -20 th	1

1105.3 PROTESTS AND DISCREPANCIES

1106.3.1 Protests

All protests must be reported by the coach to the Race Director, in writing, within 30 minutes of the race heat finish. Protests will be investigated by the Race Director as thoroughly as possible and may result in disqualifications or time adjustments.

A school may appeal the protest in writing within 30 minutes of the ruling, appeals will be heard by the Discipline Committee. The Discipline Committee will decide to uphold or retract the ruling put in place by the Race Director.

1106.3.2 Discrepancies in Results

Discrepancies in placing and scoring are to be reported to the Race Director immediately. The Race Director will consult with the Timing and Scoring Official before making any changes to the results.

1105.4 TIE BREAKING PROCEDURE

In the event of a tie, the following procedure will be used to determine place:

- **Team** - overall points will be broken by calculating the lowest overall combined time for all of the included (maximum 20 in each division) individuals using the results from each division of the All- Mountain discipline
*Note: this must be calculated based on an equal number of competitors on each of the teams in each of the divisions, as it is possible for a team with fewer riders to accumulate an equal number of points. For example, if one team has 10 points earning riders and the other has 9, then the lowest overall combined time must include only the top 9 riders on the 10 rider team.
- **Individual** - If it is determined that two or more racers finish a race in a given discipline with the same time (even after considering fractions of a second) and in a medal position (1st - 3rd), then all of the tied riders will receive the appropriate medal for their placing at a later time. Example - three silver medals could be awarded if three racers finished with the same second place time.
- **King & Queen of the Mountain** - To break a tie in this category, the lowest cumulative time for the tied riders in both the All-Mountain and Enduro disciplines will be used to determine the winner.

1106.0 AWARDS

The following awards will be presented at the conclusion of the Championship event:

- **Team Overall** - The BCSS Provincial Championship award will be presented to the school team whose athletes earn the highest total number of points in both the All-Mountain and Enduro disciplines. The overall team winning school will be presented with the BCSS Provincial Championship banner and the BCSS Mountain Biking Commission Championship Cup.
- **Individual** - Gold, silver and bronze medals will be awarded to athletes who finish in 1st through 3rd positions in all categories (both boys and girls), and in both All-Mountain and Enduro disciplines
- **King and Queen of the Mountain** - Individual gold medals will be awarded to the King and to the Queen of the Mountain in all divisions based on the highest total points accumulated by an individual in both the All-Mountain and Enduro disciplines in their respective age division.

1110.0 RUGBY (15's)

** These rules are included as a placeholder in the 2021-2022 handbook, over the summer rules will be finalized by the BCSS office and brought to a vote by the Legislative Assembly at the Fall Planning Meeting in October.**

Year	Max number of play days	First Day of Play	Minimum Practices	Last Day of Play	Minimum Numbers	Maximum Roster	Season of Play
1111.0 2021/22	26	Mon; Week 31		Sat; Week 43	18	25	Spring
2022/23	26				18	25	Spring
2023/24	26				18	25	Spring

1112.0 RULES

The rules governing BCSS Rugby shall follow those of World Rugby with the following modifications;

- 1112.1 Game Duration
All BCSS rugby games shall be sixty (60) minutes in duration, having two (2) thirty (30) minute halves and a five (5) minute halftime.
- 1112.2 Substitutions
- For regular season games, tournaments and provincials, teams may use up to 10 players as substitutes
 - Among the substitutes 3 players must be suited to play front row positions, and at least one player for lock.
 - Players who are replaced may not return to play in the match
 - Players who are substituted may not return to play in the match with the exception that they are replacing an injured player
- 1112.3 Sin-Bin
The time in the "sin=bin" is 8 minutes not including half-time, or stoppages for injury.
- 1112.4 Ball Placement after Tackle
The use of the "turtle" or "squeeze ball" by a tackled ball carrier is not permitted, ball carriers must not lay face down and push the ball back between their body or legs when placing the ball.
- 1112.5 SEASON OF PLAY EXEMPTIONS
Schools in the North Central District SSAA, the Northwest Zone SSAA and the two (2) Kootenay SSAA may play senior boys rugby during the fall season of play, as long as the combined number of weeks in the Fall and the Spring leading up to and including the BCSS provincial championship week does not exceed thirteen (13) weeks of play.

1113.0 EQUIPMENT

- 1113.1 Wearing a mouth guard is mandatory. No player will be permitted to participate in a game without one
- 1113.2 Cleats must not have metal studs

1114.0 OFFICIALS

BCSS Championships will be officiated by certified BC Rugby Officials.

1115.0 COMPETITIONS**1115.1 EVENTS**

- 1115.1.1 The following events will be contested in the BCSS rugby provincial championships:
- AA
 - AAA
 - AAAA

1115.2 BERTHING

1115.3 STRUCTURE

The AA and AAA Championships will each consist of 16 teams split into two tiers of eight (8) teams. Tier one will contest the provincial championship. Tier 2 will contest the Tier 2 championship. Consolation matches will be played in both tiers within the AA and AAA championship

The AAAA Championship will consist of the top 4 teams in the province. They will compete in a round robin style tournament until a AAAA champion is determined

1115.4 SEEDING

Tournament seeding (including which teams are in which tiers) is determined by the seeding committee as appointed by BC School Sports and will be determined based on regular season, exhibition and zone play.

1115.5 TIE BREAK PROCEDURE

Should teams be tied at the end of regulation time, the winner shall be determined according to the following order

- Two periods of five (5) minutes extra time, the first team to score during this time will be deemed the winner; if at the end of extra time, no team has scored, then the winner will be determined using the following metrics, in succession, until a team is determined to be the winner.:
 - Team with the most tries scored
 - Team with the most conversions scored
 - Team with the most drop goals scored
 - Team with the most penalty goals scored
 - First points scored in the game

1116.0

AWARDS

- BCSS Championship Banner will be awarded to the top team in the AA, AAA, and AAAA categories.
- 25 Gold, 25 Silver and 25 Bronze Medals will be awarded to the top 3 teams in each tier (AA Tier 1, AA Tier 2, AAA Tier 1, AAA Tier 2, and AAAA)

1117.0 CHAMPIONSHIP HOSTING REQUIREMENTS

BCSS recognizes that most member schools do not have the facilities to host a BCSS Rugby championship, and therefore need to book 3rd party facilities to host the championships. The facility chosen as the host location for the championship must abide by the up-to-date World Rugby minimum field requirements.

If your school plans on submitting a bid to host a BCSS Rugby Championship and wants clarification on if your chosen facility has all of the requirements, please reach out to the BCSS office for further clarification.

1120.0 SKI & SNOWBOARD

** These rules are included as a placeholder in the 2021-2022 handbook, over the summer rules will be finalized by the BCSS office and brought to a vote by the Legislative Assembly at the Fall Planning Meeting in October.**

Year	Max number of playing days	First Day of Play	Last Day of Play	Minimum Numbers	Maximum Roster	Season of Play
2021/22	15	Week 18-Mon	Week 29-Sat	4	6	Winter
2022/23	15	Week-	Week-	4	6	Winter
2023/24	15	Week-	Week-	4	6	Winter

1122.0 RULES

The rules governing BCSS Ski and Snowboard shall be that of the Canadian Ski and Snowboard Association with no modifications.

1124.0 OFFICIALS

All officiating and timing will be done through the Ski Hill contracted for the event.

1125.0 COMPETITIONS

1125.1 EVENTS

1125.1.1 The following events will be contested at the BCSS Ski & Snowboard provincial championships in both the Boys and Girls category:

- Snowboard: 2 run Giant Slalom (GS) , 1 run Terrain Giant Slalom (TGS)
- Skiing: 2 run Giant Slalom, 1 run Terrain Giant Slalom

1125.2 BERTHING

Berths will be allocated

The top 3 finishers in each event in each zone in each category will qualify for provincial championships (216 individual berths).

1125.3 STRUCTURE

The BCSS Ski and Snowboard Provincial Championships will consist of 3 snowboard runs (2 GS, 1 TGS) and 3 skiing runs (2GS, 1 TGS) in both a boys and girls category. Once all runs are complete the top girls, boys, and combined teams with the highest overalls score.

1125.4 SEEDING

Seeding for the championship will be determined by the appointed seeding committee with collaboration with the BCSS office based on zone results converted into points. Points per seed are calculated based on the number of teams that enter into the race. First place = 12 points, second place = 11 points, etc. This structure will be used for both skiing and snowboarding.

1126.0 AWARDS

A BCSS Blue Championship Banner will be awarded to the top boys, girls, and combined teams in both Ski and Snowboard (6 banners)

1127.0 CHAMPIONSHIP HOSTING REQUIREMENTS

BCSS recognizes that member schools must host this championship at a 3rd party, before submitting a bid it is recommended that an interested host school contacts BCSS to determine if their venue is suitable for the championship.

1130.0 SOCCER

1130.1**Boys**

	Maximum Contest Days	First Day of Play	Last Day of Play	Minimum Numbers	Season of Play
2021/22	26	Week 6	Week 17	11	Fall
2022/23	26	Week	Week	11	Fall
2023/24	26	Week	Week	11	Fall

Girls

Year	Maximum Contest Days	First Day of Play	Last Day of Play	Minimum Numbers	Season of Play
2021/22	26	Week 31	Week 44	11	Spring
2022-23	26	Week	Week	11	Spring
2023/24	26	Week	Week	11	Spring

1132.0 RULES OF PLAY

The rules of play for BC School Sports Soccer shall be the Laws of the Game as published by BC Soccer, with the following modifications:

- 1132.1 All Zone and Provincial matches will consist of two (2) 35-minute halves.
- 1132.2 Teams are permitted unlimited substitutions.
- 1132.3 Teams may have an unlimited number of players on their team roster but are permitted to dress only 20 players per match. The 20 players in uniform may change from match-to-match. Players or other team personnel who are not included in the 20 must be easily identified (i.e. street clothing) and are not permitted to wear a team uniform or pinnies while on the bench.
- 1132.3.1 Coaches are responsible for the behaviour of all students and personnel on the bench
- 1132.3.2 Teams must submit the roster for each match on the sheet provided by the Championship Host committee, no less than 30 minutes before the start of each game.

1134.0 EQUIPMENT

- 1054.1 The official game ball of BCSS Soccer will be an Adidas Authentic Championship Game Ball
- 1054.2 Uniform Requirements:
- All players must be dressed in matching uniforms.
 - Players' jerseys must be numbered 1 – 99 with the exception of the goalie.

1135.0 OFFICIALS

Officials at BC School Sports Zone and Provincial Championships will be certified and registered with BC Soccer.

Officials are prohibited the use VAR, replay or video in evaluating, upholding or reversing an on-field decision. Replay and video can be used when reviewing (an) event(s) for the purposes of discipline.

1136.0 PROVINCIAL CHAMPIONSHIPS

1136.1 BERTHING

Berthing for BCSS Provincial Championships will be determined by the following criteria:

1136.1.1 Each BCSS zone with an eligible senior team will receive a minimum of one (1) berth to the championship

1136.1.2 Remaining berths will be allocated based on the percentage of active senior programs in each BCSS zone. If a zone does not fill their berth it will be allocated using the percentage method to the next zone.

$$\frac{\text{Total Number Schools with Registered Teams}}{\text{Total Number of Eligible Berths}} = \text{Berthing ratio}$$

* If a zone does not have any teams participating that berth will go back into the total number of eligible berths.

$$\frac{\text{Total Number Schools with Registered Teams}}{\text{Teams/Zone Berthing Ratio}} = \text{Number of Berths/zone}$$

1136.1.3 A host berth can be allocated, where championships are hosted by a school. In centralized championships, no host berth shall be granted.

1136.1.4 If two or more zones have equal berth allocation calculations competing for remaining berths, then the remaining berths will be awarded to the zone which finished higher in the previous year's Championships.

1136.2 TOURNAMENT STRUCTURE

1136.2.1 The BCSS Provincial Soccer Championships will consist of a 16-team tournament in each of the following tiers, '

1136.2.1.1 Girls: A; Girls AA; Girls AAA.

1136.2.1.2 Boys A; Boys AA; Boys AAA.

1136.2.2 Each championship will involve no more than three (3) days of competition.

1136.2.3 The Championship structure will contest a round robin with four pools with four teams each. With each team playing each of the teams within their pool.

1136.2.3.1 ROUND ROBIN POOLS

Pool A	Pool B	Pool C	Pool D
1	5	9	13
2	6	10	14
3	7	11	15
4	8	12	16

1136.2.4 Teams will be seeded into a Bracket at the conclusion of the round robin, with the first-place teams moving to the semi-finals, the 2nd place teams contesting the 5th-8th spots, 3rd place in each pool playing a bracket for 9th-12th and the fourth place teams in each pool, moving to a bracket to contest the 13th to 16th place spots.

1136.2.4.1 CHAMPIONSHIP DRAW

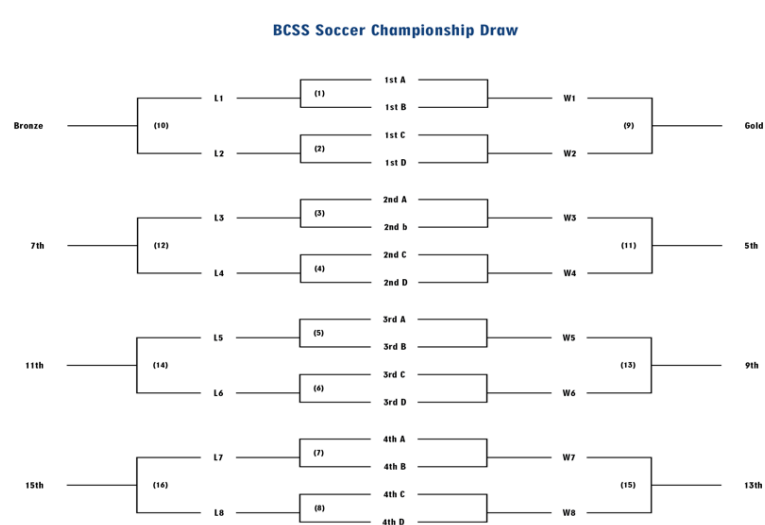

1136.2.5 The Championship Draw will be completed in the week following the Team Registration Deadline by a committee. The pool placements will be established prior to any zone competition and therefore will be assigned to zone placements, not specific teams, and will be based on the following priorities:

- The top two teams from any one zone shall not be in the same pool or on the same side of the championship draw
- Where possible, the committee will avoid putting teams from the same zone in the same pool
- The committee may look at the historical strength of zones when evaluating the seeding
- The committee may explore the relative strength and weaknesses of zones that year for further guidance

BOOKINGS, PLAYER CONDUCT AND DISCIPLINE

1132.4 Any player receiving 3 yellow cards during either the zone or provincial tournaments (as single events, not combined) must sit out the following game. Additional games may be given at the discretion of the Championship Discipline Committee.

1132.5 Any player receiving a red card is automatically suspended from further participation in the tournament subject to a hearing of the Championship Discipline Committee.

1132.5 Any incidents of player misconduct will be evaluated and ruled on by the Championship Discipline Committee

1136.2.5 Tie-Game Procedures

1136.2.5.1 In round robin games, should the score be tied at the conclusion of regulation (and stoppage) time. Each team receives one point and the game is over.

1136.2.5.2 If any game in the Championship draw (after round robin) is tied at the end of regulation time (and stoppage time) an overtime of two 7.5 minute halves (7:30) will be played. NO Golden Goal will be used. If at the conclusion of the overtime the game is still tied then penalty shots will be taken (F.I.F.A. rules).

1136.2.5.3 On the final day of the Championship, placement games (games to place schools 5th to -16th) not have overtime and will go straight to penalty kicks.

1136.2.6 Tie-Breaking Procedure (Pools)

1136.2.6.1 Two Teams Tied

The winner of the pool play match between the two teams tied in points shall be awarded the higher position.

If the two tied teams, also tied their pool play match, then the team with the best goal differential across all pool matches will be awarded the higher position.

If the teams remain tied, the team with the fewest goals allowed across all pool matches will be awarded the higher position

If the teams remain tied, the tied teams will contest a mini-game of 5 alternating penalty kicks for each team to determine the winner. If tied after 5 shots each, each team will alternate single penalty kicks in a sudden-victory format when there is a winner after each teams have had an equal number of attempts.

1136.2.5.4 Three or More Teams Tied

This process will be used sequentially, and in its entirety, if needed, to place the teams following round robin play. If a step breaks the tie for some but not all teams, the remaining tied teams will be evaluated on the following step. Throughout these steps, Only the games between the tied teams will be used throughout the tie-breaking procedure

1136.2.5.4.1 Goal Differential

Goal difference is calculated by subtracting Goals conceded from Goals scored. A maximum of plus-five (+5) goals shall be awarded for any single match. (Example: a 5 – 0 score (+5 goal difference), a 7 – 1 score (+5 goal difference), a 7 – 3 score (+4 goal difference).

1136.2.5.4.2 If teams remain tied, the team having the fewer number of goals against will be awarded the higher position.

1136.2.5.4.3 If teams remain tied, then the higher standings shall be decided by kicks from the penalty spot, as follows:

- Three teams tied: Each team is designated A or , B, or C. Three mini-games shall be played (A vs B, B vs C, C vs A) consisting of five (5) penalty kicks at a time and place to be decided by the Commission Representative.
- Four teams tied: Each team is designated A, B, C, or D. Six mini-games shall be played (A vs B, C vs D, A vs C, B vs D, D vs A, and C vs B), to decide the final ranking as in the three team case.
- The standings after these three/four mini-games shall be ranked. All five shots are to be taken in each mini-game regardless of the score. The total goals scored in the mini-game will be used to decide placement.

1136.2.7 Protests

Protests will be received by the Tournament Director and evaluated by the Championship Discipline Committee

1136.2.7.1 A team wishing to protest must do so within 30 minutes of the completion of the game along with a \$250.00 protest fee. In the event that a protest is upheld by the Discipline & Protest Committee, the protest fee shall be refunded. In the event that the protest is denied, the protest fee shall be retained. The grounds for the protest must be submitted in writing from the Head Coach of the team and must be signed off on by the athletic director or an administrator at the school.

1136.2.7.2 The protest must contain the details of the protest, including the rule that was allegedly breached, and the evidence to support that claim. Protests can only be considered on the grounds of misinterpretation of FIFA Laws of the Game, on the eligibility of players, or on breaches of BCSS Policy as listed in the BCSS Handbook. A team may not protest a judgement or discretionary call of an official.

1136.2.7.3 Any team playing an ineligible player shall forfeit the game to its opponents, provided the protest is upheld.

- 1136.2.7.4 A copy of the protest shall be provided to the opposing team as soon as possible after the receipt of the protest. The opposing team shall be provided an opportunity to respond within the time provided by the tournament director, not exceeding one hour. Failure to provide a response in this time may result in the Discipline Committee rendering its decision based solely on the information provided by the protesting team. The Discipline Committee may also review the protest with the game officials or others they feel may provide relevant information to the deliberations.
- 1136.2.7.5 Once a decision is rendered, the Tournament Director will provide a verbal ruling to the teams involved. Additionally, the Tournament Director shall provide to all parties, a written ruling which shall include the rationale for the decision and the associations appeal procedures, within five (5) working days the decision.
- 1136.2.7.6 Appeals to decisions made by the Discipline Committee are made to the BCSS Executive Director or their designate. There is a \$500 fee to appeal a decision made by the Discipline Committee which must be submitted in writing, be submitted by the Head Coach, and signed off on by the Athletic Director or an Administrator at the school. \$100 of the fee is non-refundable, \$400 shall be refunded upon an overturning of the ruling. The Appeal must state concisely the grounds for the appeal and be received within 3 hours of the decision from the Discipline Committee being received.

1136.4

AWARDS

BCSS will present the following awards each BCSS Provincial Soccer Championship

- 21 Gold, 21 Silver, 21 Bronze BCSS Championship Medals
- BCSS Provincial Champions Banner
- Boys AA/AAA Team Sales Clyde Hughes Award
- Commissioner's Eleven
- Tournament MVP
- 16 team keeper placing plaques with team photo
- Golden Boot – top goal scorer of tournament
- Fair Play – most sportsmanlike team

1137.0 CHAMPIONSHIP FACILITY HOSTING REQUIREMENTS

The host is required to have access to four (4) regulation size soccer fields. These fields do not need to be on a single site but must be in relative proximity to one another.

1140.0 TENNIS

1141.0

Year	Contest Dates	First Day of Play	Last Day of Play	Minimum Games before Championship	Minimum Numbers	Season of Play
2021/22	24	Week 31	Week 43	2	5	Spring
2022/23	24	Week	Week	2	5	Spring
2023/24	24	Week	Week	2	5	Spring

1142.0 RULES OF PLAY

The rules governing Tennis shall follow those of Tennis Canada with the following modifications;

- 1143.1 Calls of “out” and “let” should be made immediately. Any doubt must be resolved in favor of your opponent.
- 1143.2 A team is to consist of a minimum of 5 boys and 5 girls.
- 1143.3 A minimum five minute warm-up is allowed before each set
- 1143.4 Players will spin for service or side, and will change sides after the first and every odd game.
- 1143.5 A set is concluded when one player (or doubles team) has won 6 games.
- 1143.6 ‘No-Ad’ scoring will be used for Round-Robin matches, while ‘Ad-Scoring’ will be used for playoff matches. No-ad scoring means that when the players are tied at deuce in a game, the next point wins the game, but the receiver (receiving team) has the choice of which side they would like to receive the serve.
- 1143.6 A 12-point tie break will be played if a set reaches 5 - 5.
- 1143.7 Each match is made up of 11 sets. All matches will be played to completion (11 sets) unless otherwise determined by the tournament director;
- 1143.7.1 The matches will be played in the following order, the first team listed is designated as the home team;
- Girls Doubles A vs B
 - Girls Doubles B vs A
 - Boys Doubles A vs B
 - Boys Doubles B vs A
 - Girls Singles
 - Boys Singles
 - Girls Doubles A vs A
 - Girls Doubles B vs B
 - Boys Doubles A vs A
 - Boys Doubles B vs B
 - Mixed Doubles

- 1143.8 A player may only play in one division (“girls doubles,” “boys doubles,” & “singles / mixed”) and may play a maximum of two sets. Additionally, players may NOT play singles and doubles or on both an A and B doubles team.
- 1143.9 Coaches must list players for the first six sets and submit this roster to the site supervisor (or exchange with the opposing coach, if no site officials are present) prior to the start of the match. There is no penalty for substituting players into the second round of (the final five) sets.
- 1143.10 Sets within a match will proceed in the order as listed in 1143.7.
- 1143.11 Coaches are permitted to coach their team only during an end change, as long as it does not cause a delay in the match (maximum of 1 minute). When coaches wish to coach during an end change, they must call their players to the fence to talk with them.
- 1143.12 During a match, all coaches and players, and their belongings, not involved in the ongoing sets must remain outside the fence surrounding the courts. Only the players involved in the ongoing sets, and any belongings they require, are allowed inside the fence.
- 1143.13 Following a match it is the responsibility of each coach to sign the site supervisor’s scoresheet signifying the result is correct. In addition, the winning team is responsible for returning all used balls. Results do not become official until all balls are returned.
- 1143.14 In the event of a delay, a maximum of fifteen minutes is allowed before the offending team will be forced to forfeit the match. If team(s) encounter an unforeseen delay, they are expected to contact the tournament director
- 1143.15 In the event inclement weather, the tournament will be adapted to play at indoor courts where available. At the discretion of the Tournament Director, match format may be shortened. This format sees 7 sets played, instead of 11. (matches will include the first 6 games as listed on the scoresheet, and the mixed doubles). The Team winning 4 sets in the shortened format is the winner of the match. In addition, all players would have to be listed on the scoresheet before a shortened match begins. (Please refer to the “BCSS Tennis Inclement Weather Scoresheet.”)

At the discretion of the Tournament Director, other changes may be instituted to accommodate inclement weather. The most common are a change the start times and/or use ‘no-ad scoring’ on Friday and Saturday. Other changes may be necessary depending on the length of delays and access to indoor courts. These changes are at the discretion of the Tournament Director, in conjunction with BCSS Staff.

1144.0 EQUIPMENT

The BCSS Provincial Tennis Championships use the Penn Marathon Ball

1145.0 OFFICIALS

Each event site will include one (1) site organizer and one (1) site umpire.

1146.0 PROVINCIAL CHAMPIONSHIPS

- 1146.1 **BERTHING**
Both the AA and AAA Championships shall each consist of 12 teams. Each zone will be allocated a minimum of one (1) berth and the host school where applicable will receive an automatic berth. The following procedure will be used to determine the allocation of remaining at-large berths:

$$\frac{\text{Number of Registered Teams}}{\text{At-large Berths at Tournament}} = \text{Berthing Ratio}$$

$$\frac{\text{Number of Registered Teams}}{\text{Berthing Ratio}} = \# \text{ of berths/zone}$$

No zone will receive more than 4 berths (including the host berth).

- 1146.1.1 In the event that the exact number of berths is not allocated, the decimal component of the zone allocation value is considered to two (2) decimal places. (In the event that the

decimal components are equivalent (1.52, 2.52, 3.52) and not all can receive remaining berths, preference shall be given in this order:

- Zones not in the host rotation
- Zones least recently awarded “left-over” berths
- Zones closest to host location (thereby reducing travel costs)

1146.2 TOURNAMENT STRUCTURE

1146.2.1 The AA & AAA BCSS Tennis Provincial Championships shall each consist of 12 teams competing in a round robin pool play, moving to the final or consolation draw based on their round robin placement as indicated below.

1146.2.3 The seeding for both the AA and AAA Tennis Provincial Championships will be determined based on strength and final zone placement of the qualifying teams as well as historical success at provincials over the last three (3) years. Each coach is asked to rank their team and identify their provincially ranked players. A Seeding committee appointed by BCSS will take into consideration the coaches ranking and the team’s historical strength when seeding the championship.

1146.2.4 Round Robin Structure

A	B	C	D
1	2	3	4
7	5	8	6
12	11	10	9

1146.2.5 Championship Draw

BCSS Tennis Championship Draw

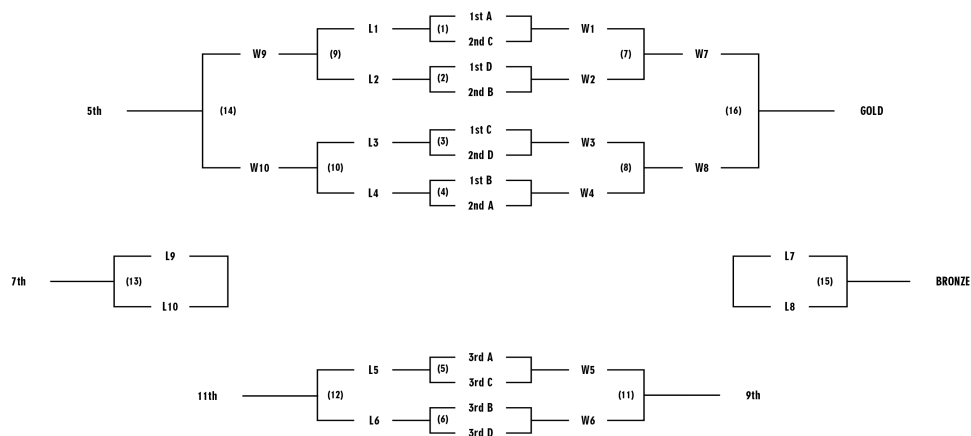

1146.3 TIE BREAK PROCEDURE

If at the conclusion of round-robin play, teams are tied, the following procedures will be used to determine the higher placed team.

1066.5.1 If two teams are tied, their head-to-head record will be used

1066.5.1 If more than two teams are tied then the determination will be made following these steps in sequential order. If any one step identifies the winning team, but the next two teams remain tied, the tie break procedure continues at the next sequential step:

- the highest set differential (sets won v. sets lost) during all round robin matches.

- The highest number of sets won during all round robin matches.
- The highest game differential (games won v. games lost) during all sets of all round robin matches
- The team with the highest number of games won during all round robin matches
- Flip of a coin

1147.0 AWARDS

- BCSS Blue Provincial Champion Banner
- 16 Gold, 16 Silver, 16 Bronze Medals provided to the top three teams in each tier
- Every team receive a placement plaque which include their team photo
- Trophies awarded in both tiers to the following:
 - Top singles, male and female
 - Top doubles team, male and female
 - Top mixed doubles teams

1148.0 CHAMPIONSHIP HOSTING REQUIREMENTS

BCSS recognizes that most member schools do not have the facilities to host a BCSS Tennis championship, and therefore need to book 3rd party facilities to host the championships. The facility chosen as the host location for the championship must abide by the up-to-date Tennis Canada minimum court requirements and be able to host at least 16 courts. Host schools may use multiple venues granted they are in close proximity to each other and provide similar playing environments.

1150.0 TRACK AND FIELD

** These rules are included as a placeholder in the 2021-2022 handbook, over the summer rules will be finalized by the BCSS office and brought to a vote by the Legislative Assembly at the Fall Planning Meeting in October. **

1151.0

Year	Number of Playing Days	First Day of Play	Last Day of Play	Minimum Numbers	Season of Play
2021/22	15	Week 31; Mon	Week 45; Sat	1	Spring
2022/23	15	Week	Week	1	Spring
2023/24	15	Week	Week	1	Spring

1152.0**RULES**

The rules governing BCSS Track and Field shall follow those of World Athletics (formerly IAAF) with the following modifications;

- 1152.1 Athletes may only compete in individual events at the same level
- A grade 8 cannot compete in the grade 8 shot put and the junior discus
 - A grade 10 cannot compete in the junior 100m and in the senior 400m
 - Grade 8 athletes are ineligible for junior race walk, discus & hammer throw events; unless they are competing in the junior category in all individual events.
- 1152.2 Relay Rules
- Athletes may compete in a different relay category from their individual events
 - A grade 10 athlete may compete in the junior 100m and the senior 4x100m
 - A grade 9 athlete may compete in the junior 400m and the senior 4x400m
 - A grade 10 athlete may compete in the junior 4x400m and the senior 4x400m
- 1152.3 Athletes with Conflicting Events: Track events take precedent over field events. Athletes must notify the officials at all field events that are in conflict. Athletes in the field events will forego their attempt in a round if the round has been completed before they return

Girls	Shot Put	Hammer Throw	Discus Throw	Javelin Throw
Senior	4 kg	4 kg	1kg	600 g
Junior	3 kg	3 kg	1 kg	500g
Grade 8	3 kg	3 kg	1 kg	500g
Boys	Shot Put	Hammer Throw	Discus Throw	Javelin Throw
Senior	6 kg	6 kg	1.75 kg	800 g
Junior	5 kg	5 kg	1.5 kg	700 g
Grade 8	4 kg	4 kg	1 kg	600 g

1153.0**EQUIPMENT**

- Athletes must have a competition bib number to compete
- Competition numbers must be worn on the front for all track events, and front or back for field events.
- Athletes must compete in their school uniform. Athletes not in a school uniform will not be allowed to compete
- Relay teams should be in identical uniforms.
- All implements will be supplied by the meet organizers. Athletes may use their own implements providing they meet World Athletics (formerly IAAF) standards. They must be weighed-in and measured at least 45 minutes prior to competition
- The maximum spike length allowed is 7mm for all events except high jump and javelin. Maximum spike length for high jump and javelin is 9mm
- The following equipment/distance specifications will be used for all Track and Field competitions;

Hurdle Specifications

	Boys	Girls
Grade 8	100m - 33" (0.84m)	80m – 30" (0.762m)
Junior	100m - 36" (0.914m)	80m – 30" (0.762m)
Senior	110m - 36" (0.914m)	100m – 33" (0.84m)
Grade 8	200m – 30" (0.762m)	200m – 30" (0.762m)
Junior	300m - 33" (0.84m)	300m - 30" (0.762m)
Senior	400m - 36" (0.914m)	400m – 30" (0.762m)

Steeplechase Specifications

	BOYS	Girls
Junior	1500m - 30" (0.762m) with water	1500m - 30" (0.762m) with water
Senior	2000m - 33" (0.84m) with water	1500m - 30" (0.762m) with water

1154.0

OFFICIALS & TIMING

The BCSS Track and Field Championships will be officiated by certified BC Athletics Officials and use laser timing for all track events.

Protests: Any protest may be filed in writing by the Head Coach of program, within 30 minutes of the posting of official results, to the Competition Secretary and accompanied by a \$50 cheque made out to BC School Sports. The protest will be reviewed by the Jury of Appeal. If the protest is upheld then the protest fee will be returned. The Jury of Appeal is comprised of three impartial experienced persons who will review evidence & make a decision. Their decision is final. See World Athletics Rule #146

1155.0

COMPETITIONS

1155.1 EVENTS

- 1155.1.1 The following events will be contested in the Grade 8 Invitational competition categories:
- **Heats/Finals:** 100m, 200m, 400m, 800m, 80m hurdle (Girls), 100m hurdle (Boys), 200m hurdle
 - **Timed Finals:** 1500m, 3000m, 4x100m, 4x400m
 - **Field Events:** Long jump, Triple Jump, High Jump, Shot Put, Javelin

- 1155.1.2 The following events will be contested in the junior invitational (grade 9/10):
- **Heats/Finals:** 100m, 200m, 400m, 800m, 1500m, 80m hurdle (Girls), 100m hurdle (Boys), 300m hurdle, 4x100m, 4x400m.
 - **Timed Finals:** 1500m Steeplechase, 3000m, 1500m Racewalk
 - **Field Events:** Javelin, Hammer, Discus, Long jump, Triple Jump, High Jump, Shot Put

- 1155.1.3 The following events will be contested in the Grade 8 Invitational competition categories:
- **Heats/Finals:** 100m, 200m, 400m, 800m, 1500m, 100m hurdle (Girls), 110m hurdle (Boys), 400m hurdle, 4x100m, 4x400m.
 - **Timed Finals:** 1500m/2000m Steeplechase, 3000m, 1500m Racewalk
 - **Field Events:** Javelin, Hammer, Discus, Long jump, Triple Jump, High Jump, Shot Put

1155.2 BERTHING

Zone representation berthing (number of entries) is based on the numbers-based-allocation formula determined by BC School Sports to fill 30 of the 32 berths to the BCSS Track and Field Provincial Championship and the Junior Invitational

The 2 remaining berths will be open for student-athletes that couldn't compete in their Zone Championship but would have otherwise qualified for the Provincial Championship. If those berths are not filled, they will become open berths to the two highest non-qualifying athletes.

- 1155.3 **STRUCTURE**
The Championship meet will consist of preliminary and final heats in each event. Individual and relay events will include a championship final (1-8) and a consolation final (9-16).
- 1155.4 **SEEDING**
Heats will be determined by the meet director and head official in collaboration with the BCSS office based on entry times from zone championships
- 1155.5 **SCORING**
Points are scored for individual & relay events based on the following:

1st	10 points
2nd	8 points
3rd	6 points
4th	5 points
5th	4 points
6th	3 points
7th	2 points
8th	1 points

Points accumulate for team scoring in the Junior & Senior categories. Points earned in a Junior Invitational event, do not contribute to the points used to calculate the BCSS Championship Banner. Only senior events will be used to calculate the winners of the BCSS Track and Field Championship.

1156.0 AWARDS

BCSS Championship Banners will be awarded to:

- Overall School Winner (combined both genders); A, AA, AAA
- Senior Boys Team Aggregate Winner; A, AA, AAA
- Senior Girls Team Aggregate Winner; A, AA, AAA

Individual Awards

- Medals for 1st-3rd in each event in each category (Boys/Girls)
- Ribbons for 4th-8th in each event in each category (Boys/Girls)
- Most Outstanding Senior Female Athlete of the Meet
- Most Inspirational Athlete of the Meet
- Most Outstanding Senior Male Athlete of the Meet

1161.0

Year	Max # of Play Dates	First Day of Play	Last Day of Play	Minimum Numbers	Season of Play
2021/22	26	Mon; Week 31	Sat; Week 43	9	Spring
2022/23	26			9	Spring
2023/24	26			9	Spring

1162.0

RULES OF PLAY

The rules governing BCSS Ultimate shall be those of the USAU 11th Edition Rules with the following modifications:

- 1162.1 **Point Target** - Games have a Point Target of 13. Once a team reaches the Point Target they have won and the game is over. There is no need to win a game by 2 points (i.e. a game that is 13-12 is over).
- 1162.2 **Championship Games** - All placement games (eg. 5th place, 16th place) are played under the same rules as other games in the tournament. There are two (2) Championships games (AA & AAA). Championship games have a Point Target of 15.
- 1162.3 **Half Time** - Games will have a "Mirror Half" after the first team reaches 7 in a normal game or 8 in a Championship game. There is no break at Half Time, but for the next pull teams will be the opposite (or mirror) of the pull that started the game. (i.e. If Red pulled to Blue from the North End zone at the Start of the game then Blue pulls to Red from the North End zone after Half Time).
- 1162.4 **Soft Cap** - Games will have a Soft Cap 75 minutes after the scheduled start time of the game. Soft Cap will be indicated by an Air Horn, but team Captains should be aware of the time and work with the opposing team to put the Soft Cap into place at the appropriate time. Official time will be that shown by a cell phone and not a wrist watch. After 75 Min, the current point is completed and a new Point Target is created by adding 1 to the highest current score. The first team to reach this new Point Target will win the game. Example - If the score is 10-8 when the Soft Cap happens, then the point that is in progress ends and if the score is 11-8, the new Point Target for the game is 12. A new point is considered to have started as soon as the previous point has concluded.
- 1162.5 **Hard Cap** - Games will have a Hard Cap 85 minutes after the scheduled start time of the game. Hard Cap will be indicated by an Air Horn, but team Captains should be aware of the time and work with the opposing team to put the Hard Cap into place at the appropriate time. Official time will be that shown by a cell phone and not a wrist watch. After 85 Min, the current point is completed and the team with the most points is the winner. If the game is tied after the current point, one more point will be played. A new point is considered to have started as soon as the previous point has concluded.
- 1162.6 **Caps for Championship Games** - Final games will have a Soft Cap 90 Minutes and a Hard Cap 100 minutes after the scheduled start time.
- 1162.7 **Time-outs** - Teams are given 1 time-out per half + 1 floater time-out per game. Teams can take a maximum of 2 time-outs per half, and a maximum of 3 time-outs per game. Time-outs should be limited to 90 seconds. No time-outs can be called during a Cap. Note that a Cap is not "on" until the conclusion of the current point. If the Cap is announced during a point, teams may still take a time-out during that point.
- 1162.8 **Zone Defence** - Teams may use zone defence.
- 1162.9 **Foot-blocks** - Foot-blocks are legal.

1162.10 **Gender Ratio Rule** - At the start of the game, after the first disc flip, an additional disc flip happens with the winner selecting the gender ratio for the first point. For the second and third points the ratio must be the reverse of the first point. For the fourth and fifth points the ratio must be the same as the first point. This pattern of alternating the ratio every two points repeats itself until the end of the game (half time has no impact on the pattern).

1162.11 Teams must have a minimum number of nine (9) players on their team. There is no maximum number of players. All players must be registered with BC School Sports and be on the appropriate roster in STARS. Teams must field seven (7) players on the field at one time and be in accordance with the applicable gender ratio.

1163.0 EQUIPMENT

All teams attending Championships must have jerseys/shirts of matching colour and design. Numbered jerseys are permitted but are not required. Numbered jerseys should have numbers on the back and no two players should have the same number. Matching shorts are recommended but not required.

1164.0 OFFICIALS

All BCSS Ultimate competitions will be self-officiated by players on the field. Players off the field are not permitted to make calls while on the sidelines. If any call is challenged the ruling will be in favour of the opponent.

1165.0 PROVINCIAL CHAMPIONSHIP

1165.1 **BERTHING**

Qualification for both the AA and AAA tournament will happen at the zone level. Teams who win their Zone Championship will automatically have a spot in Championships (9 teams). The remaining seven (7) spots will be determined using the following berthing formula:

$$\frac{\text{Total Number Schools with Registered Teams}}{\text{Total Number of Eligible Berths}} = \text{Berthing ratio}$$

* If a zone does not have any teams participating that berth will go back into the total number of eligible berths.

$$\frac{\text{Total Number Schools with Registered Teams}}{\text{Teams/Zone Berthing Ratio}} = \text{Number of Berths/zone}$$

1166.2 **STRUCTURE**

BCSS Ultimate AA and AAA Provincial Championships will consist of 16 teams competing in a two (2) day championship tournament. Day one (1) will be a round robin pool play structure, day two (2) will have playoffs of the championship and consolation brackets.

1166.3 **SEEDING**

Seeding for the round robin play will be determined by the Championship Host Committee after the provincials' team registration deadline. The committee will take into consideration standings during league play as well as historical strength to ensure fair seeding for the championship.

1166.3.1 **ROUND ROBIN POOLS**

Pool A	Pool B	Pool C	Pool D
1	2	3	4
8	7	6	5
9	10	11	12
16	15	14	13

Teams will be seeded into the Championship or Consolation bracket based on their placement in their pool. The top two (2) teams from each pool will go into the championship bracket for day two (2), and the bottom two (2) teams during pool play will go into the consolation bracket for day two (2).

1166.4.1 CHAMPIONSHIP/CONSOLATION BRACKET

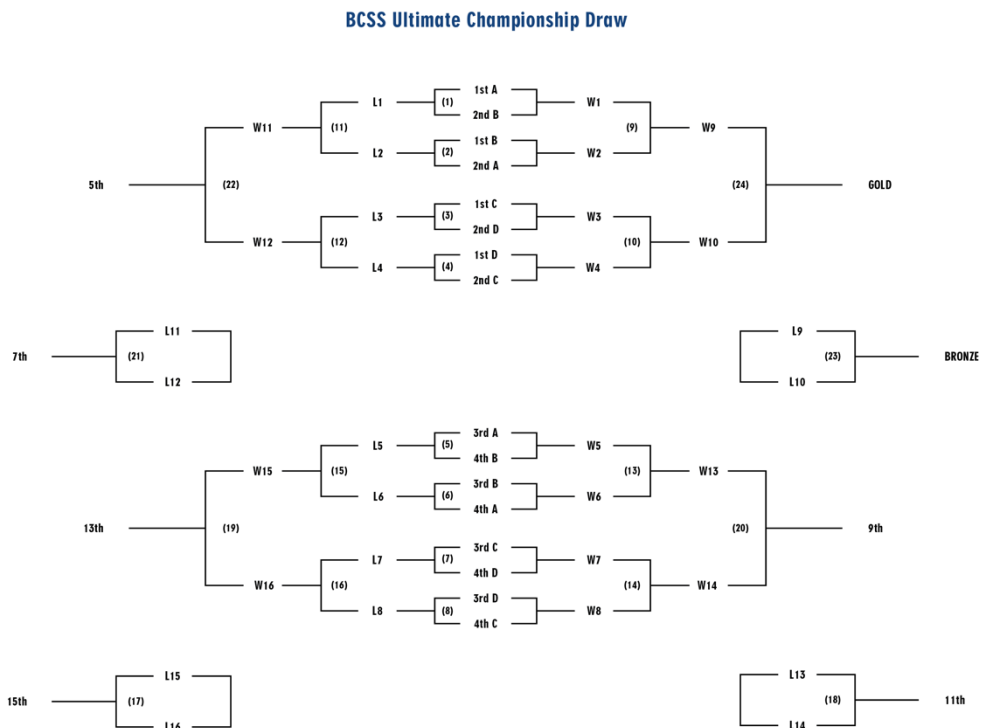

1166.5 TIE BREAKING PROCEDURE

1166.5.1 Two Way Tie

In the case of a tied record between two teams at the conclusion of the round robin; the head to head match up will be used to determine the higher ranking team.

1166.5.2 Three Way Tie:

- In the case of a tie between 3 teams, the record in the games between those teams will be considered.
- If teams are all 1-1 (a circular tie), point differential will be calculated for the games between the 3 tied teams.
- If this results in a tie, then points scored for each team in these games will be used.
- If this results in a tie then the total point difference for the teams in current pool games will be used.
- If this results in a tie then total point difference for all games played in the tournament will be used.
- If this results in a tie then total points scored for each team in all games in the tournament will be used.
- If this results in a tie then, if reasonable, at the sole discretion of the Tournament Director a game to 3 points will be contested between the remaining tied teams. If in the discretion of the Tournament Director, it is unreasonable to do so, a coin will be

flipped to break the remaining tie.

Note: The outcomes of the tie breaker will be used to place all teams. If all teams are placed after the first tie breaker, then those seedings are used. We will not go back to head to head or previous tie-breakers after this process has begun. Remaining ties will be broken by proceeding through the procedure.

1167.0

AWARDS

- AAA BCSS Championship Banner
- AA BCSS Championship Banner
- Gold, Silver and Bronze Medals for the top 3 teams in each tier, 30 medals will be provided for each team. Any additional medals can be purchased by the school through BCSS.
- AAA Spirit of the Game plaque
- AA Spirit of the Game plaque
- Placement photo frames for each team in both tiers.

1170.0 VOLLEYBALL

1171.0

Year	Max number of playing days	First Day of Play	Last Day of Play	Minimum Numbers	Season of Play
2021/22	26	Mon - Week 6	Sat - Week 18	6	Fall
2022/23	26	Mon – Week		6	Fall
2023/24	26	Mon – Week		6	Fall

1172.0 RULES OF PLAY

1172.1 The rules of play governing BCSS Volleyball shall follow those of Volleyball Canada with the following modifications:

1172.1.1 Teams may have as many players as they wish on their roster however teams may dress a maximum of 15 players per match during zone and provincial championships. The 15 dressed players may change from match-to-match.

1172.1.2 All matches will use the 12-sub unlimited rule and a libero.

1172.1.2 A team may designate a different player as the Libero each set. The Libero does not serve.

1172.2.3 Teams are to switch sides after each set. At the conclusion of volleyball matches, or any side change, both teams are free to immediately begin their post-game handshake, or switch sides as in past practice, and do not need to line up on the baseline.

1172.2.4 Dangling jewelry (of any size or shape), watches, rings, and other hand or arm jewelry are to be removed. Pins and studs are advised to be removed.

1172.2.6 GIRLS ONLY: Teams may play the ball off the ceiling (including overhead obstructions) provided that the contact with the ceiling takes place above the floor within the court and free zone and the ball does not cross into the opponents playing space immediately after contacting the ceiling or obstruction

1174.0 EQUIPMENT

1174.1 The official game ball is the Baden VCOR V5S Volleyball

1174.2 Uniform Requirements:

- All players except the Libero must be dressed identically, shorts must closely match.
- Players' jerseys must be numbered 1 - 99.
- The number must be placed on the jersey at the center on the front and on the back.
- The Libero must wear a uniform which has a different dominant colour than that of the team jersey.
- The Libero jersey must clearly contrast with the rest of the team.
- The Libero must have a different number (1-99) from all other players on the team.

1175.0 OFFICIALS

The 1st official (R1) at all Zone and Provincial Championship matches will be a Volleyball Canada certified official. Where possible, the 2nd official (R2) should also be a Volleyball Canada certified official.

1176.0 PROVINCIAL CHAMPIONSHIPS

1176.1 BOYS VOLLEYBALL CHAMPIONSHIPS BERTHING

1176.1.2 'A' and 'AA' Boys Volleyball Championship - Sixteen (16) Team Tournament

1176.1.2.1 Each of the nine (9) BCSS zones will receive one (1) berth;

1176.1.2.1 If the tournament is school based, the tournament host will receive one (1) berth

1176.1.2.1 One (1) berth will be awarded to the two (2) BCSS zones with the highest number of eligible teams

1176.1.2.4 The remaining at-large berths, and any vacant berths will be awarded to the strongest non-qualifying teams, at the discretion of the seeding committee.

The seeding committee will meet to deliberate at-large berths, and tournament seeding immediately after the conclusion of zone championships, approximately 10 days prior to the championship beginning

1176.1.2.5 No zone may have more than three (3) berths, exclusive of the host berth, if applicable

1176.1.3 'AAA' Boys Volleyball Championship - Twenty (20) Team Tournament

1176.1.3.1 Each of the nine (9) BCSS zones will receive a one (1) berth;

1176.1.3.1 If the tournament is school based, the tournament host will receive one (1) berth, no host berth will be awarded for a centrally hosted event

1176.1.3.1 One (1) berth will be awarded to the four (4) BCSS zones with the highest number of eligible teams

1176.1.3.4 The remaining at-large berths, and any vacant berths will be awarded to the strongest non-qualifying teams, at the discretion of the seeding committee.

The seeding committee will meet to deliberate at-large berths, and tournament seeding immediately after the conclusion of zone championships, approximately 10 days prior to the championship beginning

1176.1.2.5 No zone may have more than five (5) berths, exclusive of the host berth, if applicable

1176.2

GIRLS VOLLEYBALL BERTHING

1176.2.1 'A' 'AA' & 'AAA' Girls Volleyball Provincial Championships - Sixteen (16) Team Tournaments

- Each of the nine (9) BCSS zones will receive one berth
- One berth is awarded to the host school, if applicable
- At-large championship berths will awarded to the top non-qualifying teams, at the discretion of the seeding committee.
 - The seeding committee will meet to deliberate at-large berths, and tournament seeding immediately after the conclusion of zone championships, approximately 10 days prior to the championship beginning
- No zone may receive more than five (5) total berths to the championship, exclusive of the host berth
- Vacated Berths – Berths not filled will be awarded by the seeding committee

1176.2.2 'AAAA' Girls Volleyball Provincial Championship- Twenty (20) Teams

- Each of the nine (9) BCSS zones will receive one berth
- One berth is awarded to the host school, if applicable
- At-large championship berths will awarded to the top non-qualifying teams, at the discretion of the seeding committee. (Needs timeline)
- No zone may receive more than five (5) total berths to the championship, exclusive of the host berth
- Vacated Berths – Berths not filled will be added to and awarded as an at-large berth by

the seeding committee if known at or prior to the seeding call. After the call, vacated berths will be filled by a conference including the Sport Advisory Chair or designate, the BCSS Executive Director or designate, and the Tournament Director.

1176.3

TOURNAMENT STRUCTURE

1176.3.2 "A" and "AA" BOYS

- Each tournament will begin with power pools of four (4) teams each, where each team will play a best 2-of-3 match against the each of the other teams in their power pool.
- At the conclusion of the power pool round, teams will enter playoff bracket at the spot of their finish in the power pool, except that the top team in pool will move up one additional spot, and the bottom in each pool, will drop one additional spot. (ie. If you are in the 2nd pool (Seeds 5-8) and finish 8th, the team will enter the playoff bracket in the 9th spot. A team that is in the 9-12 pool, and finishes first, in their pool, will be 8th.)
- All championship matches in the playoff bracket, and the bronze medal match will be best 3-of-5. All consolation matches, will be best 2-of-3.
- Seeding will be determined by the Championship Host Committee in collaboration with the BCSS office and the following seeding structure will be allocated to each of the Pools:

1176.3.2.1 "A" and "AA" BOYS – POWER POOLS

Pool A	Pool B	Pool C	Pool D
1	5	9	13
2	6	10	14
3	7	11	15
4	8	12	16

1176.3.2.2 "A" and "AA" BOYS – CHAMPIONSHIP DRAW

BCSS A & AA Boys Volleyball Championship Draw

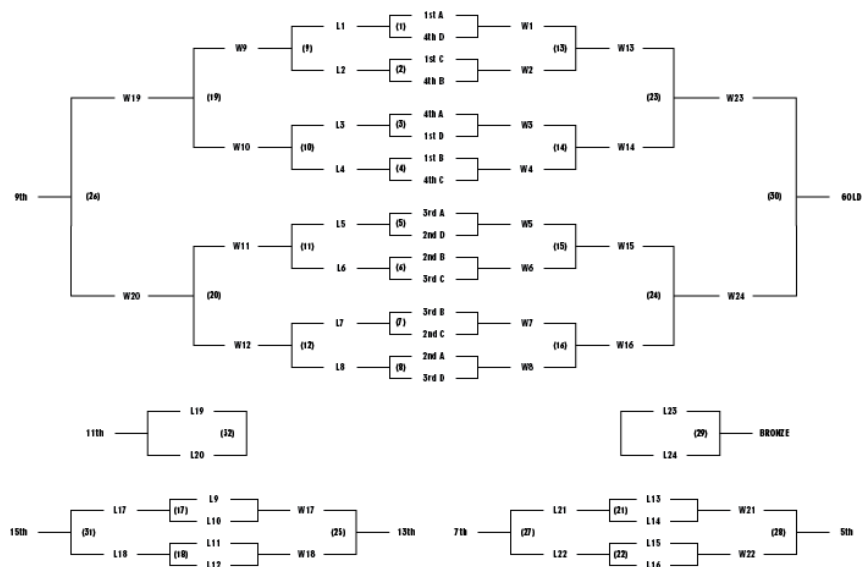

1176.3.2 "AAA" BOYS

- Each tournament will begin with power pools of four (4) teams each, where each team will play a best 2-of-3 match against the each of the other teams in their power pool.
- At the conclusion of the power pool round, teams will enter playoff bracket at the spot of their finish in the power pool, except that the top team in pool will move up one additional spot, and the bottom in each pool, will drop one additional spot. (ie. If you are in the 2nd pool (Seeds 6-10) and finish last (10th), the team will enter the playoff bracket in the 11th spot. A team that is in the 11-15 pool, and finishes first, in their pool, will be 10th.)
- All championship matches in the playoff bracket, and the bronze medal match will be best 3-of-5. All consolation matches, will be best 2-of-3.
- Seeding will be determined by the Championship Host Committee in collaboration with the BCSS office and the following seeding structure will be allocated to each of the Pools:

1176.3.2.1 "AAA" BOYS – POWER POOLS

Pool E	Pool F	Pool G	Pool H	Pool I
1	5	9	13	17
2	6	10	14	18
3	7	11	15	19
4	8	12	16	20

1176.3.2.2 "AAA" BOYS – CHAMPIONSHIP DRAW

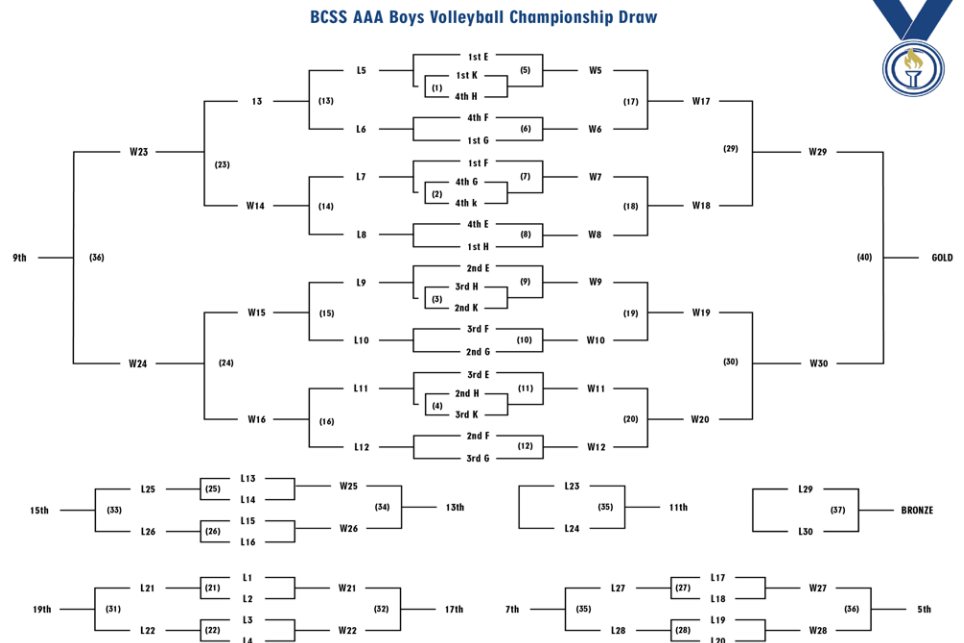

1176.3.4 "A" GIRLS

- Each tournament will begin with power pools of four (4) teams each, where each team will play a best 2-of-3 match against the each of the other teams in their power pool.
- At the conclusion of the power pool round, teams will enter playoff bracket at the spot of their finish in the power pool, except that the top team in pool will move up one additional spot, and the bottom in each pool, will drop one additional spot. (ie. If you are in the 2nd pool (Seeds 5-8) and finish 8th, the team will enter the playoff bracket in the 9th spot. A team that is in the 9-12 pool, and finishes first, in their pool, will be 8th.)
- All championship matches in the playoff bracket, and the bronze medal match will be best 3-of-5. All consolation matches, including the bronze medal match will be best 2-of-3.
- Seeding will be determined by the Championship Host Committee in collaboration with the BCSS office and the following seeding structure will be allocated to each of the Pools:

Seeding will be determined by the Championship Host Committee in collaboration with the BCSS office and the following seeding structure will be allocated to each of the Pools:

1176.4.4 "A" GIRLS – POWER POOLS

Pool A	Pool B	Pool C	Pool D
1	5	9	13
2	6	10	14
3	7	11	15
4	8	12	16

1176.4.4 "A" GIRLS – CHAMPIONSHIP DRAW

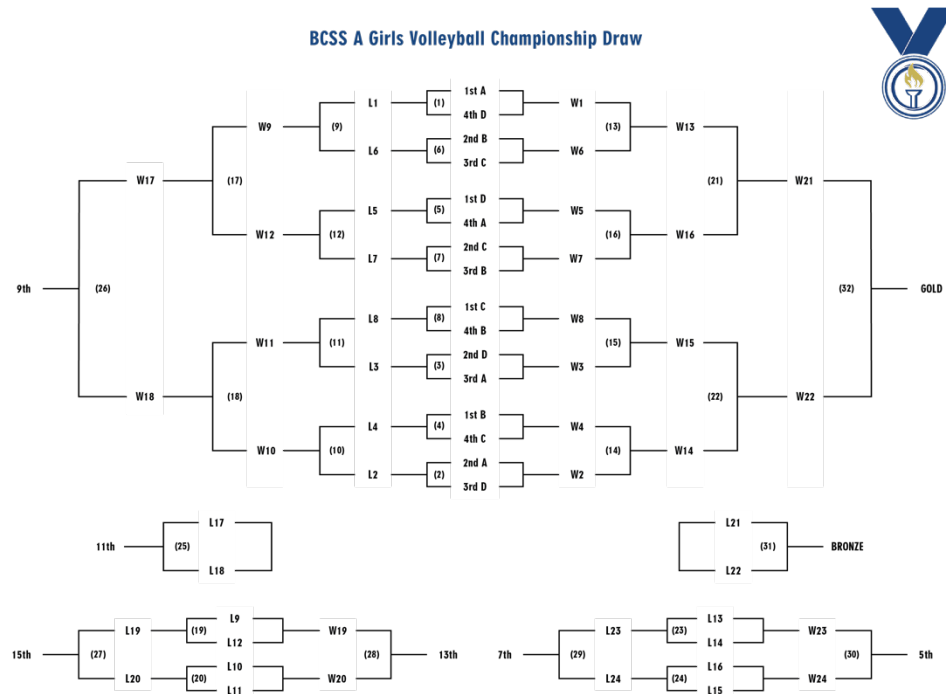

1176.35 "AA" GIRLS

The BCSS AA Girls Volleyball Provincial Championship will have teams competing in round robin pool play in a best two (2) of three (3) series. All championship playoff matches will be a best three (3) of five (5) series. All consolation matches will continue a best two (2) of three (3) series.

Seeding will be determined by the Championship Host Committee in collaboration with the BCSS office and the following seeding structure will be allocated to each of the Pools:

1176.4.5 "AA" GIRLS – TOURNAMENT POOLS

Pool A	Pool B	Pool C	Pool D
1	2	3	4
7	8	5	6
11	12	9	10
13	14	15	16

1176.4.6 "AA" GIRLS – CHAMPIONSHIP DRAW

BCSS AA Girls Volleyball Championship Draw

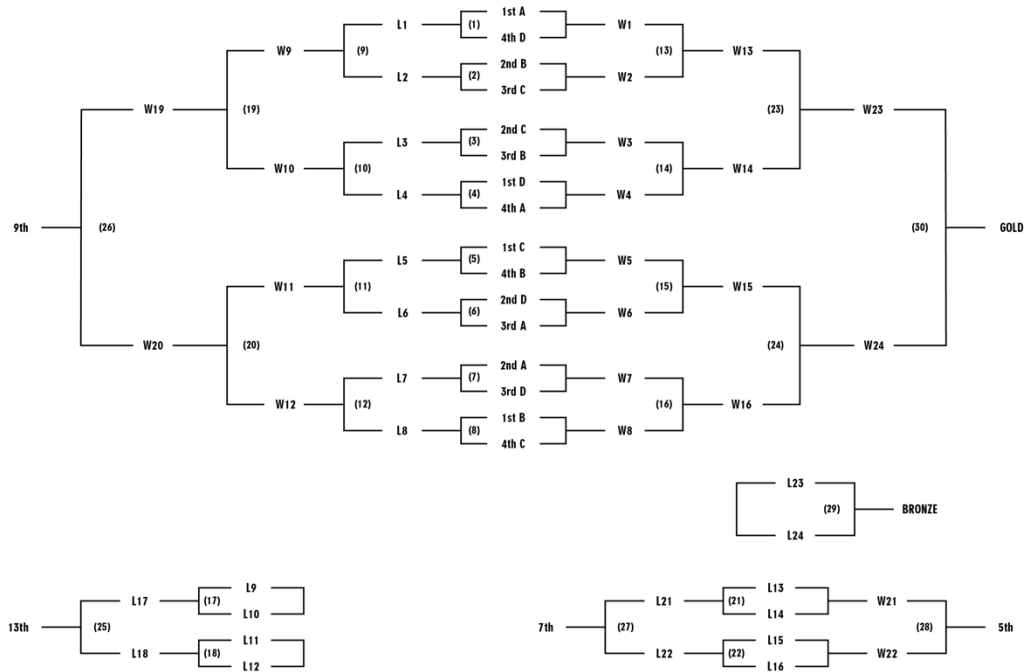

1176.3.6 "AAA" GIRLS

The BCSS AAA Girls Volleyball Provincial Championship will have teams competing in round robin pool play in a best two (2) of three (3) series. All championship playoff matches will be a best three (3) of five (5) series. All consolation matches will continue a best two (2) of three (3) series.

Seeding will be determined by the Championship Host Committee in collaboration with the BCSS office and the following seeding structure will be allocated to each of the Pools:

1176.4.6 "AAA" GIRLS – TOURNAMENT POOLS

Pool A	Pool B	Pool C	Pool D
1	2	3	4
7	8	5	6
11	12	9	10
13	14	15	16

1176.4.7 "AAA" GIRLS – CHAMPIONSHIP DRAW

BCSS AAA Girls Volleyball Championship Draw

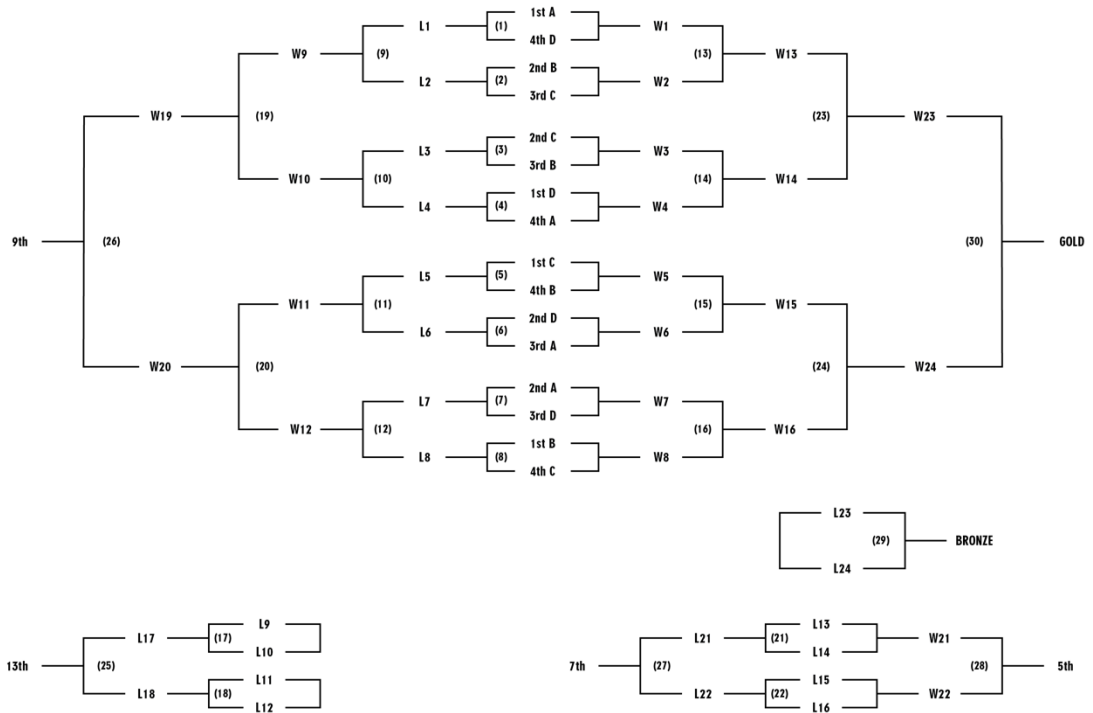

- Trophies for top 6 teams
- Most Sportsmanlike Team
- 1st team all-star team (6)
- 2nd team all-star team (6)
- Most outstanding Player

1077.0 **CHAMPIONSHIP FACILITY HOSTING REQUIREMENTS**

The host is required to have access to a minimum of four (4) regulation size volleyball courts. These courts do not need to be on a single site but must be relative in proximity to one another. Any court for use in a zone or provincial championship, must be rectangular in shape, and a minimum of 18m in length, 2m for serving space and 9m in width.

1180.0 WRESTLING

** These rules are included as a placeholder in the 2021-2022 handbook, over the summer rules will be finalized by the BCSS office and brought to a vote by the Legislative Assembly at the Fall Planning Meeting in October.**

Year	Number of Contest Dates	First Day of Play	Last Day of Play	Minimum Numbers	Season of Play
2021/22	26	Week 18	Week 30	1	Winter
2022/23	26			1	Winter
2023/24	26			1	Winter

1181.0

1182.0 RULES

The rules governing Wrestling shall be those of the Wrestling Canada Lutte (WCL) Cadet Rules with the following modifications;

- 1183.1 **Weight Classes-** All weight classes must be used for BCSS provincial and zone championships
- MALES: 38, 41, 45, 48, 51, 54, 57, 60, 63, 66, 70, 74, 78, 84, 90, 110, 110+kg (130kg maximum)
 - FEMALES: (34kg minimum) 40, 43, 47, 51, 54, 57, 60, 64, 69, 75, 90, 90+kg (110kg maximum)
- 1183.2 **Weighing- IN-** Provincial Championships will have a weigh-in on the day before the competition usually between 4 – 8 pm. The duration of the weigh-in period is two hours (e.g. 4 – 6 pm) integrated with the medical control. Each wrestler is allowed ONE hour to weigh-in, which starts after their first official weigh in. If a wrestler does not make weight on the first attempt, the referee will record the time of day on the weigh in sheet. A wrestler not making weight on the first try is given 1 hour or till the end of the scheduled weigh in period whichever expires first. There will be separate weigh – in for males and females, which should occur at the same time if possible. (Depends on # entries / # scales / # volunteers)
- 1183.3 **The Mat-** Certain high school leagues allow a 6 meter to 8 meter central wrestling area for their competitions. This size of mat is not used for BCSSWA Provincial Championships (8 Meters Minimum).
- 1183.4 **Doping –** Doping Control, with sampling both at competitions and during training periods, may be conducted on all participants in BCSSWA/ BCSS/ BCWA sanctioned events or programs. Failure to provide a sample when requested to do so, constitutes a positive doping infraction
- 1183.5 **Call for Competitors-** All competitors are required to arrive at the edge of the mat immediately upon being called;
- Competitors will be allowed 3 minutes after being called to arrive at the mat and identify themselves to the officiating team. Three calls shall be given at 1 minute intervals during this time.
 - If after the expiration of the above time period the athlete has not reported to the officiating team, then the athlete shall lose the match by disqualification, but is allowed to continue in the competition.
- 1183.6 **Interruption Due to Injury-**The entire suspension may be accorded at one time or accumulated at various times throughout the bout. In BCSSWA matches when a wrestler is injured and requires attention from the First Aid Attendant, the injury time begins will not start until available medical attendant arrives at the mat.
- 1183.7 **The Coach**
- The coach must remain seated in the appropriate corner at the edge of the mat during the bout except during the 30-second break between rounds. The coach may leave their seat to tend to an injured or bleeding athlete on the wrestling mat. The Mat Chairperson may ask the coach to approach the chair to obtain or provide specific clarification.
 - The coach may encourage the wrestler and give instructions; however, the coach will not indicate points with hands nor attempt to influence the referee’s judgement by shouting phrases or using signals utilized by officials.
 - The coach is not allowed to speak to the referee, judge or the other athlete or coach during the match. The coach sitting in the athlete’s corner during the match may however, request an explanation from the mat chairperson, regarding a specific call, at an appropriate break in the action. If the mat chairperson calls a conference, the coaches shall refrain from approaching the table or attempting to influence the

outcome of the conference.

1183.8 **Passivity** - If no scoring occurs during the 30-second activity period, the bout will NOT be Stopped and the referee award and announce the 1 point to the wrestler not on the 30 – second activity clock. Wrestling will continue uninterrupted.

1183.9 **Illegal and Potentially Dangerous Holds**

- NO BACK SUPPLAYS; Definition; back bending throw cannot be initiated whilst the offensive wrestler has their chest on the opponent’s back.
- NO FRONT SALTOS: Definition; Back bending throw from the front cannot be initiated whilst the offensive wrestler has their opponent’ arms trapped in the double – whizzer position. (Double over hook)

1184.0 EQUIPMENT

Singlet: A one-piece singlet of the colour assigned to them (red or blue). School colour singlet’s (60% of primary(main) school colour) will be allowed at BCSSWA Zone and Championships , provided that the wrestler provides the proper red or blue coloured ankle strap corresponding to the assigned colour on the match bout sheet. No Club affiliated singlets are to be worn during the entire High School season, from December 1st to the B.C. High School Championships. Referees are to be instructed to have any offending athlete change within three minutes into another (red, blue, or school) singlet or a pair of shorts and T-Shirt.

1185.0 OFFICIALS

All BCSS Wrestling competitions will be officiated by certified BC Wrestling officials

1186.0 PROVINCIAL COMPETITION

1186.1 **BERTHING**

Qualification for the BCSS Provincial Wrestling tournament will happen at the zone level.
Teams who win their Zone Championship

1186.2 **STRUCTURE**

- At the BCSSWA Championships, the team points awarded in each weight class shall be proportional to the number of participants in each weight class and shall be weighted in the following manner.

# of competitors	6+	5	4	3	2	1
1st	16	12	9	6	3	1
2nd	12	9	6	3	1	
3rd	9	6	3	1		
4th	6	3	1			
5th	3	1				
6th	1					

- All the top placing wrestlers from each school in a given weight class will be awarded team classification points.
- Any weight class involving boys or girls, that has fewer than six participants in the BCSSW Championships or Zone Qualification tournaments, will not have team points calculated from the top of the team point scale. Instead team points would be counted from the bottom of the scale if there are fewer than six participants. AS per above chart

1186.3

SEEDING

The BCSS Wrestling Seeding Committee will be responsible for seeding the provincial championship based on the current season and zone championship results. Seeding will be released the Wednesday prior to the Provincial Championship. Any BCSS Wrestling Coach may submit a Seeding Appeal Application to the Seeding Committee for consideration, appeal applications will be due no later than the Friday before the Provincial Championship. The Seeding Committee will evaluate the Seeding Appeal Applications and release the finalized seeding for the Provincial Championship after the Final Seeding Confirmation Meeting which will take place the Saturday before the Provincial Championship.

1186.3.1 The Seeding Committee will use the following seeding criteria when establishing the seeding for the BCSS Wrestling Provincial Championship.

- Head to Head matches: must be from official matches refereed by sanctioned officials and only matches from the current BCSS season
- Previous years BCSS Wrestling Provincial Championship Results
- Other tournament results from the current season will be considered if necessary.
- If a consensus is not reached, then a majority vote by the Zone Reps will decide seeding.
- The four top wrestlers in both boys and girls weight classes will be seeded if possible.

1186.4

DRAW

1086.5

TIE BREAKING PROCEDURE

All matches will have mat size video review. The current WCL Challenge process procedure will be used throughout the BCSS Wrestling Championship. If a challenge is lost no point will be awarded to the opponent.

1086.6

WEIGH IN PROCEDURE

- Athletes require their Weigh in card & Accreditation pass to weigh in.
- Medical personnel will examine each competitor for any disqualifying medical conditions such as ringworm, staph, or herpes. Before weighing in, athletes must undergo a medical examination. Wrestlers then proceed to the scale area.
- Do not leave clothes or valuables lying around. Carry all belongings to the scale and place them in the basket before stepping on the scales.
- Males and females must weigh-in wearing their competition singlet. Wrestlers will not be accepted at weigh-in altered singlets or dressed only in undergarments.
- Fingernails must be cut short and facial hair removed (or full growth) prior to weigh-in.
- Once a wrestler has made weight, make sure the official signs your name off the list, then pick up your belongings and exit the scale area.
- If an athlete does not make weight on their first attempt, they have one hour, make weight. Athletes must keep their weigh-in card until they make weight.
- Remember that the use of sauna suits or garbage bags is strictly prohibited. Athletes using these artificial weight loss techniques will be disqualified from the tournament.
- There is a .2 kg weight allowance for the BCSSWA Championships. A wrestler cannot compete in any weight class other than the one they have qualified for.
- In Heaviest Weight classes athletes must weight at least the minimum weight:
- Boys 110Kg, Girls 90 KG

- There is only a one day weigh-in.

1187.0

AWARDS

- A BCSS Championship Banner will be awarded to the Top Girls team, Top Boys Team, and Top Combined
- Awards for 4th-6th place in each weight class in each category (Boys/Girls)
- Team awards for top 10 teams in each category (Boys/Girls)
- Team awards for Top 3 teams aggregate division
- Most Outstanding Male and Female Wrestler Awards (Jostens Rings)
- Best Finals Matches (Boys/Girls)

APPENDIX I: 52 WEEK CALENDAR

WEEK NUMBERS (STANDARDIZED)					
	2021-22	2022-23	2023-24	2024-25	2025-26
	combined	combined	combined	combined	combined
1	8/2-8/8	8/1-8/7	8/7-8/13	8/5-8/11	8/4-8/10
2	8/9-8/15	8/8-8/14	8/14-8/20	8/12-8/18	8/11-8/17
3	8/16-8/22	8/15-8/21	8/21-8/27	8/19-8/25	8/18-8/24
4	8/23-8/29	8/22-8/28	8/28-9/3	8/26-9/1	8/25-8/31
5	8/30-9/5	8/29-9/4	9/4-9/10	9/2-9/8	9/1-9/7
6	9/6-9/12	9/5-9/11	9/11-9/17	9/9-9/15	9/8-9/14
7	9/13-9/19	9/12-9/18	9/18-9/24	9/16-9/22	9/15-9/21
8	9/20-9/26	9/19-9/25	9/25-10/1	9/23-9/29	9/22-9/28
9	9/27-10/3	9/26-10/2	10/2-10/8	9/30-10/6	9/29-10/5
10	10/4-10/10	10/3-10/9	10/9-10/15	10/7-10/13	10/6-10/12
11	10/11-10/17	10/10-10/16	10/16-10/22	10/14-10/20	10/13-10/19
12	10/18-10/24	10/17-10/23	10/23-10/29	10/21-10/27	10/20-10/26
13	10/25-10/31	10/24-10/30	10/30-11/5	10/28-11/3	10/27-11/2
14	11/1-11/7	10/31-11/6	11/6-11/12	11/4-11/10	11/3-11/9
15	11/8-11/14	11/7-11/13	11/13-11/19	11/11-11/17	11/10-11/16
16	11/15-11/21	11/14-11/20	11/20-11/26	11/18-11/24	11/17-11/23
17	11/22-11/28	11/21-11/27	11/27-12/3	11/25-12/1	11/24-11/30
18	11/29-12/5	11/28-12/4	12/4-12/10	12/2-12/8	12/1-12/7
19	12/6-12/12	12/5-12/11	12/11-12/17	12/9-12/15	12/8-12/14
20	12/13-12/19	12/12-12/18	12/18-12/24	12/16-12/22	12/15-12/21
21	12/20-12/26	12/19-12/25	12/25-12/31	12/23-12/29	12/22-12/28
22	12/27-1/2	12/26-1/1	1/1-1/7	12/30-1/5	12/29-1/4
23	1/3-1/9	1/2-1/8	1/8-1/14	1/6-1/12	1/5-1/11
24	1/10-1/16	1/9-1/15	1/15-1/21	1/13-1/19	1/12-1/18
25	1/17-1/23	1/16-1/22	1/22-1/28	1/20-1/26	1/19-1/25
26	1/24-1/30	1/23-1/29	1/29-2/4	1/27-2/2	1/26-2/1
27	1/31-2/6	1/30-2/5	2/5-2/11	2/3-2/9	2/2-2/8
28	2/7-2/13	2/6-2/12	2/12-2/18	2/10-2/16	2/9-2/15
29	2/14-2/20	2/13-2/19	2/19-2/25	2/17-2/23	2/16-2/22
30	2/21-2/27	2/20-2/26	2/26-3/3	2/24-3/2	2/23-3/1
31	2/28-3/6	2/27-3/5	3/4-3/10	3/3-3/9	3/2-3/8
32	3/7-3/13	3/6-3/12	3/11-3/17	3/10-3/16	3/9-3/15
33	3/14-3/20	3/13-3/19	3/18-3/24	3/17-3/23	3/16-3/22
34	3/21-3/27	3/20-3/26	3/25-3/31	3/24-3/30	3/23-3/29
35	3/28-4/3	3/27-4/2	4/1-4/7	3/31-4/6	3/30-4/5
36	4/4-4/10	4/3-4/9	4/8-4/14	4/7-4/13	4/6-4/12
37	4/11-4/17	4/10-4/16	4/15-4/21	4/14-4/20	4/13-4/19
38	4/18-4/24	4/17-4/23	4/22-4/28	4/21-4/27	4/20-4/26

39	4/25-5/1	4/24-4/30	4/29-5/5	4/28-5/4	4/27-5/3
40	5/2-5/8	5/1-5/7	5/6-5/12	5/5-5/11	5/4-5/10
41	5/9-5/15	5/8-5/14	5/13-5/19	5/12-5/18	5/11-5/17
42	5/16-5/22	5/15-5/21	5/20-5/26	5/19-5/25	5/18-5/24
43	5/23-5/29	5/22-5/28	5/27-6/2	5/26-6/1	5/25-5/31
44	5/30-6/5	5/29-6/4	6/3-6/9	6/2-6/8	6/1-6/7
45	6/6-6/12	6/5-6/11	6/10-6/16	6/9-6/15	6/8-6/14
46	6/13-6/19	6/12-6/18	6/17-6/23	6/16-6/22	6/15-6/21
47	6/20-6/26	6/19-6/25	6/24-6/30	6/23-6/29	6/22-6/28
48	6/27-7/3	6/26-7/2	7/1-7/7	6/30-7/6	6/29-7/5
49	7/4-7/10	7/3-7/9	7/8-7/14	7/7-7/13	7/6-7/12
50	7/11-7/17	7/10-7/16	7/15-7/21	7/14-7/20	7/13-7/19
51	7/18-7/24	7/17-7/23	7/22-7/28	7/21-7/27	7/20-7/26
52	7/25-7/31	7/24-7/30	7/29-8/4	7/28-8/3	7/27-8/2
53	-	7/31-8/6	-	-	-